

BEFORE THE ILLINOIS POLLUTION CONTROL BOARD

IN THE MATTER OF: )  
 )  
WATER QUALITY STANDARDS AND )  
EFFLUENT LIMITATIONS FOR THE ) R08-9  
CHICAGO AREA WATERWAY SYSTEM ) (Rulemaking - Water)  
AND THE LOWER DES PLAINES RIVER: )  
PROPOSED AMENDMENTS TO 35 Ill. )  
Adm. Code Parts 301, 302, 303 and 304 )

**PRE-FILED TESTIMONY OF SAMUEL DOREVITCH**

My name is Samuel Dorevitch and I am an environmental health researcher at the University of Illinois at Chicago School of Public Health. I am a medical doctor, with training and board certification in Emergency Medicine and also in Preventive Medicine, with specialization in Occupational Medicine. Over the last six years, I've conducted research on local environmental health issues, such as the effects of public housing demolition and the reconstruction of the Dan Ryan expressway on air quality. In addition to being a scientist, I have been an advocate for reducing pollution and improving the environment. Over the years, I have testified at U.S. EPA hearings in favor of setting more stringent regulatory standards for ozone, particulate matter air pollution, and off-road diesel emissions. I have also spoken out in the media about the impact of coal-fired power plants on local air quality. I have added my name to the National Resources Defense Council's list of those opposed to the U.S. EPA's recent effort to stop regulating lead as an air pollutant.

I have advocated for tighter regulations in the above contexts because there is an overwhelming body of public health research that demonstrates negative consequences of air pollution. For ozone, particulate matter, lead and other air pollutants, a solid scientific foundation exists for setting a regulatory standard. Just as I support improvements in air quality as a means of promoting public health, I recognize the critical role that improvements in drinking

water quality have played in promoting the health of the public. The scientific basis for improving air quality and drinking water quality are well-established, strong, and based on thousands of scientific studies. However, in the case of water recreation, and limited contact recreation in particular, we are just beginning to develop the scientific data that will help define what regulatory measures are appropriate for protecting the health of public.

In contrast with the thousands of scientific papers that have addressed the health effects of air pollution, less than 20 observational epidemiologic studies of primary contact recreation in the US have been published. For limited contact recreation, no studies have been done in the US, less than 5 have been done in Europe, and those looked primarily at whitewater canoeing, an activity that does not take place on the Chicago Area Waterway System, or CAWS. No research has ever characterized the health risks of activities observed on the CAWS, namely boating, paddling, rowing and fishing. We do not know if people who engage in limited contact recreational activities develop illnesses, such as gastroenteritis or eye infections or skin infections or respiratory problems at higher risk than the general population.

Because the scientific literature does not provide guidance for establishing health-based regulations for CAWS recreation, one would want to know the following in developing efforts to improve water quality on the CAWS:

- Are rates of illness higher among CAWS recreators compared to recreators doing the same activities on waters that do not receive treated wastewater?
- If so, how frequently do such cases of illnesses occur above background rates?
- Are the pathogens responsible for illness bacteria, viruses or parasites, which may require different water quality treatment strategies?

- Are people who engage in specific recreational activities at increased risk while those who engage in other activities are not?
- Are there differences in risk on different CAWS reaches?
- How does the contribution of water reclamation plants to microbial measures of water quality compare to the contributions of runoff and sewer overflows?
- If the Pollution Control Board were to establish a disinfection requirement rather than a microbial water quality standard, how would risk to the public be determined along various CAWS reaches?
- Following rainfall and other events that are unrelated to wastewater treatment, what microbes should be measured in the water to evaluate and communicate risk to the public?
- If the Pollution Control Board were to establish a water quality standard, rather than a disinfection requirement, is there a microbial water quality level above which risk is unacceptable and below which risk is acceptable?

If there were known outbreaks of disease linked to CAWS recreation, I would suggest public health action now, rather than research. However, I am not aware of epidemics attributed to CAWS recreation. Since 1978, the U.S. Centers for Disease Control and Prevention has monitored disease outbreaks linked to water recreation. Using “WBD OSS,” the Waterborne Disease Outbreak Surveillance System, the CDC compiles information about outbreaks due to treated and untreated recreational waters. Hundreds of outbreaks and thousands of cases of illness have been identified, described, and in varying degrees, investigated over the years. Outbreaks from Illinois – including a recent outbreak of *Cryptosporidiosis* in Tazewell County – have been reported. To the best of my knowledge, local health departments, the Illinois

Department of Public Health, and the CDC have not identified outbreaks of disease attributed to CAWS recreation.

This does not mean that people haven't gotten sick after using the CAWS. It is possible that such cases fly beneath the radar of the public health monitoring system. That is why it is important to identify such cases, to determine the microbes responsible for illness, to evaluate the locations where water contact took place, to characterize the water quality at that location, and to estimate the frequency with which such illness occurs. The fact that outbreaks linked to CAWS recreation have not been identified does suggest that we have the opportunity to define the scope and specifics of the problem before developing a potential solution. This lack of known outbreaks of disease is consistent with the finding of the recent quantitative microbial risk assessment. That study used hundreds of measurements of water quality on the CAWS and estimated that rates of illness among limited contact recreators are about 1-2 cases per 1,000 uses.

Although risk assessment can be very useful in comparing various risk scenarios, such analyses do not involve direct measurement of risk in populations. That type of research – the study of the distribution and determinants of states of health and disease in population – is epidemiology. Because epidemiologic studies involve the direct measurement, rather than the statistical modeling of risk, they are of great importance in developing plans to protect the health of the public. I am directing the epidemiologic study of CAWS recreation known as CHEERS, which stands for the Chicago Health, Environmental Exposure, and Recreation Study. This is the first epidemiologic study of the health risks of fishing, boating, rowing and paddling. This research uses the gold standard of observational epidemiologic studies, the prospective cohort design, and has been developed by a multi-disciplinary team of experienced researchers, with

backgrounds in infectious disease medicine, environmental medicine, epidemiology, biostatistics, industrial hygiene and environmental science. A panel of recognized leaders in the fields of water microbiology and health from the U.S. Centers for Disease Control and Prevention, the U.S. Environmental Protection Agency, and other universities has reviewed and endorsed the design and protocols of the research, and continues to monitor the quality of data collected. A copy of the review panel's endorsement has been submitted by Mr. Daniel Woltering of the Water Environment Research Foundation and is Public Comment Number 63 in the docket for this rulemaking.

I would like to give you a broad brushstroke view of the CHEERS research. A copy of the epidemiologic study protocol has been submitted as an attachment to my written testimony for anyone who wishes to see the details of this research. We recruit people into one of three study groups. The CAWS Group is composed of people who row, paddle, fish or go boating on the CAWS. The General Use Waters Group consists of people who do these same activities on a number of area lakes, rivers and lagoons not including the CAWS. The Unexposed Group includes people who do outdoor activities that do not involve water (such as jogging or biking) at about the same time and about the same place as the recruitment of participants into the other two groups. Individuals in all three groups undergo interviews on the day of recreation, and then are contacted for three telephone interviews over the following three weeks. All interviews are conducted using computer assisted methods, which ensure that participants are asked the same questions in a neutral fashion. Field interviews address current health, and for those who engage in water recreation, the extent of their contact with the water. Telephone interviews address changes in health status and additional water exposure since recruitment. While the participants are on the water, samples of water are collected and sent for analyses of bacteria,

viruses and parasites. If a participant develops illness, clinical specimens are collected so that the pathogen responsible for illness may be identified. The study uses state-of-the-art methods, which in several respects, surpass the U.S. EPA's ongoing research about primary contact recreation known as the National Epidemiological and Environmental Assessment of Recreational Water (NEEAR) study.

Additionally, a module of CHEERS known as the exposure study seeks to answer important questions regarding water contact among recreators. Rowers, paddlers, boaters and fishers may be exposed to water microbes via several routes: ingestion, inhalation, and skin contact. Ingestion may result from getting water on ones hands and then touching ones mouth, it could result from a splash to the mouth, or it could occur in the unlikely event of capsizing or falling into the water. The exposure study will allow us to describe for the first time how much water exposure occurs by each route for specific recreational activities. These results may be useful in establishing whether some activities pose lower levels of risk (due to lower exposure) than others. We will also have the opportunity to evaluate the assumptions of risk assessments regarding exposure, dose, and risk. Preliminary analyses of 2007 data show that assumptions regarding the duration of various recreational activities were quite accurate. The conduct of an epidemiologic and a risk assessment in tandem is unusual and this opportunity to evaluate the strengths and limitations of risk assessment methods is one reason that there is considerable national interest in applying the final results of this research to the development of water quality regulation.

Epidemiologic studies provide an opportunity to directly measure, rather than model, risk. For this reason the U.S. EPA places considerable weight on epidemiologic studies when establishing environmental standards. A well-designed epidemiologic study seeks to minimize

the possibility that the research will fail to identify a real risk that may exist (a “false negative result”) and to minimize the possibility that a risk will be identified when none exists (a “false positive result”). Early in the development of CHEERS, the research team evaluated numerous approaches for minimizing the possibility of a false positive or a false negative result. In calculating our necessary number of study participants, we used typical values of a 1 in 20 chance of a false positive result and a 1 in 5 chance of a false negative result. We made numerous conservative assumptions in that sample size calculation, and it is becoming apparent that we will have more statistical power than originally anticipated because the rate of drop out by study participants is less than a third of the 15% we had projected. Thus, the chances of failing to identify a real risk are likely less than one in five.

We calculated that a total of 9,330 people should be enrolled in the three recreational categories (i.e. approximately 3,110 people per recreational category as described above). Last summer and fall – the first year of the study – over the first 800 participants signed up for the study. CHEERS has been scaled up substantially this summer, and for the months of May, June and July, an average of more than 1,000 participants were enrolled per month. A breakdown of recruitment by group, by month is included as an appendix to this testimony. By the date of this hearing, we project that 5,500 participants will have been enrolled in CHEERS. We collected data about use of the CAWS, for specific activities at specific locations. A summary of the findings of CAWS recreational use survey in 2007 has been submitted as an appendix to this testimony. Highlights of that summary include the observation that the dominant uses on the North Branch and North Shore Channel are rowing and paddling while the dominant use on the Cal-Sag Channel is motor boating. Fishing from shore is relatively uncommon, and jet skiing is rarer still. Swimming and water skiing were never observed. Data obtained from field

interviews of study participants demonstrates that several dozen individuals on rowing team each use the CAWS more 100 times per year. Similarly, some boaters at the Worth and Alsip launches use the Cal-Sag Channel dozens of times per season. Thus, a small number of users account for a large proportion of uses. These observations add detail to the picture sketched out by the assessment of current uses reported in the UAA. Inconsistencies between our observations and those of the UAA regarding the frequency of specific recreational activities and the distinction between uses and users are likely due to difference in methodologies.

Over 5,000 water samples have been analyzed and more than 150 stool samples have been obtained for analysis by the UIC laboratory and the Illinois Department of Public Health. We are well on our way to completing data collection and moving on to data analyses. The results of those analyses will provide answers to the critical questions about risk, the determinants of risk, exposure, sources of microbes, and causes of illness. The final report will serve as the basis for establishing standards to protect limited contact uses. Preliminary analysis of the 2007 data identifies no difference in rates of gastrointestinal symptoms among recreators in the three study groups. Because that analysis involved less than 10% of the total number of participants who will have been enrolled at the completion of this research, firm conclusions are premature. However, consistent with the lack of reports by public health departments of outbreaks of disease linked to CAWS recreation, our preliminary observations suggest no danger to the health of the population of limited contact recreators on the CAWS.

I favor strong, science-based environmental regulation as a means of protecting public health. Reducing the potential risks of limited contact recreation on the CAWS is an important and complex public health goal. From a policy perspective, one would want to know what the benefits and risks are of current wastewater management and recreation practices, and what the



benefits and risks are of various alternative approaches. The UIC School of Public Health research team is well on the way to defining the risks that limited contact recreators face under current wastewater management practices. I believe that this research should be the basis for sound, science-based environmental policy.

Respectfully submitted,

A handwritten signature in black ink, appearing to read 'SD', with a long, sweeping horizontal line extending to the right.

By: Samuel Dorevitch, MD, MPH  
University of Illinois at Chicago  
School of Public Health

## **Testimony Attachments**

- 1. Curriculum vitae**
- 2. Recruitment by month, by group**
- 3. Use survey summary**
- 4. CHEERS Protocol (Quality Assurance Project Plan documents)**

# CURRICULUM VITAE

**Samuel Dorevitch, M.D., M.P.H.**

University of Illinois at Chicago - School of Public Health  
Division of Epidemiology and Biostatistics  
Division of Environmental and Occupational Health Science  
1603 W. Taylor, M/C 923  
(312) 355-3629  
sdorevit@uic.edu

## **Education and Training**

July 1999-June 2001 Resident, Occupational Medicine, UIC Medical Center  
Aug 1999-May 2001 Environmental and Occupational Health Sciences, UIC School of  
Public Health; Degree awarded: Masters in Public Health  
July 1990-June 1993 Resident, Emergency Medicine, Cook County Hospital  
July 1989-June 1990 Intern, Internal Medicine, Northwestern University-Evanston Hospital  
Sept 1985-June 1989 University of Chicago, Pritzker School of Medicine;  
Degree Awarded: MD  
Sept 1981-June 1985 University of Illinois at Chicago  
Degrees awarded: B.S. with honors, Biological Sciences, B.A.,  
Psychology, with honors

## **Employment**

- 2001-present     Assistant Professor, Research, Division of Environmental and Occupational Health Sciences, University of Illinois at Chicago  
Assistant Professor, Research, Division of Epidemiology and Biostatistics, School of Public Health, University of Illinois at Chicago  
Faculty Occupational Medicine Residency Program
- 2007-present     Clinical Physician, Department of Emergency Medicine, UIC O'Hare Clinic, University of Illinois at Chicago Medical Center
- 1995-present     Staff physician, Emergency Medicine and Occupational Health Services, Lake Forest Hospital, Lake Forest, IL
- 1993-2002        Clinical Instructor, Emergency Medicine, Cook County Hospital, Chicago, Illinois
- 1993-1995        Emergency Medicine and Occupational Medicine, Westlake Community Hospital, Melrose Park, Illinois

## **Academic Honors**

Edmund C. James Scholar, University of Illinois, Chicago, 1983-1985

Phi Beta Kappa

Chief Resident, Emergency Medicine, Cook County Hospital, Chicago, IL, 1992-1993

NIOSH Trainee in Occupational and Environmental Medicine, 1999-2001

Central States Occupational Medicine Association, Scientific Session 2000. Award for presentation by a resident.

## **Publications** (\*refereed journal)

1. Westfall MD, Price KR, Lambert M, Himmelman R, Kacey D, DOREVITCH S, Mathews J. "Intravenous access in the critically injured trauma patient: a multicentered, prospective randomized trial of saphenous cutdown and percutaneous femoral access." Annals of Emergency Medicine, 23:541-545, 1994.\*
2. DOREVITCH S, Forst L. "Occupational hazards of emergency physicians" American Journal of Emergency Medicine, 18:300-311, 2000\*
3. DOREVITCH S, Marder D. "Occupational hazards of municipal solid waste workers". State of the Art Reviews in Occupational Medicine, 16:125-133, 2001.
4. DOREVITCH S, Babbin A. "Ceramics: Hazards, health effects, and prevention". State of the Art Reviews in Occupational Medicine, Oct-Dec;16(4):563-75.2001.
5. Geller RJ, DOREVITCH S, Gummin DD. "Air and Water Pollution" in Toxicology Secrets, Ling LJ, Clark RF, Erickson TB and Trestrail JH (Eds). Hanley & Belfus, Philadelphia, PA. 2001.
6. DOREVITCH S, Forst L, Conroy L, Levy P. "Toxic inhalation fatalities of US construction workers, 1990-1999." Journal of Occupational and Environmental Medicine, 44(7):657-62, 2002.\*
7. Krantz A, DOREVITCH S. "Metal Exposures and Common Chronic Diseases: A Guide for the Clinician". Disease-a-Month,50(5):220-62, 2004.
8. DOREVITCH S, Demirtas H, Persky VW, Erdal S, Conroy L, Schoonover T, Scheff P: "Demolition of high-rise public housing increases particulate matter air pollution in communities of high-risk asthmatics." J Air Waste Management Assoc. 2006 Jul;56(7):1022-32.\*

9. Martinez O, Gangi E, Mordi D, Gupta S, DOREVITCH S, Lefranc MP, Prabhakar BS: Diversity in the complementarity determining region 3 (CDR3) of antibodies from mice with evolving anti-TSHR antibody responses.” Endocrinology, Endocrinology. 2007 Feb;148(2):752-61.\*
10. DOREVITCH S, Demirtas H, Scheff P, Persky VW: “Bias and confounding in longitudinal measures of exhaled monoxides.” Journal of Exposure Science and Environmental Epidemiology, Sep;17(6):583-90 \*
11. DOREVITCH S, Tharenos L, Demirtas H, Persky VW, Artwohl J, Fortman J: “Inverse association between rural environment in infancy and sensitization to rodents in adulthood.” Annals of Allergy Asthma and Immunology. 2007 May;98(5):440-6.\*
12. Patel M, DOREVITCH S, Williamson R, Buchanan S: Pilot study investigating the effect of the static magnetic field from a 9.4 Tesla MRI on the vestibular system. Journal of Occupational and Environmental Medicine. 2008 May 50(5):576-583.\*
13. DOREVITCH S, Karandikar A, Washing GF, Walton GP, Anderson R, Nickels S: Efficacy of an air pollution education program in a community at risk for asthma morbidity. In press, J Asthma.
14. Wei H, Turyk M, Cali S, DOREVITCH S, Erdal S, Li A: Polybrominated Diphenyl Ethers in Dust: Particle size fractionation, evidence of debromination and human exposure. In revision, Environmental Science and Technology.

### **Research Funding**

Principal Investigator: NIOSH Pilot Project Research Training Award “Immunologic Risk Factors for Laboratory Animal Allergy,” 2001-2002. Total award \$15,844.

Principal Investigator: NIOSH Pilot Project Research Training Award “Immunologic Risk Factors for Laboratory Animal Allergy.” Renewed, 2002-2003

PI: NIEHS, NIH Research Career Award ES-K08ES011302 “Asthma and Demolition in Chicago Public Housing” Total award \$641,527 2002-2007.

Co-investigator: Laboratory Animal Allergen Production and Transport in a Working Animal Research Facility, PI: J. Artwohl,

Co-investigator: NIOSH/CDC, ERC Training Grant, T42/CCT522954-01, 07/01/03-06/30/08, \$5,552,668. (Conroy PI)

Co-investigator (UIC PI): Grand Boulevard Federation: Reducing air pollution impacts of Dan Ryan Expressway Reconstruction. USEPA NE96586801. Total award, \$49,515.

Principal Investigator: Asthma, Obesity and Airway Oxidative Stress. American Lung Association/Respiratory Health Association of Metropolitan Chicago. \$80,000. Funding period July 2007-June 2009.

Principal Investigator: Epidemiologic Study of Chicago Area Waterways. Metropolitan Water Reclamation District of Greater Chicago. Funding period May 2007-December 2009.

### **Teaching**

Course director, Occupational Medicine Weekly Conference

Lecturer, Environmental and Occupational Health Sciences Course, “Air Quality”

**Presentations at National Meetings**

2003 American Public Health Association Annual Meeting, San Francisco, CA. Housing Demolition and Air Pollution: Working with a local public housing environmental task force to minimize exposure. Poster Presentation.

May, 2005, American Thoracic Society International Conference, San Diego, CA. Particulate matter exposure adjacent to demolition of public housing.

May, 2006, American Thoracic Society International Conference, San Diego, CA. Elemental and organic carbon in PM<sub>2.5</sub> are associated with exhaled nitric oxide and exhaled carbon monoxide in inner-city asthmatics

May, 2006, American Thoracic Society International Conference, San Diego, CA. Exhaled carbon monoxide in inner-city asthmatics is associated with ambient ozone concentrations two days earlier.

November, 2006, American Public Health Association, Boston, MA. Science, Politics and Air Quality Policy.

May, 2007, American Thoracic Society International Conference, San Diego, CA  
Elemental Carbon and Organic Carbon in PM<sub>2.5</sub> Are Associated with Exhaled Nitric Oxide and Exhaled Carbon Monoxide in Inner-City Asthmatics

May, 2007, American Thoracic Society International Conference, San Diego, CA Exhaled Carbon Monoxide in Inner-City Asthmatics Increases 1-2 Days after Ambient Ozone Exposure



### **Presentation at State and Local Meetings**

May, 2004, Illinois Public Health Association “Beat Asthma in Illinois”, Springfield, IL.  
Community health educators as key personnel in inner city asthma research.

November, 2006, Chicago Asthma Consortium Data Conference, Chicago, IL. Air  
pollution and lung inflammation among public housing residents.

February, 2007, UIC Medical Center Pulmonary Medicine, Air Pollution and Health: Epidemiologic  
Methods

### **Other**

Reviewer, *International Journal of Occupational and Environmental Health*, 2000

Reviewer, *Journal of Occupational and Environmental Medicine*, 2002

Reviewer, *American Journal of Public Health*, 2004

Reviewer, *Archives of Occupational and Environmental Health*, 2006-7.

Scientist Reviewer, CDC/ASTPM/ASPH/AAMC Special Emphasis Panel, Atlanta,  
Georgia June 7-8, 2004

Testimony at public hearings: OSHA proposed ergonomics standard hearings, 2000.

Testimony at public hearings: US EPA proposed offroad diesel hearings, June, 2004.

Testimony at public hearings: US EPA proposed PM2.5 standard, March, 2006

Testimony at public hearing: US EPA proposed ozone standard, September, 2007

Member, Illinois Department of Transportation “Dan Ryan Health and Environmental  
Focus Group”, 2004-present.

Testimony before Chicago City Council Transportation Committee regarding the Dan Ryan  
Expressway reconstruction, May 15, 2006.

Invited member, Governor’s Blagojevich’s Illinois Climate Change Advisory Group,  
January-October, 2007.

**Licensure and Certification**

Medical license, State of Illinois, 1990-present

Board Certified, Emergency Medicine, 1994-present

Board Certified, Preventive Medicine/Occupational Medicine, 2002-present

Instructor, Advanced Cardiac Life Support, 1994-2006

### CHEERS monthly enrollment of 4,402 participants, by group, through July, 2008

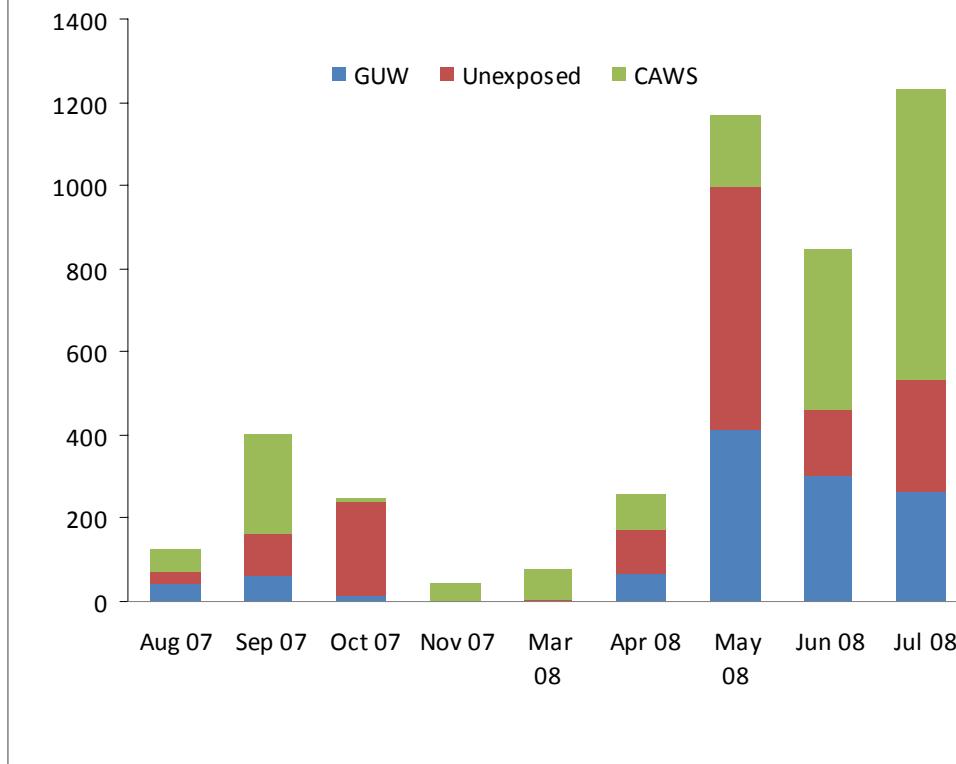

This figure displays monthly recruitment of participants, by group, by month who complete the second field interview. CAWS: Chicago Area Waterways System group; G UW: General Use Waters group.

UNIVERSITY OF ILLINOIS  
AT CHICAGO

Division of Environmental and Occupational Health Sciences (MC 922)  
School of Public Health  
2121 West Taylor Street  
Chicago, IL 60612

Dr. Tom Granato  
Assistant Director, Research and Development Department  
Metropolitan Water Reclamation District of Great Chicago  
6001 W. Pershing Road  
Stickney, IL

Dear Dr. Granato,

An element of the Epidemiologic Study of Recreational Use of the Chicago Area Waterways, also known as CHEERS, has been a characterization of usage of the waterway. This letter reports our work, to date.

Methods of Characterizing Water Usage

Over the course of the 2007 data collection season, UIC staff has recorded rates of recreational use of the waterways at various locations. The methodology for the use survey involved counting the number of new users on given day, at a given location, for a specific activity. Thus, a boat carrying three people would be counted as three users rather than one event. An individual who boated and then fished would be counted twice, once for each recreational activity. In order to prevent counting the same user twice for the same activity on a given day, and to estimate the number of new users per unit of time, we did not count people passing by a launch point. Thus, users who were observed passing or exiting a launch point were not counted, to ensure that individuals were not counted both at launch and again while they were engaged in (or finishing) their water recreational activity.

Results of Observations

Data were collected on a total of twenty-two days of observation. Generally, study personnel conducted the usage survey at one to two locations per day. This generally occurred on days and at times that participants were being recruited into the CHEERS study. The average duration of observation per site per day was 4.7 hours. This data includes participants at the Chicago River Flatwater Classic, which were recorded as using the waterways at Clark Park. Table 1 summarizes the amount of time spent collecting use data, by site.

<b>Location</b>	<b>Days of observation</b>	<b>Total hours of obs.</b>	<b>Avg. hrs/day of obs.</b>	<b>Avg. start time</b>	<b>Avg. end time</b>
Alsip	3	15.5	5.2	8:00 AM	1:00 PM
Worth	3	19	6.3	7:00 AM	1:00 PM
North	3	13	4.3	1:00 PM	5:00 PM
Clark	4	18	4.5	9:00 AM	1:30 PM
River Park	2	10	5.0	7:30 AM	12:30 PM
Skokie Rowing Ctr.	7	28	4.0	1:00 PM	5:00 PM
<b>TOTAL</b>	<b>22</b>	<b>103.5</b>	<b>4.7</b>		

Table 1: Summary of amount of time spent collecting use data, by site

Tables 2 and 3 present usage by category, by location, and Table 4 summarizes overall usage by location. Figure 1 presents the overall distribution of recreational users.

Location	<u>Boaters</u>		<u>Canoeists</u>		<u>Rowers</u>		<u>Kayakers</u>	
	Total	(per hour)	Total	(per hour)	Total	(per hour)	Total	(per hour)
Alsip	215	(13.9)	0	(0.0)	0	(0.0)	0	(0.0)
Worth	108	(5.7)	0	(0.0)	1	(0.1)	0	(0.0)
North	6	(0.5)	26	(2.0)	86	(6.6)	0	(0.0)
Clark	0	(0.0)	428	(23.8)	0	(0.0)	222	(12.3)
River Park	0	(0.0)	0	(0.0)	0	(0.0)	0	(0.0)
Skokie Row. Ctr.	35	(1.3)	7	(0.3)	520	(18.6)	25	(0.9)
<b>TOTAL</b>	<b>364</b>	<b>(3.5)</b>	<b>461</b>	<b>(4.5)</b>	<b>607</b>	<b>(5.9)</b>	<b>247</b>	<b>(2.4)</b>

Table 2: Observed uses and hourly usage rates for boaters, rowers and paddlers, by category and location. Clark Park data includes the Flatwater Classic.

Location	<u>Fishers</u>		<u>Waders</u>		<u>Jet skiers</u>		<u>Water skiers</u>		<u>Swimmers</u>	
	Total	(per hour)	Total	(per hour)	Total	(per hour)	Total	(per hour)	Total	(per hour)
Alsip	0	(0.0)	0	(0.0)	2	(0.1)	0	(0.0)	0	(0.0)
Worth	2	(0.1)	0	(0.0)	2	(0.1)	0	(0.0)	0	(0.0)
North	0	(0.0)	0	(0.0)	0	(0.0)	0	(0.0)	0	(0.0)
Clark	2	(0.1)	6	(0.3)	0	(0.0)	0	(0.0)	0	(0.0)
River Park	7	(0.7)	0	(0.0)	0	(0.0)	0	(0.0)	0	(0.0)
Skokie Row. Ctr.	0	(0.0)	0	(0.0)	0	(0.0)	0	(0.0)	0	(0.0)
<b>TOTAL</b>	<b>11</b>	<b>(0.1)</b>	<b>6</b>	<b>(0.1)</b>	<b>4</b>	<b>(0.0)</b>	<b>0</b>	<b>(0.0)</b>	<b>0</b>	<b>(0.0)</b>

Table 3: Observed uses and hourly usage rates, for fishers, waders, jet skiers, water skiers and swimmers.

Location	<u>All uses</u>	
	Total	(per hour)
Alsip	217	(14.0)
Worth	113	(5.9)
North	118	(9.1)
Clark	658	(36.6)
River Park	7	(0.7)
Skokie Rowing Center	587	(21.0)
<b>TOTAL</b>	<b>1700</b>	<b>(16.4)</b>

Table 4: Observed uses and hourly usage rate, all recreational categories

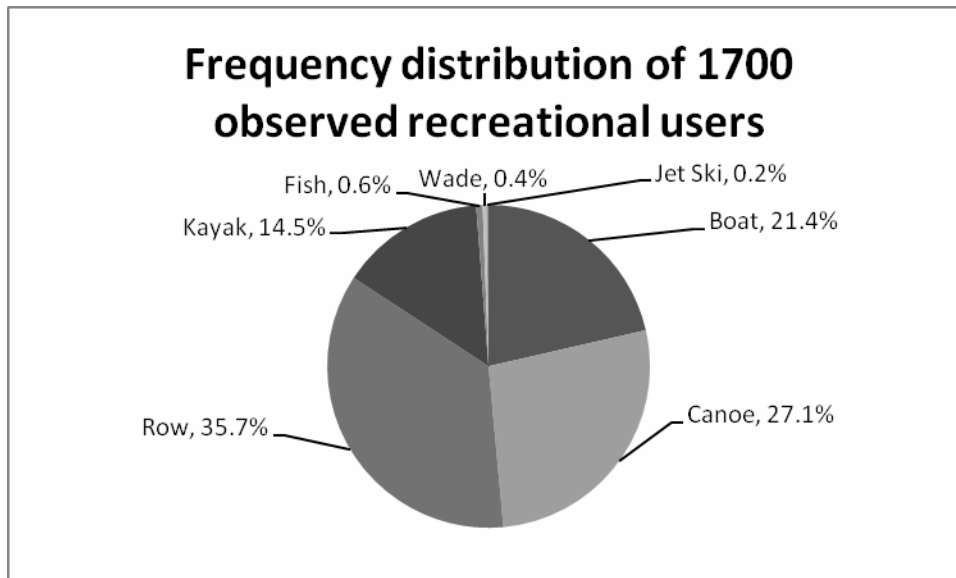

Figure 1: Overall use, by recreational category

In addition to the uses recorded on the twenty-two days that the use survey was conducted, study personnel surveyed numerous other potential access points in two ways. One was by land-based site visits. The other was on a survey of the North Branch of the Chicago River and lower North Shore Channel by boat. Paddling, rowing and boating were observed on these surveys; however, swimming, jet skiing, and water skiing were not.

### Interpretation of Data

Several factors should be taken into consideration when interpreting the above data. First, the dates and times of observation were not randomly selected. Surveys were generally conducted when usage was expected to be relatively heavy--on weekends, when rowing teams and clubs used the waterways, and during a major rowing/paddling event. Thus, multiplying hourly usage rates by the number of hours in a recreation season would grossly overestimate actual usage. Second, recreational users of the waterways were counted regardless of their eligibility to enroll in CHEERS. For example, rowers who would enroll in the CHEERS study on Monday would not be eligible to enroll on Tuesday (there is a 21 day period of follow-up during which current participants are not eligible to re-enroll). Nevertheless, they would have been counted on both days of the use survey. Members of rowing teams typically practice or compete 4-7 days per week on the waterways for as many as 8 months per year. Thus, the number of uses greatly exceeds the number of users and the number of users eligible to enroll in CHEERS.

The data summarized in the above tables contrasts with data summarized in the Use Attainability Analysis (UAA), conducted for the Illinois Environmental Protection Agency. Notably, fishing accounted for 73% of the activity observed on the North Shore Channel, 25% of the activity on the North Branch of the Chicago River, 34% of the activity on the Cal-Sag Channel, and 64% of the activity of the Little Calumet River. By contrast, fishing accounted for less than 1% of all activity noted in our use survey. Power boating accounted for 32% of activity on the North Branch in the UAA while it is observed infrequently in our study at North Branch locations. Differences in the findings of the two studies are likely due to differences in

methodology, and the protocol employed in the UAA use survey would be helpful in understanding these differences.

If you would like further information or clarification of our methods and results, please contact me.

A handwritten signature in black ink, appearing to read 'Sam Dorevitch', with a long horizontal flourish extending to the right.

Sam Dorevitch, MD, MPH

# CHEERS: THE CHICAGO HEALTH, ENVIRONMENTAL EXPOSURE, AND RECREATION STUDY

## STUDY OVERVIEW

### Title and Approval Sheet July 29, 2008

University of Illinois at Chicago School of Public Health  
Division of Environmental and Occupational Health Sciences  
Division of Epidemiology and Biostatistics  
2121 W. Taylor, M/C 922  
Chicago, IL 60612



Samuel Dorevitch, MD, MPH  
Study Director



Date

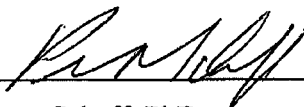

Peter Scheff, PhD  
Quality Manager

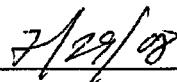

Date



## Table of Contents

<b>Organization of this protocol</b>	1
<b>Background</b>	2
1. Chicago Area Waterways	2
2. Water Quality Regulation	2
3. Scientific Background	7
4. Limitations	10
5. Epidemiologic Study	11
<b>Study Objectives</b>	13
<b>Field study overview and design considerations</b>	14
1. Field study summary	14
2. Approach to choice of study methods	14
3. Rationale for prospective cohort design	15
4. Study groups	16
5. Estimating background rates for sample size calculations	17
6. Study name	18
7. Participant recruitment strategies	18
8. Study enrollment and locations	23
9. Survey data	30
10. Clinical microbiology	32
11. Human research subject protections	33
12. Overview of water sampling	35
13. Field team organization	37
14. Project management	38
15. Communications plan	44
<b>References</b>	45
<b>List of Tables</b>	iii
<b>List of Figures</b>	iii
<b>List of Appendices</b>	iv
<b>List of Acronyms</b>	iv

## List of Tables

<u>Table</u>	<u>Description</u>	<u>Page</u>
Table 1	Terms used to describe water recreational activities based on degree of contact	5
Table 2	Summary of 2007 recruitment efforts, projected 2008 recruitment efforts	29
Table 3	Study participant recruitment achieved during 2007, targets for 2008	30
Table 4	Pathogens to be detected in stool samples	33
Table 5	Primary purposes of water sampling, by location	36
Table 6	Locations for water sampling on the CAWS other than recruitment sites	36
Table 7	Water sampling locations, by site of participation enrollment	37

## List of Figures

<u>Figure</u>	<u>Description</u>	<u>Page</u>
Figure 1	Chicago Area Waterways (CAWS) map	6
Figure 2	Overview of study components	15
Figure 3	Recruitment locations, 2007 and 2008 seasons	25
Figure 4	Usual Incubation Period ranges for selected etiologic agents	34
Figure 5	Shedding period and optimal collection period for select agents	34
Figure 6	Project management	43

## List of Appendices

<u>Appendix</u>	<u>Description</u>
Overview 1	CHEERS Logo
Overview 2	Publicity Flyer
Overview 3	Information for clubs, teams organizers and vendors
Overview 4	Water Quality FAQ Sheet
Overview 5	Recruitment sites – CAWS
Overview 6	Recruitment sties – GUW
Overview 7	2007 recruitment schedule
Overview 8	2008 recruitment schedule

## List of Acronyms

---

AGI	Acute Gastrointestinal Illness
A-SPM	Assistant Survey Project Manager
CAI	Computer Assisted Interview
CAPI	Computer Assisted Personal Interviewing
CATI	Computer Assisted Telephone Interviewing
CAWS	Chicago Area Waterways System
CDC	Centers for Disease Control and Prevention
CFC	Continuous Flow Centrifugation
CFU	Colony Forming Units
CHEERS	Chicago Health, Environmental Exposure, and Recreation Study
COC	Chain of Custody
CPM	Clinical Project Manager
CSOs	Combined Sewer Overflows
DQO	Data Quality Objective
EPA	Environmental Protection Agency
FCR	Friends of the Chicago River
FDS	Field Data Sheets
GUW	General Use Waters
IDPH	Illinois Department of Public Health

IEPA	Illinois Environmental Protection Agency
IPCB	Illinois Pollution Control Board
IPR	Initial Precision and Recovery
IRB	Institutional Review Board
MB	Method Blank
MS	Matrix Spike
MSD	Matrix Spike Duplicate
MWRDGC	Metropolitan Water Reclamation District of Greater Chicago
NBCR	North Branch Chicago River
NEEAR	National Epidemiological and Environmental Assessment of Recreational waters study
NGI	Non-gastrointestinal Illness
NSC	North Shore Channel
OPR	Ongoing Precision and Recovery
OSS	Office of Survey Systems
PFU	Plaque Forming Unit
QA	Quality assurance
QAPP	Quality Assurance Project Plan
QC	Quality Control
QMP	Quality Management Plan
QRC	Questionnaire Review Committee
RR	Relative Risk
SAS	Statistical Analysis Software
SMI	Scientific Methods Incorporated
SPH	School of Public Health
SPM	Survey Project Manager
SRL	Survey Research Laboratory
TNTC	Colonies Too Numerous to Count
UAA	Use attainability analysis
UIC	University of Illinois at Chicago
UIH	University of Illinois Hospital
USEPA	United States Environmental Protection Agency
WERF	Water Environment Research Foundation
WRP	Water Reclamation Plant

## **ORGANIZATION OF THIS PROTOCOL**

The Chicago Health, Environmental Exposure, and Recreation Study, or “CHEERS,” is a multi-year, multi-site, interdisciplinary epidemiologic study being conducted by a research team at the University of Illinois at Chicago (UIC) for the Metropolitan Water Reclamation District of Greater Chicago (MWRDGC). When initially proposed, this study was called the “Epidemiologic Study of Recreational Use of the Chicago Area Waterways.” It consists of three distinct but interrelated data-collecting activities, which are organized as separate projects within the larger study. Each project has its own Quality Assurance Project Plan (QAPP). The study protocol is organized into six major sections:

- Study Overview (this document)
- Organization-wide Quality Management Plan (QMP)
- QAPP #1: Water Sampling and Analysis
- QAPP #2: Survey Methods
- QAPP #3: Clinical microbiology
- Statistical Analyses

The Study Overview and Organization-wide QMP are referred to throughout the individual QAPPs and should be read first. Key analyses will involve data generated by two or more individual projects within the larger study, therefore, the approach to statistical analyses are presented in a separate document. Numbering of pages, tables, figures, and appendices is specific to each of the six documents (in other words, numbering begins at 1 for each of these major components of the overall study protocol).

## **BACKGROUND**

### **1. The Chicago Area Waterways System (CAWS)**

The Chicago Area Waterways System (CAWS) is a 78-mile-long, primarily man-made series of channels and rivers. It is partly natural but irreversibly modified. The CAWS includes the North Shore Channel, the North and South Branches of the Chicago River, the Chicago River, the South Fork of the Chicago River (Bubbly Creek), the Chicago Sanitary and Ship Canal, the Calumet-Sag Channel, the Calumet River, the Little Calumet River, the Grand Calumet River, and Lake Calumet (Figure 1). The primary purpose of the system is to provide an outlet for urban drainage in order to protect Lake Michigan, the source of drinking water for Chicago and many nearby communities. Other purposes include transportation, commerce, and recreation. The waterways also provide aquatic wildlife habitat. Four water reclamation plants (WRPs) of the Metropolitan Water Reclamation District of Greater Chicago (MWRDGC) release secondary-treated effluent (i.e., non-disinfected sewage) into the CAWS. It has been estimated that 70% of the annual flow in the system is effluent from the WRPs (UAA). Storm runoff and combined sewer overflows (CSOs) during and immediately after significant rainfall introduce water and contaminants into the CAWS.

### **2. CAWS water quality regulation**

#### **2.1. Current CAWS use designations**

The Illinois Pollution Control Board (IPCB) establishes use designations for bodies of water in Illinois. Most of the CAWS is designated Secondary Contact and Indigenous Aquatic Life. This designation allows recreational activities during which water contact is incidental or accidental and for which the probability of ingesting appreciable quantities of water is minimal, including canoeing, kayaking, and fishing, but not jet skiing or swimming. Three relatively small portions of the system (the upper North Shore Channel, the Chicago River, and Calumet River) are designated for general use. These use designations are not associated with a microbial water quality standard.

#### **2.2. Proposed changes to CAWS use designations**

Because of water quality improvements in recent years, the Illinois Environmental Protection Agency (IEPA) has recommended a use upgrade for parts of the CAWS that are now designated Secondary Contact Recreation and Limited Aquatic Life. These improvements

stem from efforts by the State of Illinois to meet the goal of the Clean Water Act to make all bodies of water “fishable and swimmable.” A change in use designation generally requires a Use Attainability Analysis (UAA), thus, the IEPA had a UAA for the CAWS performed by a contractor. The UAA included a review of current water quality, biodiversity, and uses of the CAWS. After convening a stakeholder advisory committee and summarizing CAWS water quality, current uses, and other data, the CAWS UAA recommended the creation of two CAWS use designation subcategories, which differentiate recreational uses from aquatic life uses.

Two recreational uses were proposed in draft form and posted on the UAA website in 2004<sup>1</sup>, 1) Recreational Navigation, which would apply to the Chicago Sanitary and Ship Canal, and 2) Limited Contact Recreation, which would apply to the other reaches of the CAWS that are currently designated Secondary Contact and Indigenous Aquatic Life. Under the Limited Contact Recreation use designation, canoeing, kayaking, fishing, jet skiing, and wading would have been permitted. This designation would have applied from March 1 to November 30 and required the attainment of a water quality standard intended to limit excess illness to 10 cases per thousand contacts (a 30-day geometric mean of 1,030 *E. coli* colony-forming units (cfu) per 100 mL). The Recreational Navigation microbial standard would have required the attainment of a standard meant to limit excess illness to 14 cases per thousand contacts (a 30-day geometric mean of 2,740 *E. coli* cfu per 100mL). Revisions to the Illinois Pollution Control Board regulations were proposed in draft form on January 18, 2007. In that document, the proposed recreational use designations were called “Incidental Contact Recreation” and “Non-contact Recreation,” and had the same bacterial water quality requirements, 1,030 and 2,740 geometric mean *E. coli* cfu per 100mL, as the “Limited Contact Recreation” and “Recreational Navigation,” respectively. Ultimately, the IEPA proposed one of three use designations for each segment, or reach, of the CAWS. These are non-recreational use, non-contact recreation, and incidental contact recreation. Microbial water quality standards to protect these use designations were not proposed; rather the IEPA recommended the disinfection of effluent discharged into the reaches of the CAWS designated for incidental contact and non-contact recreation.

A variety of terms have been used to categorize the degree of water contact expected to occur during water recreation activities (Table 1). In order to simplify the terminology used in this

protocol, and to be consistent with other publications, we use the term “secondary,” rather than “limited” or “incidental” contact recreation. For the purposes of this study, “secondary contact recreation” is defined as any recreational water activity in which water contact is limited to accidental or incidental contact, and precludes activities in which head immersion is likely to occur. Secondary contact recreational activities include non-motorized boating (paddling canoes or kayaks; rowing,) motor boating, and fishing (from a boat or from shore). Because head immersion is expected in activities such as water skiing, jet skiing, and boogie boarding, these activities are not considered part of our definition of secondary contact recreation. Kayaking or canoeing on the low-flow waters of the CAWS are not expected to result in head immersion. Again, the distinction between secondary contact recreational activities and primary contact recreational activities such as swimming and water skiing is that head immersion is not expected to not typically occur among secondary contact recreators, while it is expect to occur among primary contact recreators.



Name	Source	Key elements of definition
Incidental contact recreation	IEPA <sup>2</sup>	Human contact with water is incidental and the probability of ingesting appreciable quantities of water is minimal, such as fishing, commercial boating, small craft recreational boating, shoreline activities.
Non-contact recreation	IEPA <sup>2</sup>	Human contact with water is unlikely such as pass through commercial and recreational navigation
Limited contact recreation	UAA <sup>3</sup>	Incidental or accidental body contact, during which the ingestion of appreciable quantities of water is minimal, such as recreational boating (hand powered boating activity, canoeing, jet skiing) and any limited contact incident to shoreline activity, such as wading and fishing.
Recreational navigation	UAA <sup>3</sup>	Non-contact activities including, but not limited to, pleasure boating and commercial boating traffic operations.

Table 1. Terms used to describe water recreational activities based on degree of contact

# Chicago Area Waterway System (CAWS)

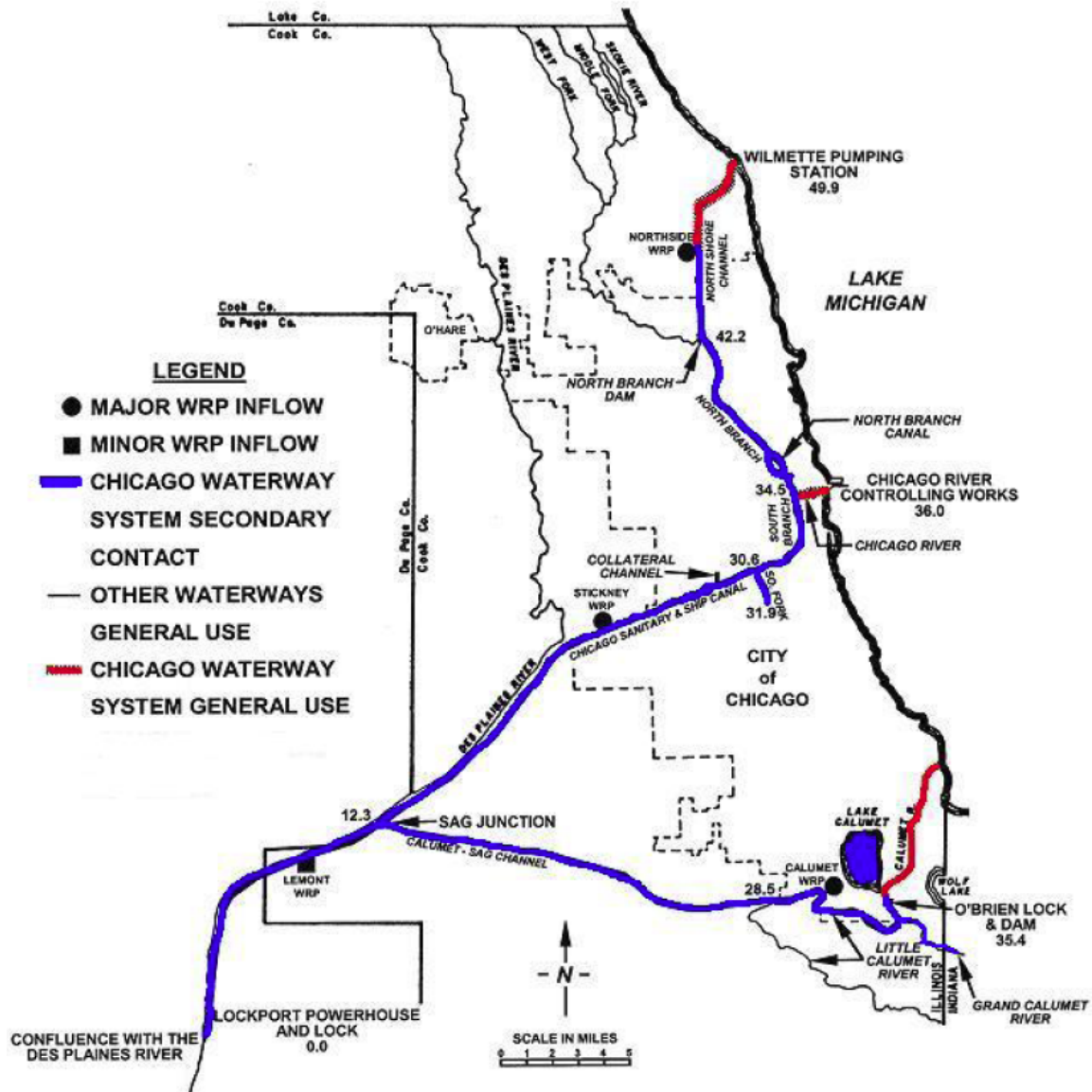

Figure 1. The Chicago Area Waterways (CAWS). Map produced by the MWRDGC

### 3. Scientific background for a CAWS microbial water quality standard

Four sources of information are useful for estimating health risks attributable to secondary contact recreation on the CAWS. These are: 1) prior epidemiologic studies of secondary contact recreation in other settings, 2) prior primary contact recreation studies, 3) the MWRDGC Expert Panel Report, and 4) the CAWS risk assessment produced for the MWRDGC.

#### 3.1. Prior epidemiologic studies of secondary contact recreation

Three studies have characterized rates or relative odds of illness among secondary contact recreators in other settings.

##### 3.1.1. Fewtrell 1992

This investigation was conducted at two freshwater canoeing courses in the United Kingdom, one of which was downstream of several sewage treatment facilities, and the other of which was on a “pristine” waterway.<sup>4</sup> Demographic information and risk factors for acute gastrointestinal symptoms were recorded at baseline. Water exposure while canoeing was assessed immediately following the event. Five to seven days later, symptoms were recorded by telephone survey and recorded again by self-administered postal survey 28 days after the event. Unexposed individuals were enrolled at each site as a reference group. Fecal coliforms, fecal streptococci, total staphylococci, and enterovirus concentrations were measured in water samples taken during the event. A total of 561 participants, 90% of those initially enrolled, completed the 5-7 day follow-up. The risk of developing gastrointestinal symptoms at 5-7 day follow-up was 4.25 times greater among those who canoed downstream of the sewage treatment facility than among those in the unexposed reference group. In other words, the relative risk (RR) of GI symptoms was 4.25, with a 95% confidence interval [CI] of 2.60, 6.94. Among recreators downstream of the sewage treatment facilities, the incidence of respiratory symptoms was also higher than among those without exposure (RR 2.42; 95%CI 1.55, 3.79), as were “flu” symptoms (RR 2.41; 95%CI 1.68, 3.45). Event participants on the cleaner body of water were more likely to develop respiratory symptoms than the reference group (RR 1.61; CI 1.01, 2.55), but not other symptoms. Between the 5-7 day follow-up and the 28-day postal questionnaire, 40 of 109 (37%) participants on the contaminated course reported the development of gastrointestinal symptoms. This rate was more than 50% higher than

that observed among those who canoed on the other body of water. The authors speculate that the development of symptoms between the first and third week post-event may have been due to infection by *Giardia* or *Cryptosporidium*. Because stool sample collection and analysis was not part of the study protocol, it was not possible to identify the pathogens responsible for acute illness.

### 3.1.2. Fewtrell 1994

Following up on the previous work, a prospective cohort study was conducted in which study subjects were enrolled at two rowing regattas and two canoe marathons in the United Kingdom.<sup>5</sup> A total of 591 event participants and unexposed spectators were enrolled in the study. A variety of demographic and behavioral characteristics were recorded prior to recreation. Five to seven days after the event, subjects were contacted by phone and postal survey, and asked about water exposure during the event; the subsequent development of symptoms was recorded. Water quality measures included fecal coliforms, fecal streptococci, staphylococci, *Pseudomonas auruginosa*, *Salmonella spp.*, and *Cryptosporidium spp.*, as well as enteroviruses. Those who ingested water were more likely to develop gastrointestinal symptoms (RR 2.20; CI confidence interval 1.35, 3.58) or any symptom (RR 1.35; CI 1.32, 2.32) compared to combined group of spectators and participants who did not ingest water. Actual rates of illness were not reported, nor were associations between rates of illness and measures of water quality. Another limitation of this study is that participants were asked five to seven days after the event about water exposure during the event. Recall bias may have occurred. For example, having become ill, those who developed symptoms may have been more likely to remember or report swallowing water during the event than those who did not become ill.

### 3.1.3. Lee 1997

A third study of 473 paddlers was conducted in the United Kingdom on a whitewater course<sup>6</sup>. Participants in whitewater events were given questionnaires and asked to mail in their responses one week after the event. Water quality measures included *E. coli*, enterococci, and F-specific RNA bacteriophages. The authors found that specific exposure variables predicted the development of symptoms. For example, the risk of illness was increased among those who reported swallowing water two or more times

compared to those who did not (RR 1.9; CI 1.0, 3.6). Accidentally falling in the course and swimming (RR 2.3; CI 1.2, 4.3), and eating or drinking before changing out of clothing worn during the event (RR 2.1; CI 1.1-4.0) were also risk factors for the subsequent development of symptoms. The risk was lower among those who used the slalom course seven or more times in the past year compared to less frequent users (RR 0.3; CI 0.1, 0.7). The absence of a reference (i.e., unexposed) group precludes estimating the risks of illness attributable to paddling in this setting.

#### 3.1.4. Other prior studies of secondary contact recreation

Several other papers have been published on related topics, though they do not help characterize the risks of secondary contact recreation. These include a characterization of the RNA of a norovirus-like pathogen that was isolated from stool samples of several canoeists, but did not include measures of water quality.<sup>7</sup> Illness rates among canoeists in South Africa have been described,<sup>8, 9</sup> though the pathogen of interest in those studies, *Schistosoma hematobium*, is not a pathogen of concern in North America.

### 3.2. Prior primary contact recreation studies

Recreational water quality standards have been based on epidemiologic studies of swimmers and bathers. The literature has been summarized in a review article<sup>10</sup> and a meta-analysis.<sup>11</sup> Many of the relevant primary contact research studies included in those reviews,<sup>12-15</sup> as well as three published since,<sup>16-18</sup> were prospective cohort studies, while several were randomized controlled trials.<sup>19-22</sup> Additionally, a case-control design was used in one study.<sup>23</sup> Furthermore, outbreaks of illness linked to recreational water exposure, generally involving primary contact recreation, have been reported through the ongoing Waterborne Disease and Outbreak Surveillance System of the US Centers for Disease Control and Prevention (CDC).<sup>24, 25</sup> The above studies generally address marine water or freshwater lakes, with very little known about health risks of primary contact in rivers. The above studies are fairly consistent in documenting an increased risk of illness with increasing indicator organism concentrations in recreational waters.

### 3.3. The MWRDGC Expert Panel Report

The MWRDGC convened an expert panel to evaluate the scientific basis for establishing a microbial water quality standard for the CAWS.<sup>26</sup> After reviewing the literature and relevant

proposed and established regulatory standards, the expert panel noted that “there are virtually no data available on which to rationally base criteria for secondary contact recreational exposure, either in freshwater or marine situations.” Given the paucity of knowledge about the risks of limited contact recreation, the Expert Panel recommended that “...studies to ascertain risk from secondary contact in freshwater and the relationship between any such risk and indicator levels need to be conducted. These may be epidemiological studies designed with sufficient statistical power to detect risks at levels deemed to be acceptable for regulatory purposes. Alternatively, a formal microbial risk assessment can be conducted...”

#### 3.4. The CAWS risk assessment produced for the MWRDGC.

A CAWS recreation risk assessment was conducted for the MWRDGC by GeoSyntech Consultants to compare the estimated health consequences of the current practice of not disinfecting WRP effluent to a scenario of disinfection.<sup>27</sup> That study involved sampling water at locations upstream and downstream on three CAWS WRPs. Samples were analyzed for a variety of bacteria, viruses and protozoa. Rates of illness were then modeled using risk established quantitative microbial risk assessment methods. The risk model is based on several assumptions and estimates, including waterway usage rates, distribution and duration of specific recreational activities, water ingestion rates for specific activities, and the infectious dose of specific pathogens. Environmental sampling was conducted in wet and dry weather. The risk assessment projected a low probability of developing gastrointestinal illness attributable to recreation (about 1 to 2 per thousand exposures) even for the most recreational users in areas of the CAWS in close proximity to the District’s WRPs.

### 4. Limitations of the literature for establishing a CAWS bacterial water quality standard

#### 4.1. Limitations of prior secondary contact studies

The studies of secondary contact discussed above have limitations, including (in one or more studies) the lack of a comparison of rates of illness to those in a group of unexposed individuals, the possibility of recall bias, and the fact that rates of illness were not reported.

The dominant activities on the Calumet system of the CAWS are boating and fishing,<sup>3</sup> which

were not evaluated in the UK river studies. Even the risks for CAWS canoeing can not be predicted with any precision based on the UK studies of canoeing, because exposure was likely much greater on a whitewater slalom course than on the low-flow conditions of the CAWS.

#### 4.2. Limitations of prior primary contact studies

The relevance of studies of primary contact exposure to the establishment of secondary contact standards is questionable.

4.2.1 The exposures are not comparable given the assumption that smaller quantities of water ingested (the presumed route of pathogen exposure) during secondary contact recreation than during primary contact recreation. Risk estimates derived from primary contact studies would be relevant to modeling risks for secondary contact activities if the amount of water ingested by swimmers could be compared to that of paddlers or fishers. Ingestion rates for swimmers have been determined among adults and children swimming in a pool.<sup>28</sup> If similar estimates were available for secondary contact recreation, extrapolation of risks from primary to secondary contact could be made, but such estimates have not been determined.

4.2.2 Additionally, there are no studies comparing rates of illness among swimmers to those among paddlers, boaters, or fishers in the same body of water. The National Epidemiological and Environmental Assessment of Recreation (NEEAR) study reported higher odds of illness among beachgoers who had head-immersion, body immersion, and any water contact, compared to those who had no water contact.<sup>18</sup> Because water quality at Great Lakes beaches is so different than at many CAWS locations, and because wading is so different than kayaking, extrapolating from other surface waters to the CAWS may not be justified.

### 5. The epidemiologic study of recreational use of the CAWS

As discussed, the existing literature of risk of illness following primary and secondary contact water recreation is insufficient for establishing a microbial water quality standard for the CAWS. Although the GeoSyntech risk assessment suggested a low risk, many of the assumptions used in the analysis have yet to be validated. In order to develop a scientific basis for establishing a

standard, on April 19, 2007 the MWRDGC Board of Commissioners voted to contract with the University of Illinois at Chicago (UIC) to conduct an epidemiologic study of recreational use of the CAWS. That study is CHEERS, and the remainder of this overview document describes its components.



## **STUDY OBJECTIVES**

The overall objective of CHEERS is to investigate illness associated with secondary contact recreation on the CAWS. Specific aims are:

- 1) To determine rates of acute gastrointestinal and non-gastrointestinal illness attributable to CAWS recreation.
- 2) To characterize the relationship between concentrations of microbes in the CAWS and rates of illness among recreators.
- 3) To identify pathogens responsible for acute infections among recreators, and to explore sources of those pathogens on the CAWS.

The purpose of this study is not to develop regulatory standards. The findings of this research may provide a scientific basis for the establishment of state or federal water quality standards.

## FIELD STUDY OVERVIEW AND DESIGN CONSIDERATIONS

### 1. Field Study Summary

A prospective cohort study design is being conducted in which the health of research participants is evaluated both prior to and following recreation. Three groups of participants are being enrolled: 1) CAWS recreators (the “CAWS group”), 2) recreators on Lake Michigan and other general use waters (GUW) (the “GUW group”), and 3) outdoor recreators without water exposure, such as joggers and cyclists (the “unexposed group”). An overview of study components is presented in Figure 2. After completing an eligibility screen and an informed consent process, participants complete two interviews in the field. The first interview collects basic demographic information, while the second, administered after recreation to the water-exposed groups, inquires about water contact. Participants also provide information regarding their health in general, and about risk factors for acute illness that are unrelated to water exposure. They are also asked about any open skin wounds and pre-existing infections of the eyes, ears, and skin. Water is sampled at the location of and on the same days as subject enrollment; rates of illness will be analyzed as a function of water microbe concentration. Clinical specimens for microbial analyses are obtained from participants who develop symptoms of acute gastrointestinal illness (AGI) and non-gastrointestinal illness (NGI). Subjects are contacted for follow-up telephone interviews at 2, 5, and approximately 21 days after enrollment. The major study elements are discussed in greater detail in each specific QAPP document.

### 2. Approach to Choice of Study Methods

The use of well-established methods was strongly preferred over innovation for the epidemiologic study design. The central components – a prospective cohort design, pre- and post-recreation evaluations of health, post-recreation evaluations of exposure, the content and methods of administering surveys, measures of water quality, and the enrollment of a reference group – are based on the methods employed by the previously discussed studies by Fewtrell,<sup>4</sup> Wade,<sup>17-18</sup> and Colford.<sup>4, 16-18</sup> Water sampling – direct grab samples and with mechanized large volume sampling – is being conducted using US EPA-approved methods. Novel statistical methods will not be developed. Rather, the approaches used in the NEEAR and other studies will be utilized, and analyses will be conducted using SAS, a widely accepted and thoroughly tested statistical software package.

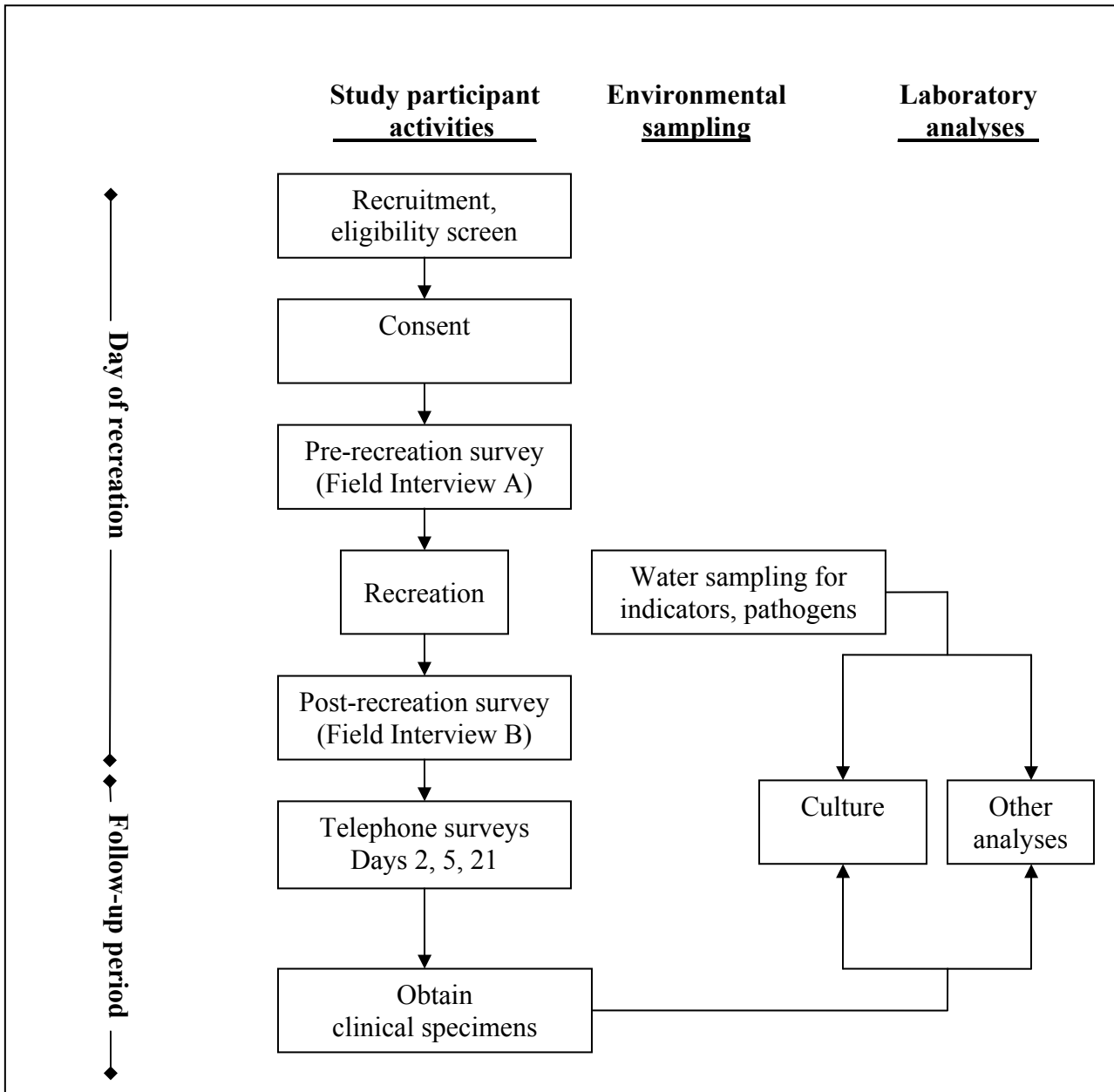

**Figure 2. Overview of study components**

### 3. Rationale for Prospective Cohort Design

While randomized controlled trial designs, such as that used in European primary contact studies,<sup>19-22</sup> have the advantage of the ability to equalize levels of confounders among study groups, such a design could not be effectively implemented in our setting. Almost all of the kayakers, canoeists, and boaters who come to the CAWS – particularly for events such as the Chicago River Flatwater Classic – will have planned in advance and brought their watercraft

with them. Such individuals would be unwilling to be randomized to a non-water-recreator group. Rather than addressing confounding by randomization, we will collect data about a variety of potential confounders and statistically adjust for the confounders in analyses. The prospective design will minimize recall bias because we will ask participants about water exposure immediately after recreation, rather than after some become ill.

#### 4. Study groups

Conceptually, there are three possible sources of risk for acute gastrointestinal and non-gastrointestinal illness among CAWS recreators:

- “Background” factors that result in AGI and NGI symptoms. For AGI these include existing population risks of food-borne illness, fecal-orally transmitted gastrointestinal infections, medication side effects, and lactose intolerance. For NGI, the relevant factors are population rates of acute respiratory, skin, eye, and ear symptoms.
- Acute illness due to recreational contact with water itself. Water can be aspirated, causing acute respiratory symptoms. Acute respiratory symptom rates have been noted to be higher among secondary contact recreators on a pristine whitewater course than among unexposed individuals, suggesting that water contact, rather than pathogen contact, is responsible for some symptoms (Fewtrell et al. 1992). Direct water contact promotes breakdown of the protective layer of the skin, increasing the risk of dermatitis and otitis externa (“swimmers ear”).
- Infections caused by waterborne pathogens that are acquired through recreational activities.

AGI is the best-studied health endpoint in studies of water recreation. There are substantial rates of AGI in the general population. Failure to account for background rates could result in some cases of AGI in water-exposed recreators to be attributed to water contact or pathogens, rather than to background factors. Such erroneous attribution would inflate estimated risks of illness due to microbial pathogen or water contact.

Data from the three groups of recreators will allow us to meet study objective 1, determining rates of illness attributable to CAWS recreation. We will differentiate the risk of acute illness following CAWS recreation from the risk attributable to microbial exposure on the

CAWS by enrolling three groups of study participants: CAWS recreators, G UW recreators, and unexposed (non-water) recreators. CAWS recreators have all three sources of risk. At recruitment locations which are not immediately downstream of wastewater treatment facilities, recreators in the G UW group have risks due to background factors and water contact, but will be exposed to much lower concentrations of waterborne microbes. The inclusion of the G UW group will allow the evaluation of a dose-response relationship between water quality and illness rates that will include a broader range of water quality measures than if only CAWS recreators were included. Risk for acute illness in the unexposed group, enrolled at the same times and areas as participants in the two water-exposed groups, will be due to “background” factors only. The fact that all three groups will consist of people engaging in outdoor recreational activities should reduce demographic and general health variables from confounding possible associations observed between illness rates and study group. Additionally, we will be able to examine self-reported measures of water exposure for various recreational activities, and to use this information in to help understand the variability of risk among study participants.

#### 5. Estimating background rates for sample size calculations

We estimate that background rates of AGI in the population are approximately 50-75 per 1,000 per month. This estimate is based upon rates of AGI in groups of unexposed individuals in the primary contact recreation studies<sup>16-18</sup> noted above that employed study designs and methods of defining health endpoints that are similar to those that will be used in the present study. In the NEEAR study, the overall rate of AGI among those without water contact was 80/1,000 during the 10-12 days following the beach visit.<sup>18</sup> However, in that study, the rate of AGI among unexposed beachgoers at the Indiana Dunes (located near Chicago) was 50/1,000. At the Lake Erie beach, the rate among the unexposed was also approximately 50/1,000, with the exception of one day when it exceeded 100/1,000 (personnel communication, T. Wade). In the Mission Bay, CA study, the rate among the unexposed was again approximately 75/1,000/month.<sup>16</sup> Another estimate of background rates for acute gastrointestinal symptoms comes from a large hepatitis A post-marketing surveillance study of US adults and children. In that study the rate of “diarrhea/gastroenteritis” requiring emergency department evaluation was 50/1,000 over a thirty day period.<sup>29</sup>

## 6. Study name

Although the name of this study when originally proposed to the MWRDGC was the “Epidemiologic Study of Recreational Use of the Chicago Area Waterways,” for the purposes of study publicity and recruitment, the study will be known as “CHEERS,” the Chicago Health Environmental Exposure and Recreation Study. We wish to avoid biasing potential study participants regarding the study’s hypotheses, and we will not identify the Chicago River (or other parts of the CAWS) as the primary focus of the research. Additionally, our promotional materials and recruitment scripts do not identify those who have no water contact as being a “control group,” so that all participants perceive that the information that they provide is no less important than that provided by individuals in the CAWS and G UW groups.

## 7. Participant recruitment strategies

Three general approaches will be employed to promote enrollment: day-of-recruitment efforts, advance coordination with organizers of special events, and advance coordination with teams or clubs. Study participants are also offered financial incentives for their time and effort. The efforts to recruit study participants are the responsibility of a recruitment manager.

### 7.1 Recruitment manager

Beginning in 2008, a member of the CHEERS team now functions as a recruitment manager and has primary responsibility for identification and contact of relevant organizations, and for the development of plans to work with clubs,/ teams, and organizers of secondary contact water recreation events in the Chicago area. In January, 2008, a dinner meeting was held with 25 representatives of yacht clubs, organizers of secondary contact water recreation events in the Chicago area, and high-school, collegiate, and private rowing and paddling clubs. The meeting was successful in allowing the research group to form new working relationships with organizations and to solidify existing relationships in order to promote recruitment of club/team members in the study. If recruitment goals are not met in 2008, a similar meeting will be held during the winter of 2009. In order to introduce the study to the target audience, the recruitment coordinators will also staff a CHEERS booth at non-recreation events that are attended by water recreation enthusiasts, such as conventions and sales conferences for water sports equipment.

## 7.2 Recruitment strategies

During the 2007 season, participants were recruited using three approaches. The “intercept interview” was the most frequently used. A recruiting station would be established at a location at which recreators were expected to be and recreators were approached by staff and invited to participate in the study. The second approach, event oriented recruiting, was used on two occasions: The Chicago River Flatwater Classic (a rowing and paddling event) and the Chicago Shoreline Marathon (a lake kayaking race). This approach involved the coordination of publicity and recruitment with event organizers. The third approach, club and team recruiting, was used several times in 2007 to recruit members of three rowing teams, a kayaking club, and a club that bicycles along Lake Michigan and the North Branch of the Chicago River. In the 2008 season we will vary the balance of the recruiting approaches over the course of the season in an effort to maximize recruitment.

### 7.2.1 Intercept interviews

In 2007, we relied primarily on intercept interviews at locations on Lake Michigan and the CAWS. These efforts were most successful on weekends. The number of participants recruited was related to the number of recruiting locations that could be staffed on a given day, and the number of staff available. In 2007, the number of staff available limited such recruiting to about 4-6 hours per day, generally on either Saturday or Sunday (but frequently not both on the same weekend) and generally at one location per day. In 2008, we have increased duration and staffing of intercept interview recruitment on dates when large numbers of participants are likely to be recruited, such as summer weekends and holidays, and have extended the length of the recruiting day from about five hours to between ten and twelve hours. Separate morning and afternoon/evening shifts are be staffed by approximately 4-5 people at each of three to four locations. The composition of a team (data manager, interviewer/recruiters, incentives/publicity, and use survey recorder [CAWS locations only]) remains unchanged. The positions are described in QAPP 2: Survey Methods. These eight teams (four locations, two shifts per location) are supervised by a field supervisor, one of the project managers.

### 7.2.2 Event-oriented recruiting

It is far more efficient to enroll participants at one large event than fewer participants on multiple dates. Our recruitment coordinator has identified at least number additional major events that will allow us to enroll participants at CAWS and general use waters locations. We will provide the organization hosting the event between \$50-\$250 to assist with publicity and distribution of information, such as links to our website and study information sheets. Several large rowing and paddling events will be held on CAWS and general use waters in 2008 and canoe/kayak vendors host smaller group outings on a regular basis. The amount of money provided to the organizers will vary based on the number of participants in the event, not the number who choose to enroll in the research study.

### 7.2.3 Club and team recruiting

Unlike events, in which several hundred people participate a single time, clubs and teams generally consist of 10-100 members, and have multiple outings per season. A problem with this type of recruitment is that members are often ineligible to enroll; many of the clubs and teams row 6-7 days per week and, to meet study eligibility requirements, participants must not have engaged in water activities 48 hours prior to enrollment. To address this issue, the recruitment manager works with coaches to set a date for CHEERS recruiting on which we can sign up team members on their first day out on the water, as well as on their first time back after spring and summer breaks. We have also simplified the process of enrolling members of high school rowing teams. Parents will have the option of providing consent once during the season for enrolling their children in the study as many times as they are eligible. As will be the case for event organizers, we will compensate clubs and teams for the time they put into helping coordinate recruitment. Teams will receive \$100 for their participation, regardless of the number of team members who enroll in CHEERS. If a school has four teams (men's and women's, varsity and novice) the school would receive \$400. Additionally, participants will have the option to donate the \$50 incentive to the team or club.

## 7.3 Participation incentives

Research participants will receive a CHEERS T-shirt and \$15 Target gift card on the day of field evaluation. Following the completion of the third and final telephone follow-up, they



will be sent a check for \$35. CHEERS participants recruited as members of a rowing or paddling team or club have the option to donate their incentive to the team, or to Friends of the Chicago River, a UIC research partner. Those who are asked to provide a stool or other clinical specimen for analysis (based on the presence of specific symptoms on telephone follow-up) will receive an additional \$75. These amounts were established based on the experience of UIC investigators in prior occupational and environmental epidemiologic studies. For example, in a study conducted by members of this research team about possible *Helicobacter* transmission in an occupational setting, offering a \$25 incentive resulted in 28 out of the 45 eligible workers (62%) providing stool samples and 28 of the 30 who enrolled in the study (93%).

#### 7.4 Study awareness and publicity

Various efforts have been undertaken to increase awareness of the study among potential participants.

##### 7.4.1 Logo

A logo has been developed to promote awareness of the study among local water recreation enthusiasts (Appendix 1). The logo was designed to convey messages of “outdoors” and “sports” without indicating that a specific body of water or regulatory issue is the focus of this research, so as not to bias study participants. The CHEERS study logo is displayed on the banners, T-shirts, and a recruitment flyer (Appendix 2) that is distributed in advance of group- and event-oriented recruiting, and during other recruitment.

##### 7.4.2 Informative handouts

###### 7.4.2.1 Recruitment flier

Like the logo, the recruitment flyer (Appendix 2) was designed to interest potential participants without communicating information that could result in biased enrollment (in other words, we do not wish to promote enrollment into the study in way that appeals more to those who perceive water quality to be particularly poor or particularly good). For example, although it is clear that this research is about water, outdoor recreation, and health, no message is communicated to suggest that CAWS recreation is either hazardous or risk-free. Similarly, the flyer does not state that some participants who enrolled to be

part of a “control group” rather than being in a group of primary interest. Additionally, although the financial compensation is presented as a range, \$50-\$125, but no mention is made of the fact that if participants note specific symptoms, they will receive a \$125 rather than \$50.

#### 7.4.2.2 General information about CHEERS

The “General Information about CHEERS: For clubs, teams, organizers, and vendors” sheet (Appendix 3) was developed to provide information to people contacted by the recruitment manager about the possibility of coordinating recruitment efforts. The flier outlines the basic goal of the study and what participation entails.

#### 7.4.2.3 Water Quality FAQ

Anticipating that our presence will prompt inquiries from the public regarding the quality of the waterways, we compiled a “Water Quality Frequently Asked Questions” sheet (Overview Appendix 4), based on information from publicly available government websites, including the Illinois EPA. The sheet allows study staff to provide standard, unbiased responses to common questions without offering opinions on water quality or health risks.

#### 7.4.3 Day of event publicity

On the day of recruitment multi-disciplinary field teams will set up a tent and banners at the site of recruitment. All CHEERS field team members will wear the CHEERS t-shirt which, like the banners and flyers, will display the study logo. After their participation in the field study, each research subject will receive a CHEERS T-shirt. To the degree that participants subsequently wear the T-shirts, they will be promoting recognition of the study “brand,” potentially facilitating recruitment of new participants.

#### 7.4.4 Recruitment assistance by Friends of the Chicago River

Friends of the Chicago River (FCR) is a non-profit organization that promotes the health and use of the Chicago River. FCR is an important partner in this research, helping to publicize the study, promote recruitment, and provide space at events for enrollment. FCR estimates that through its newsletter, website, special events, event promotion, club outreach, and other methods, it will promote awareness of the CHEERS study among

several thousand area residents. FCR organizes several urban canoe trips per season at various locations, as well as the “Chicago River Flatwater Classic,” a popular canoeing and kayaking event. FCR provides information to its members about the CHEERS study, and will provide specific enrollment information to those who register for the Flatwater Classic and selected other events.

#### 7.4.5 Website

In July, 2008, a website was launched to inform the public about this research. A goal of the website is to provide information about the study, and how one might enroll in it.

The web address of the site is [www.cheerschicago.org](http://www.cheerschicago.org).

## 8. Study enrollment and locations

### 8.1 Enrollment locations

#### 8.1.1 CAWS locations

The November 2004 Draft UAA report includes profiles of CAWS use by recreational activity and by waterway reach. Based on information in that report, the most heavily used access points on the Cal-Sag Channel are the boat launches of Alsip and Worth, from which approximately 7,000 and 4,000 launches occur per season respectively, making them by far the most active sites of recreation on the Calumet river system downstream of the Calumet WRP. At Clark Park on the North Branch of the Chicago River and at the Skokie Rowing Center Boat Launch on the North Shore Channel, the Chicago River Canoe & Kayak Rental Company estimates that a total of approximately 5,000 launches occurred in 2004. That number has reportedly increased to over 7,000 launches per year. Additionally, approximately 200 rowers per week use the CAWS as members of rowing clubs and school teams. After assessing these and twelve less frequently used access points on the CAWS in May 2007, we finalized the list of sites for the enrollment of study participants for the 2007 season. For the 2008 season, we will recruit at two new locations of the South Branch of the Chicago River (one for rowers, one for fishers), and at a second location at North Avenue on the west side of the turning basin. On the Cal-Sag Channel recruiting will also take place at new locations in 2008: Riverdale Marina, and at an aeration station near the Village of Worth boat launch.

### 8.1.2 G UW locations

We will expand the number of “general use waters” locations where recruitment will take place. In 2007 such recruitment took place at Lake Michigan harbors and beaches, the Skokie Lagoons, and Crystal Lake. In 2008 this has been expanded to include potentially the Fox, Des Plaines, Kankakee, and Du Page Rivers as well as two boating centers within the Cook County Forest Preserves: Busse Woods and Tampier Lake. The recruitment manager will work throughout the season to identify additional locations.

### 8.1.3 Study Area

All 2007 enrollment sites will be included in the 2008 season. The 2008 season will also incorporate additional CAWS and G UW sites. Enrollment sites visited during the 2007 and 2008 seasons are shown in Figure 3. Site specifications, including geographic coordinates and the occurrence of water and non-water activities can be found in Appendix 5 (CAWS locations) and Appendix 6 (G UW locations).

**Figure 3. Recruitment locations 2007, 2008 seasons**

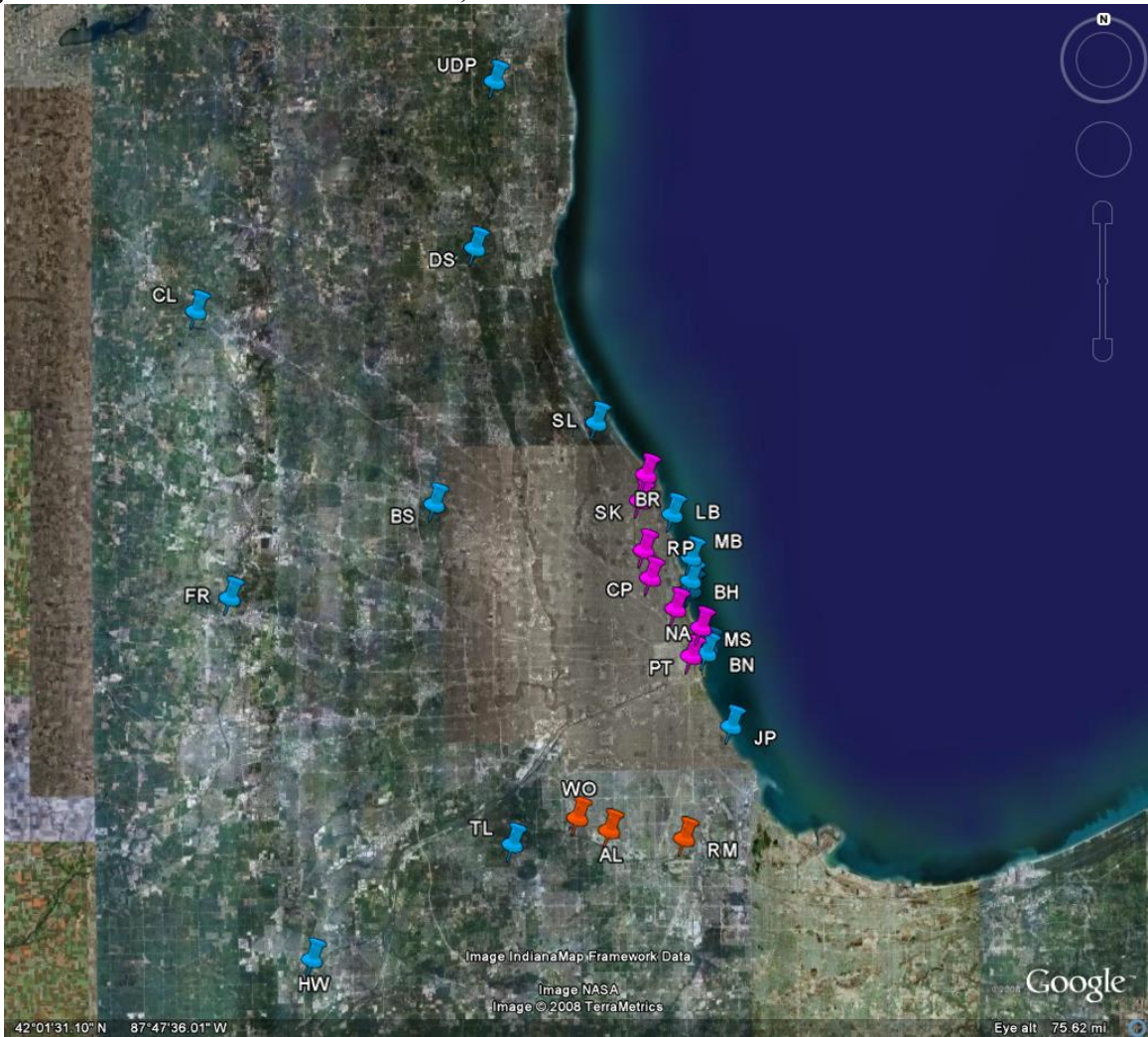

CAWS North (NSC, NBCR, MS, SBCR)

- BR: Bridge Street, Evanston, IL
- SK: Skokie Rowing Center, Skokie, IL
- RP: River Park, Chicago, IL
- CP: Clark Park, Chicago, IL
- NA: North Avenue, Chicago, IL
- MS: Main Stem, Chicago, IL
- PT: Ping Tom Park, Chicago, IL

CAWS South (Cal-Sag)

- WO: Worth Boat Launch, Worth, IL
- AL: Alsip Boat Launch, Alsip, IL
- RM: Riverdale Marina, Riverdale, IL

General Use Waterways

- UDP: Upper Des Plaines River, Wadsworth, IL
- DS: Des Plaines River, Libertyville, IL
- CL: Cystal Lake, Crystal Lake, IL
- SL: Skokie Lagoons, near Winnetka, IL
- BS: Busse Woods Boating Center, Elk Grove Village, IL
- FR: Fox River, St. Charles, IL
- LB: Leone Beach, Chicago, IL
- MB: Montrose Beach, Chicago, IL
- BH: Belmont Harbor, Chicago, IL
- DH: Diversey Harbor, Chicago, IL
- SD: Solidarity Dr., Chicago, IL
- BN: Burnham Harbor, Chicago, IL
- JP: Jackson Park Harbor, Chicago, IL
- TL: Tampier Lake Boating Center, near Palos Park, IL
- HW: Hammel Woods, Shorewood, IL

## 8.2 Scheduling enrollment by location

### 8.2.1 Theoretical considerations

Field study locations were selected based on the following principles relevant to data analysis and interpretation: 1) the activities and locations of enrollment of participants in the CAWS group should reflect actual CAWS usage patterns, by recreational activity and location; 2) the distribution of recreational activities among G UW group participants should reflect that observed in the CAWS group; and 3) the demographic characteristics of unexposed group participants should reflect that of the other two groups. The unit of “sampling” the population of recreators is done at the level of the recruitment site. At a given recruiting site, efforts are made to approach every water recreator and every non-water recreator within the pre-defined “recruitment area” (Appendices 5 and 6) at that site to avoid any potential selection bias on the part of the recruiters.

In order to ensure that the activities and locations of enrollment into the CAWS group reflect actual use, we will track enrollment and use by location on the CAWS. Several locations are relatively busy (Skokie Rowing Center, the east and west sides of the turning basin at North Avenue, Alsip, and Worth), while others are intermediate (Clark Park, River/Ronan Park), and others see relatively little use (Riverdale Marina, the Cal-Sag SEPAs and South Branch locations). We schedule recruitment at these locations in relation to actual use. In general, recruitment will take place at all busy locations every week of the summer (in 2008).

The study’s statistical power will be maximized if the participants are evenly distributed among the CAWS, G UW, and unexposed groups. Given that this is a dynamic cohort study into which new participants are enrolled every week, we have the opportunity to increase or decrease the frequency of recruitment of participants into the three groups in order to produce groups of equivalent size. If recruitment of one group of participants is lagging far behind the other two, the frequency of scheduling recruitment targeting that group will be increased. Maintaining three groups of equivalent size throughout the study is desirable for two reasons. First, it will produce a sample size that has higher statistical power. Second, if a community-wide outbreak were to occur (unrelated to water quality), all three groups would have a similar likelihood of capturing this outbreak if the groups are of comparable size. For these reasons, after each block of 1,000

participants is enrolled, the distribution of participants among the three groups is reviewed. If one or two groups are lagging significantly behind the other(s) (by more than 15%), the frequency of recruitment efforts targeting those groups are adjusted for the following month so that the lagging group(s) can catch up in enrollment to the largest group. This is done based strictly on recruitment rates per site (by group) and not based on measures of water quality or health events (such data is not available at the time of schedule revision).

### 8.2.2 Logistical considerations

Additionally, logistical considerations in the selection of study sites are: 1) waterway access; 2) the presence of nearby sites of recreational activities that do not involve water, which would allow the recruitment of participants into the unexposed group on the same days and at the same approximate location as the recruitment of participants in the CAWS or lake group; and 3) the physical safety of study personnel.

In the 2007 season, CHEERS enrollment was designed to progress from smaller to larger enrollment targets during the summer, and from enrolling participants from one access point per day to two access points per day (by two teams) during periods of anticipated heavy usage. In 2007, participant recruitment generally took place for 4-6 hours per day. In 2008, teams will work at four or five recruiting sites per day, with two shifts per site allowing up to 12 hours of recruitment. Based on the patterns of CAWS usage noted in the 2007 season, recruitment in 2008 will focus on recruiting rowing teams in clubs in the early morning or late afternoon, generally on weekdays during the academic year. Between Memorial Day and Labor Day, recruiting will take place every Friday, Saturday and Sunday, as well as on holidays at multiple sites per day.

The priorities for setting the recruitment calendar are: 1) organized races or events which often result in the greatest number of enrolled participants per hour, 2) availability and eligibility of clubs and teams, 3) more active recruitment sites over less active sites, and 4) increasing frequency of recruitment at sites where enrollment of participants into the “lagging” group is likely.

A summary of recruiting efforts during the 2007 season and proposed efforts for the 2008 season are listed in Table 8. The recruiting calendar for 2007 and the current calendar for 2008 can be found in appendices 7 and 8, respectively.



	2007	2008
Intercept interview locations x days	28	217
Events	2 (Flatwater Classic, Chicago Shoreline Marathon)	9 (Flatwater Classic, Chicago Shoreline Marathon, DesPlaines River Canoe Marathon, Kane County Canoe Marathon, Mid-America Canoe Race, Fox River Dragon Boat Race, Chicago River Dragon Boat Race, Chicagoland Bass Tournament, canoers and kayakers in Earth Day clean up)
Teams/Clubs	3 (New Trier, LPJ, Crystal Lake)	11 (New Trier, LPJ, Crystal Lake, St. Ignatius, Northwestern U., U of Chicago, Chicago River Rowing and Paddling Club, Chicago Rowing Club, Evanston Ecology Center, Lincoln Park Boat Club, North Park University)
Typical duration of field recruiting per day	4-6 hours	12 hours
Recruiting at 2 locations per day	4	2
Recruiting at 3 locations per day	2	16
Recruiting at 4 or more locations per day	0	38

**Table 2. Summary of 2007 recruitment efforts, projected 2008 recruitment efforts**

### 8.3 Enrollment targets by exposure group and study year

We plan to enroll a total of 9330 participants, based on considerations outlined in the Statistical Analysis document (which is not part of this “Overview” document). While we projected enrollment of 2,010 participants during the 2007 season, we successfully enrolled 886 study participants during the brief 2007 season, of whom 811 were eligible for telephone follow-up. The recruiting effort has been substantially increased in 2008, with the goal of recruiting the remaining 8,442 participants. Table 2 displays the overall recruiting targets by group, by year.

	<b>CAWS</b>	<b>Lake/Lagoon</b>	<b>Unexposed</b>	<b>Annual Total</b>
2007 (achieved)	386	123	377	886
2008 (projected)	2723	2986	2733	8444
<b>Group Totals</b>	<b>3110</b>	<b>3110</b>	<b>3110</b>	<b>9330</b>

**Table 3. Study participant recruitment achieved during 2007 and targets for 2008**

## 9. Survey data

9.1 The survey questionnaires being used in this study are derived from those used in the NEEAR study, conducted by the US EPA and CDC. Like the NEEAR study, we will use surveys to conduct pre-exposure enrollment, post-recreation exposure assessments, and post recreation health follow-up by telephone. Modifications to the NEEAR approach are: 1) the unit of recruitment (and interviewing) will be individuals, rather than family groups, and 2) exposure questions specific to secondary contact recreational activities have been added. The study was initially designed to conduct a pre-exposure health assessment questionnaire and a field clinical exam, and the first 130 participants were enrolled following this protocol. However, because the physical examination in the field by a clinician was considered a potential disincentive to participation and little information was gained from it, it was dropped from the protocol. The survey questionnaires were developed for this study in conjunction with the University of Illinois at Chicago (UIC) Survey Research Laboratory (SRL), a national leader in survey development, administration, and analysis. Elements of the survey portion of CHEERS are described briefly below. Detailed information is presented in QAPP 2: Survey Methods.

### 9.2 Questionnaires

A total of four questionnaires will be administered to all study participants:

- 9.2.1 An eligibility screen
- 9.2.2 A pre-recreation field questionnaire
- 9.2.4 A post-recreation field questionnaire
- 9.2.5 A telephone follow-up questionnaire

### 9.3 Questionnaire administration

Questionnaires will be administered in face-to-face interviews, with the exception of the follow-up questionnaire, which will be administered by telephone. The questionnaires will be administered using computer assisted interview (CAI) methods, with the exception of the eligibility screen. The CAIs conducted in the field will be administered using computer-assisted personal interviewing (CAPI) methods, while the telephone follow-up questionnaire will be administered using computer assisted telephone interview (CATI) methods. Field interviews will be conducted using laptop computers and the telephone interview will be conducted at UIC using desktop computers.

For children under the age of 7, parents will be required to provide proxy responses for the child; for children ages 8 through 17, parents have the option to serve as the proxy respondent. In both cases, parents are encouraged to accompany the child during the interview.

### 9.4. Health end-points

Using survey methods, we will determine whether each participant does or does not develop specific health endpoints. Key health endpoints to be identified are acute gastrointestinal illness and non-gastrointestinal illness:

- ♦ Acute gastrointestinal illness (AGI)

We will use two of definitions of AGI. One is based on the presence or absence of single symptoms (such as vomiting or diarrhea). The other is based on a syndrome of two or more symptoms. Prior studies have defined specific syndromes, and our study questionnaires and data analyses have been planned to allow comparisons of rates of such syndromes determined in our study to those in other studies. These definitions include Cabelli's "Highly Credible Gastrointestinal Illness"<sup>14</sup> and the definitions used the primary contact studies.<sup>16-18</sup>

- ♦ Non gastrointestinal illness (NGI)

Definitions for otitis externa, conjunctivitis, acute respiratory tract infections, and skin infections will be based on responses to questionnaire items. In addition to the above definitions, "culture positive AGI" will be defined as cases of AGI in which a pathogen is identified on stool analysis. Similar categories for culture-positive conjunctivitis and

skin/wound infection will be created though we expect few individuals to have such infections.

## 10. Clinical microbiology

10.1 Prior health studies of recreational water contact have relied upon telephone or postal questionnaires to define health endpoints (such as AGI). In other words, objective measures of health endpoints have been lacking. One exception is a primary contact study conducted in the United Kingdom conducted by Jones, et al.<sup>30</sup> In that randomized controlled trial of exposure to seawater, both water-exposed and unexposed participants were asked to bring stool samples three days before, three days after, and three weeks after the trial date. A total of 781 specimens were obtained from 276 participants, the vast majority of whom had no gastrointestinal symptoms. Two samples tested positive for *Salmonella spp.*, (one sample was obtained prior to the trial date), one for *Campylobacter spp.* (again, obtained prior to the trial date), none for *Cryptosporidium*, seven for *Giardia*, and five for enterovirus. Because of the small numbers of positive stool specimens, differences in the rates of infection by study group (exposed vs. unexposed) were not presented. In part because of the lack of positive findings in this study, investigations of the pathogens responsible for endemic (as opposed to outbreak-associated) recreational water illness were not conducted.

Based on the experience of Jones, we intend to only collect stool samples 1) after recreational activities, 2) from individuals with symptoms, and 3) by dispatching study personnel to pick up samples from the participants' homes. After participants who report specific symptoms at telephone follow-up are asked to provide a stool specimen, they will be told that they will receive an extra \$75 for their efforts. This is expected to provide additional motivation for the collection of samples.

## 10.2 Selection of pathogens

Pathogens of interest have been identified by reviewing recent publications by the Waterborne Disease and Outbreak Surveillance System of the US Centers for Disease Control and Prevention.<sup>24,25</sup> Additionally, data on pathogens in the CAWS have been evaluated.<sup>27</sup> Members of the UIC research team, two infectious disease physician/epidemiologists and the director of a university hospital microbiology laboratory, have assisted in defining the pathogens of interest, as presented in Table 3.

<b>Bacteria</b>	<b>Virus</b>	<b>Parasites</b>
<i>Salmonella</i> <i>Shigella</i> <i>Edwardsiella</i> <i>Yersinia</i> <i>Aeromonas</i> <i>Plesiomonas</i> <i>Campylobacter</i> <i>E. coli</i> 0157:H7	Norovirus Rotavirus Enterovirus Enteric adenovirus	<i>Entamoeba histolytica</i> <i>Giardia lamblia</i> <i>Cryptosporidium spp.</i> <i>Cyclorospira</i>

**Table 4: Pathogens to be detected in stool samples**

### 10.3 Timing of follow-up phone interviews

Based on information from an authoritative textbook of infectious diseases,<sup>31</sup> we devised a chart of the latency between exposure and AGI onset (Figure 4) and well as the optimal timing for collecting stool samples, given the period of shedding organisms in stool (Figure 5). This information was used to select days 2, 5 and 21 following recreation to conduct telephone follow-up and collect stool samples.

## 11. Human Research Subject Protections

This research study has been approved by the UIC Office for Protection of Research Subjects, Institutional Review Board (IRB). The UIC IRB protocol number is 2007-0436. Human research protection issues and the IRB process are described in detail in QAPP #2: Survey methods.

Further details about clinical sample collection analyses are described in QAPP #3: Clinical Microbiology and Evaluations.

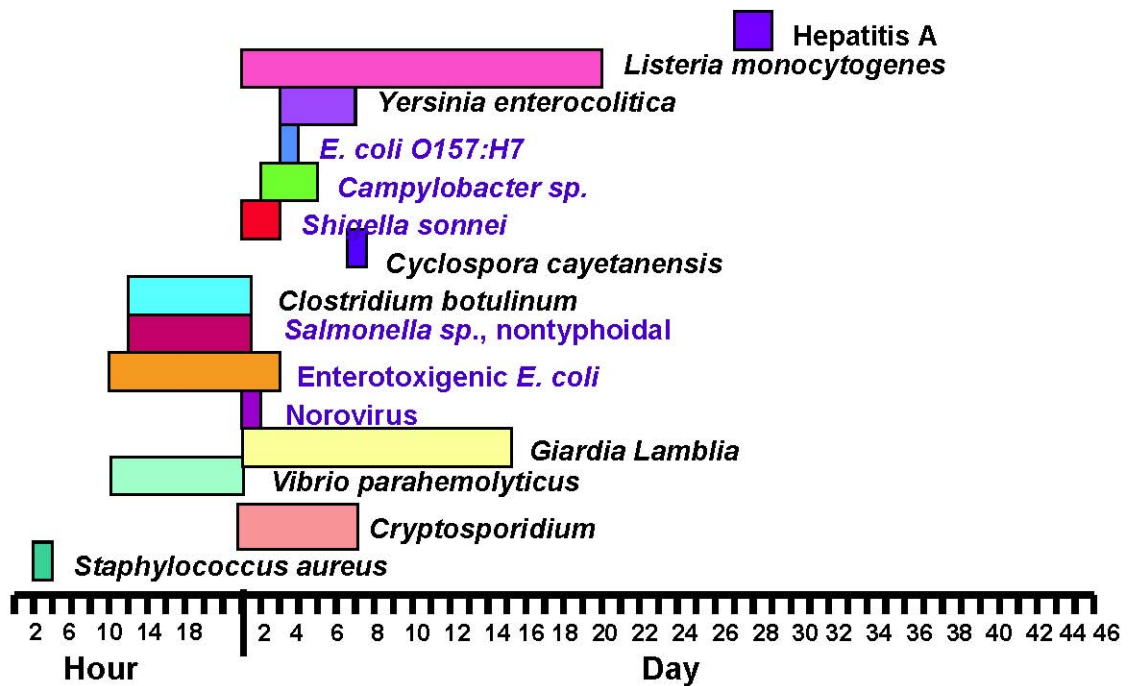

Figure 4: Usual incubation period ranges for selected etiologic agents

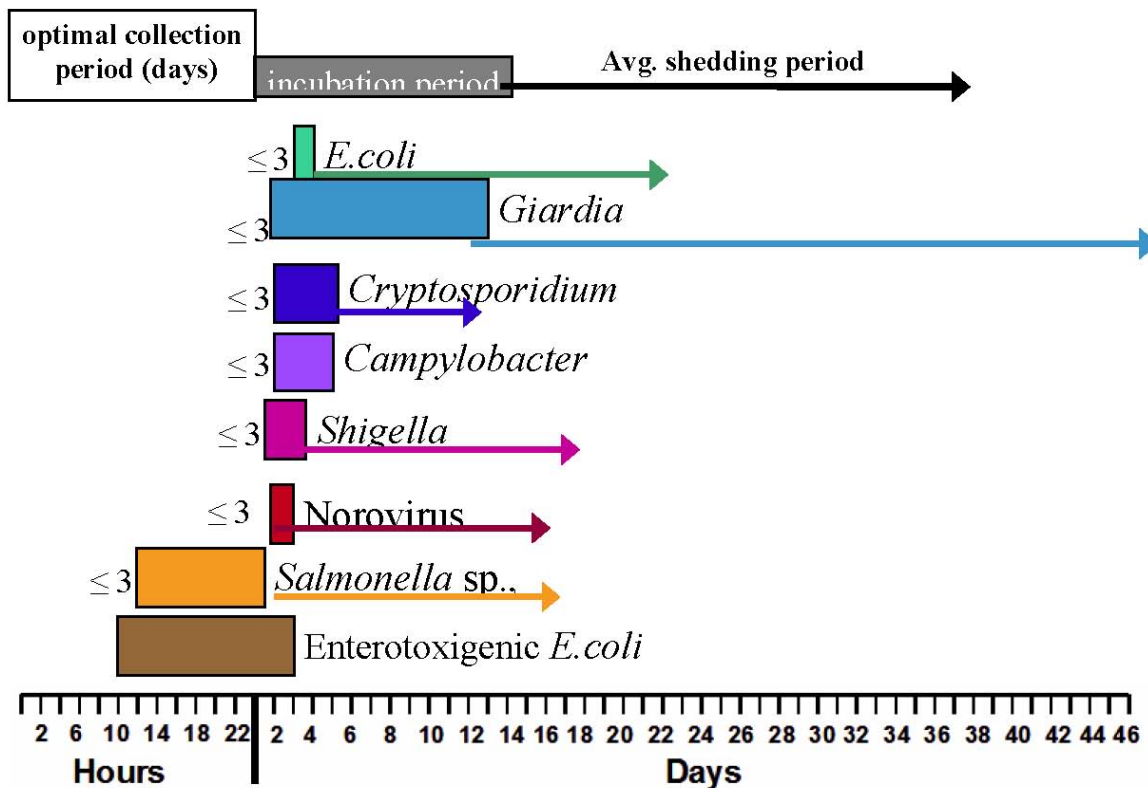

Figure 5: Shedding period and optimal collection period for select etiologic agents

## 12. Overview of Water Sampling

### 12.1 Purpose and types of water sampling

Water sampling and analysis will support study objectives 2 (characterizing the relationship between concentrations of water microbes and rates of illness) and study objective 3 (exploring sources of pathogens on the waterways). What follows is an overview of water sampling and analysis. Detailed information is provided in QAPP 1: Water sampling and Analysis.

Two types of water sampling will take place: direct sampling and large volume sampling. The large volume samples will be collected by the use of pumps which will collect water for continuous flow centrifugation (CFC) and for viral filtration. Direct sampling will be used to collect water for analyses of densities of indicator microbes *E. coli*, enterococci, and coliphages. CFC will be employed to collect water samples for analyses of *Giardia* and *Cryptosporidium*. Filtration samples will be analyzed for norovirus. Samples will be archived for potential future analyses.

### 12.2 Locations for Water Sampling

Water sampling locations will depend upon enrollment locations on any given date. For each enrollment location we will sample water every two hours at the approximate site of water entry (“access point sampling”). CAWS water will also be sampled upstream and downstream of the nearest upstream WRP, at the beginning and end of the enrollment day (“WRP sampling”). Additionally, for locations on the North Branch of the Chicago River, water samples will also be taken from the North Branch upstream of the North Branch dam. This location is important because at this location water that does not have an upstream WRP enters the CAWS from the North Branch of the Chicago River.

Categories of sampling locations were developed to support the analyses required for meeting specific study objectives. Table 5 presents the primary uses of water quality measures collected by location category. Health outcomes will be modeled using access point indicator densities, and also (separately) using downstream sampling site indicator organism densities. While access point measures may prove to be better predictors of health outcomes, sampling from a variety of access points will likely not prove practical in establishing water quality standards for the CAWS. Microbe densities measured in sampling collected at the fixed “downstream” sites could be a convenient measure used to define a sampling plan to comply with possible regulatory

requirements in the future. This distinction parallels the ongoing debate in recreational water illness epidemiology over whether the “ecologic exposure” or “personal exposure model” is preferable. Recent work indicates that in the primary contact setting any difference between the two approaches is small,<sup>32</sup> though it is not clear whether this will prove to be true for CAWS recreation.

Primary purpose	Access point	Upstream of WRP	Downstream of WRP	Upstream of NB dam
<b>Predicting health events</b>	√			
<b>Regulatory</b>			√	
<b>Illness-source linkage</b>		√	√	√

**Table 5. Primary purpose of water sampling, by location.**

The collection of water samples both upstream and downstream of the WRPs, as well as above the North Branch Dam (for North Branch access points) will allow the exploration of sources of pathogens responsible for illness among CAWS recreators. Table 6 presents locations for CAWS water sampling at sites other than participant recruitment locations.

WRP	Location	GPS coordinates	Nearest MWRD monitoring stations
North Side			
Upstream	Bridge Street	N 42°03.398' W87°42.025'	35, 101
Downstream	Lincoln Ave.	N 41°59.570' W87°42.605'	102
North Branch	NB Dam	N 41°58.426' W87°42.286'	37
Calumet			
Upstream	Beaubien Woods	N 41°38.983' W87°35.493'	55, 56
Downstream	Riverdale Marina	N 41°39.368' W87°38.830'	76

**Table 6. Locations for water sampling on the CAWS other than recruitment sites.**



On each day of participant enrollment and field evaluation, water will be sampled at the locations listed in Table 7.

Enrollment site	At access point	Upstream of WRP	Downstream of WRP	Upstream of NB Dam
Skokie Rowing Ctr.	√	Bridge Street	Lincoln Avenue	
River Park	√	Bridge Street	Lincoln Avenue	√
Clark Park	√	Bridge Street	Lincoln Avenue	√
North Ave. launches	√	Bridge Street	Lincoln Avenue	√
Worth Boat Launch	√	Beaubien Woods	Riverdale Marina	
Alsip Boat Launch	√	Beaubien Woods	Riverdale Marina	
Calumet Boat Launch	√	Beaubien Woods	Riverdale Marina	

**Table 7. Water sampling locations, by site of participant enrollment.**

### 13. Field Team Organization

The management structure of the overall epidemiologic study is described in a separate document, the “Quality Management Plan.” Each field team consists of approximately twelve UIC personnel, who perform logistical, water sampling, participant recruitment, and evaluation functions. The staffing level varies with daily recruiting targets. On days on which participants will be enrolled at two locations, two teams are simultaneously in the field. On those days, the water sampling and survey supervisors, water sampling staff, and equipment courier serve both locations. Each site has a dedicated data manager plus survey personnel and recruiters..For the 2008 season, twelve-hour recruiting efforts will employ 2 six-hour shifts of recruiters and interviewers.

#### Position (number in this capacity)

- Water sampling supervisor (1 per day)
- Direct method water sampling staff (2-4 per shift)
- Filtration method water sampling staff (2 per shift)
- Water chemistry and quality monitoring (1 per shift)
- Courier/driver (1 per shift)
- Survey supervisor (1 per day)
- Recruiter/interviewer (2-4 per site)

Field data manager (1 per site per shift)

#### 14. Project management

The management structure of CHEERS reflects the need to coordinate and ensure the quality of the diverse and interdependent elements of this project. Figure 6 outlines the positions and roles of members of the project management team. All work will be done at UIC, with the exception of the microbial measures of water quality, certain elements of study publicity performed by Friends of the Chicago River and some stool analyses to be performed by the Illinois Department of Public Health (IDPH). The study director, project coordinator, project managers, quality manager, and field coordinator comprise the leadership team of the project and have direct responsibility for its execution. Additionally, several UIC SPH faculty members have played critical roles in protocol development and will continue to provide ongoing consultation. All personnel are employed by the UIC School of Public Health unless otherwise indicated. Other important members of the research team and the roles that they play are included in the project-specific QAPP documents.

##### 14.1 Study director

The study director, Samuel Dorevitch, MD, MPH, will have overall responsibility for the development and implementation of the CHEERS study, as well as providing deliverables to the MWRDGC. Specific responsibilities of the study director include the hiring and supervising of project managers, establishing subcontracts with entities external to UIC, complying with human subjects research protection requirements, and communicating with the MWRDGC.

##### 14.2 Quality Manager

Peter Scheff, PhD, is the CHEERS quality manager. His responsibilities will include the development of the organization-wide QMP, as well as the four individual Quality Assurance Project Plans (QAPPs) for each component of the overall study. He has worked with the study director and assistant study directors to establish data quality objectives for individual projects. He will review the quality control data of the laboratories conducting water and medical sample analyses, conduct quality audits, and communicate with quality managers of the Survey Research Laboratory (SRL), UIC microbiology laboratory, IDPH microbiology, and microbial water quality laboratories.

### 14.3 CHEERS Project Manager

Sara Wuellner, MS, is the CHEERS project manager. The CHEERS project manager will have field, administrative, data management and quality monitoring functions. The CHEERS project manager will serve as a field supervisor and coordinate the three primary field data collection activities (water, survey, and clinical). The program manager will be responsible for ensuring that sufficient staff are available to conduct the field study, and will manage an online scheduling and staffing system. She will also track and consolidate incoming data from the laboratories and ensure the timely addition of the data to the central CHEERS database. The project manager will have responsibilities for organizing and maintaining study related documents (laboratory reports, data, IRB documents) and for report writing.

### 14.4 Survey Data Manager

The survey data manager will ensure the training of field team members and develop survey questionnaires based upon those used by the US EPA/CDC NEEAR study. Preethi Pratap, PhD, serving in this capacity, will also coordinate the review and programming of the questionnaires to be performed by SRL. She will also be responsible for training the field and telephone survey staff. Dr. Pratap will ensure the smooth transfer of data from field surveys to SRL, and from SRL to the telephone follow-up team. At field study events, she will serve as field data coordinator, and will ensure the accurate compilation of consent documents, the assignment of case ID's, unique identifiers for study participants, and the smooth flow of participants through the study process. Throughout data collection periods, the Survey Project Manager will track study enrollment, study completion by participants, and attrition from the study. The Survey Project Manager will coordinate staffing of the survey teams with the field coordinator.

### 14.5 Clinical Project Manager

Jacqueline Wuellner, RN, MPH, as the Clinical Project Manager will be responsible for the staffing and training of clinicians who will conduct field and home clinical evaluations, and the staff who will collect stool samples from homes of study participants. The Clinical Project Manager will be responsible for communications with the managers of the microbiology laboratories that will analyze medical samples. Together with the study Quality Manager, she will be responsible for establishing the identification and tracking procedures for medical samples.

#### 14.6 Water Project Manager

Margit Javor, MS, is the Water Project Manager, and will be responsible for the development of the water sampling protocol, standard operating procedures (SOPs), and the training of field staff to implement the protocol and SOPs. The water data manager will work closely with the field manager and quality manager to review data from the analytic laboratories to identify and promptly address deviations from the data quality objectives for water quality measurements. The water data manager will be responsible for staff that performs quality monitoring and water chemistry measures, as well as the training of all water sampling staff. The Water Project Manager will communicate with the laboratories that analyze water samples to ensure the prompt delivery of chain of custody forms and laboratory results.

#### 14.7 Field manager

The field manager will be responsible for the logistics of fieldwork. Todd Schoonover, MS, CIH, will ensure the smooth functioning of the water sampling portion of the study, and will be responsible for procuring and maintaining major study pieces of equipment, such as vehicles, boats, pumps, centrifuges, and refrigerators. He will ensure the transport of water samples to the commercial analytic laboratories. The field manager works closely with the Water Project Manager to ensure the implementation of the water sampling protocol by field staff. This will involve preparing all necessary timetables, labels, materials, and equipment for each day of field sampling. Mr. Schoonover will provide the water sampling schedule to the analytic laboratories and provide timely notification regarding any modifications to that schedule. The decision to cancel a day of field work due to a high probability (80% chance) of thunderstorms will be made by the field manager.

#### 14.8 Supply manager

Nicholas “Buck” Hanson, MPH, will be the project supply manager. He will be responsible for training and supervising staff who prepare the equipment and supplies for the field study. He will send mailings (including stool sample collection kits, when indicated) to study participants. He will monitor study supply inventories, order additional supplies as needed, and ensure delivery of supplies to the field. He will also have certain data management responsibilities.

#### 14.9 Biostatistician

Li Liu, PhD, will be responsible for merging study data from diverse sources into a single dataset for analysis. Dr. Liu will perform interim analyses following each recreation season, as well as a final analysis after all health data has been collected. She will review data analysis plans developed by members of the research team who will conduct parts of the data analysis, and provide consultation.

#### 14.10 Fiscal management

Anita Shaperd, of the Division of Epidemiology and Biostatistics at the UIC SPH, will coordinate the fiscal aspects of the study, including purchasing, accounting, and subcontracting. The fiscal manager will work closely with the personnel/human resources manager in the Division to hire and pay study personnel.

#### 14.11 Internal Consultants

Daniel Hryhorczuk, MD, MPH; Mark Dworkin, MD, MPH; Ronald Hershow, MD, MPH; and Leslie Stayner, PhD, have all assisted with the development of the study protocol. They will continue to advise on the implementation, analysis, and interpretation of results of the study.

#### 14.12 WERF Science Advisory Board

A group of independent, nationally-recognized experts on water microbiology, the epidemiology of recreational water-borne illness, infectious diseases, waste water treatment, and related fields, was convened by the Water Environment Research Foundation (WERF) to conduct peer review of the study before it was launched in the field. The same group now functions as a science advisory board, reviewing study progress, quality data and proposed changes to the study protocol. Lola Olabode of WERF coordinates the review/science advisory group.

#### 14.13 Friends of the Chicago River

Friends of the Chicago River (FCR) works to preserve, protect and foster the vitality of the Chicago River. FCR is trusted and respected by users of the Chicago River and will work to promote publicity about the CHEERS study among river users. Margaret Frisbie, Executive Director of FCR, will be responsible for working with UIC to disseminate the publicity message among river users.

#### 14.14 MWRDGC Liaison

Thomas Granato, PhD, will be the MWRDGC's contact for communications with UIC. He will coordinate the MWRDGC's review of this protocol and QAPPs, the external scientific review, a local stakeholder review, and WERF/Science Advisory Board-UIC meetings. Dr. Granato will ensure the transfer of data collected by the MWRDGC, such as water quality measures monitored along the CAWs, the CSOs, water flow through the controlling works and pumping stations, and effluent discharge from the WRPs.

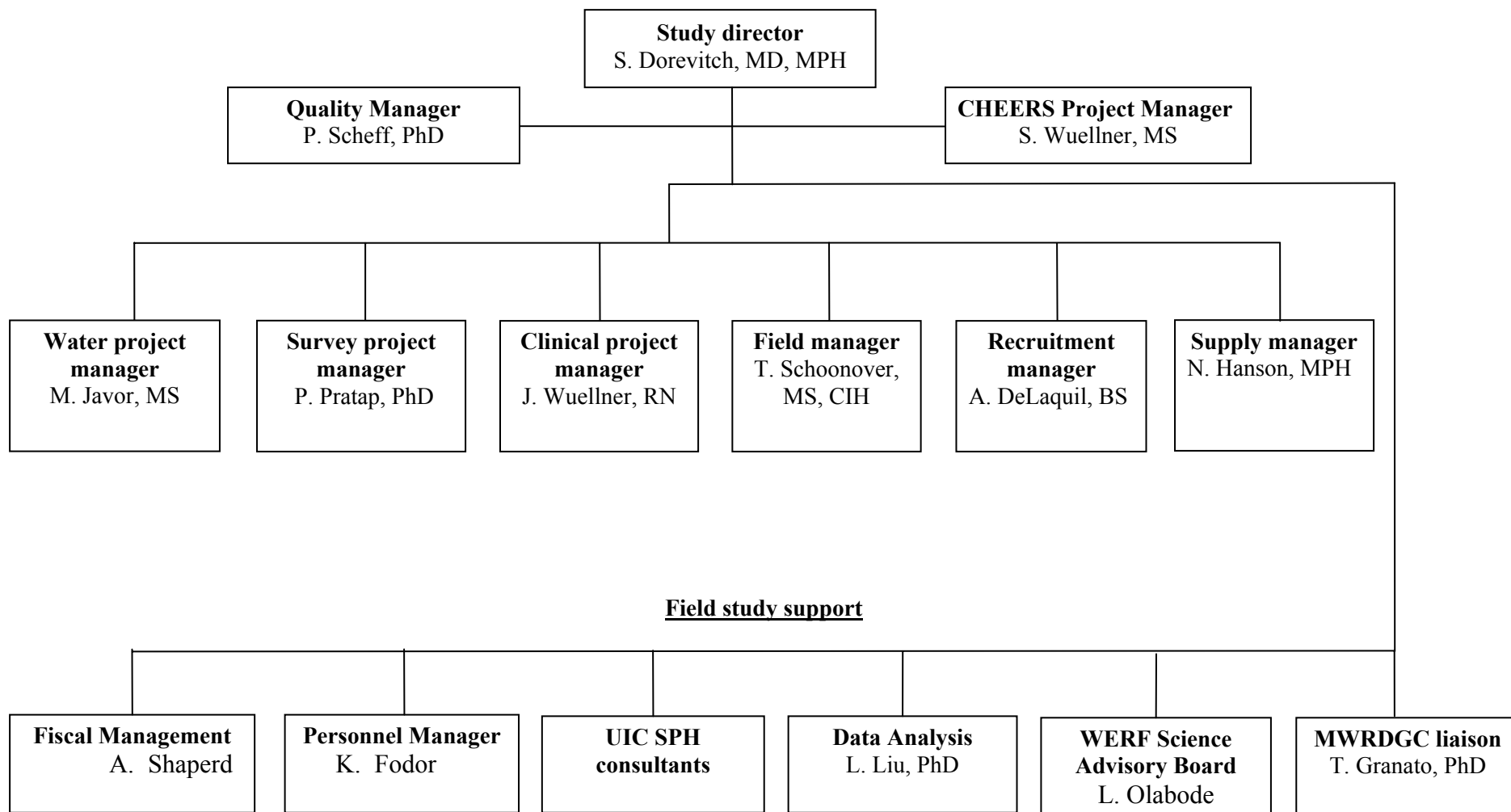

Figure 6: CHEERS project management

## 15. Communications Plan

### 15.1 General

The study director, quality manager, project managers, field manager, and their assistants meet each week to discuss the data quality objectives and any issues or concerns regarding field work and logistics. The study maintains an internal website for sharing documents, housing training materials, and posting schedules. All study managers have access to the website. In addition to this meeting of the core leadership team, “water group” meetings and “interview group” meetings will be held on a weekly basis, with the project coordinator and assistant study directors planning upcoming events and reviewing quality data (such as unusual occurrence reports) with project staff. Communications between the project managers and the project staff is supported by a “Shiftboard” website. That site is used for scheduling and general communications purposes. A central element of the CHEERS training manual includes lines of communications and all personnel are aware of whom to contact with questions.

### 15.2 Field work

Pre-paid cellular phone cards are provided to field supervisors and onsite survey data managers to facilitate field communications and to allow supervisors to coordinate activities and address problems as quickly as possible. Members of the interview/recruitment team bring questions or concerns to the enrollment onsite data manager. In the event that the data managers have questions or concerns, they contact the day’s field interview supervisor. Members of the water sampling team bring concerns to the field water supervisor. Questions from the field supervisors re brought to the project coordinator, who consults with the study director when necessary. All field staff are provided with a list of contact names and phone numbers that includes daily field supervisor and study director contact information, as well as contact information for laboratories and municipalities with which we work. Before each shift, a briefing is conducted by the field supervisor to address any new or ongoing issues.



## References

1. CDM. Use Attainability Analysis (Draft). 2004.
2. Illinois EPA. Pre-filed testimony of Rob Sulski. 2007.
3. CDM. Chicago Area Waterway Use Attainability Analysis. 2007.
4. Fewtrell L, Godfree AF, Jones F, Kay D, Salmon RL, Wyer MD. Health effects of white-water canoeing. *Lancet* 1992; 339:1587-9.
5. Fewtrell L, Kay D, Salmon RL, Wyer MD, Newman G, Bowering G. The health effects of low-contact water activities in fresh and estuarine waters. *Journal of the Institute of Water and Environmental Management* 1994; 81:97-101.
6. Lee JV, Dawson SR, Ward S, Surman SB, Neal KR. Bacteriophages are a better indicator of illness rates than bacteria amongst users of a white water course fed by a lowland river. *Water Sci Technol* 1997; 35:165-70.
7. Gray JJ, Green J, Cunliffe C, Gallimore C, Lee JV, Neal K, et al. Mixed genogroup SRSV infections among a party of canoeists exposed to contaminated recreational water. *J Med Virol* 1997; 52:425-9.
8. Appleton CC, Bailey IW. Canoeists and waterborne diseases in South Africa. *S Afr Med J* 1990; 78:323-6.
9. Taylor MB, Becker PJ, Van Rensburg EJ, Harris BN, Bailey IW, Grabow WO. A serosurvey of water-borne pathogens amongst canoeists in South Africa. *Epidemiol Infect* 1995; 115:299-307.
10. Pruss A. Review of epidemiological studies on health effects from exposure to recreational water. *Int J Epidemiol* 1998; 27:1-9.
11. Wade TJ, Pai N, Eisenberg JN, Colford JM, Jr. Do U.S. Environmental Protection Agency water quality guidelines for recreational waters prevent gastrointestinal illness? A systematic review and meta-analysis. *Environ Health Perspect* 2003; 111:1102-9.
12. Stevenson AH. Studies of bathing water quality and health. *Am J Public Health* 1953; 43:529-38.
13. Cabelli VJ, Dufour AP, Levin MA, McCabe LJ, Haberman PW. Relationship of microbial indicators to health effects at marine bathing beaches. *Am J Public Health* 1979; 69:690-6.

14. Cabelli VJ, Dufour AP, McCabe LJ, Levin MA. Swimming-associated gastroenteritis and water quality. *Am J Epidemiol* 1982; 115:606-16.
15. Dufour AP. Bacterial indicators of recreational water quality. *Can J Public Health* 1984; 75:49-56.
16. Colford JM, Jr., Wade TJ, Schiff KC, Wright CC, Griffith JF, Sandhu SK, et al. Water quality indicators and the risk of illness at beaches with nonpoint sources of fecal contamination. *Epidemiology* 2007; 18:27-35.
17. Wade TJ, Calderon RL, Brenner KP, Sams E, Beach M, Haugland R, et al. High sensitivity of children to swimming-associated gastrointestinal illness: results using a rapid assay of recreational water quality. *Epidemiology* 2008; 19:375-83.
18. Wade TJ, Calderon RL, Sams E, Beach M, Brenner KP, Williams AH, et al. Rapidly measured indicators of recreational water quality are predictive of swimming-associated gastrointestinal illness. *Environ Health Perspect* 2006; 114:24-8.
19. Fleisher JM, Jones F, Kay D, Stanwell-Smith R, Wyer M, Morano R. Water and non-water-related risk factors for gastroenteritis among bathers exposed to sewage-contaminated marine waters. *Int J Epidemiol* 1993; 22:698-708.
20. Fleisher JM, Kay D, Salmon RL, Jones F, Wyer MD, Godfree AF. Marine waters contaminated with domestic sewage: nonenteric illnesses associated with bather exposure in the United Kingdom. *Am J Public Health* 1996; 86:1228-34.
21. Kay D, Fleisher JM, Salmon RL, Jones F, Wyer MD, Godfree AF, et al. Predicting likelihood of gastroenteritis from sea bathing: results from randomised exposure. *Lancet* 1994; 344:905-9.
22. Wiedenmann A, Kruger P, Dietz K, Lopez-Pila JM, Szewzyk R, Botzenhart K. A randomized controlled trial assessing infectious disease risks from bathing in fresh recreational waters in relation to the concentration of *Escherichia coli*, intestinal enterococci, *Clostridium perfringens*, and somatic coliphages. *Environ Health Perspect* 2006; 114:228-36.
23. Jessop EG, Horsley SD, Wood L. Recreational use of inland water and health: are Windermere and Coniston water a health hazard? *Public Health* 1985; 99:338-42.

24. Dziuban EJ, Liang JL, Craun GF, Hill V, Yu PA, Painter J, et al. Surveillance for waterborne disease and outbreaks associated with recreational water--United States, 2003-2004. *MMWR Surveill Summ* 2006; 55:1-30.
25. Yoder JS, Blackburn BG, Craun GF, Hill V, Levy DA, Chen N, et al. Surveillance for waterborne-disease outbreaks associated with recreational water--United States, 2001-2002. *MMWR Surveill Summ* 2004; 53:1-22.
26. MWRDGC. Expert review report regarding United States Environmental Protection Agency's water quality criteria for bacteria - applicaiton to secondary contact criteria. Chicago, IL, 2006.
27. GeosyntechConsultants. Dry and wet weather risk assessment of human health impacts of disinfection versus no disinfection of the Chicago Area Waterways System (CWS). 2008.
28. Dufour AP, Evans O, Behymer TD, Cantu R. Water ingestion during swimming activities in a pool: a pilot study. *J Water Health* 2006; 4:425-30.
29. Black S, Shinefield H, Hansen J, Lewis E, Su L, Coplan P. A post-licensure evaluation of the safety of inactivated hepatitis A vaccine (VAQTA, Merck) in children and adults. *Vaccine* 2004; 22:766-72.
30. Jones F, Kay D, Stanwell-Smith R, Wyer M. Results of the first pilot scale controlled cohort epidemiological observation into the possible health effects of bathing in seawater and Landland Bay, Swansea. *J Inst Water Env Management* 1991:91-8.
31. Mandell G, Bennet J, Dolin R. Principles and Syndromes of Enteric Infections. In: *Principles and Practices of Infectious Diseases* 6ed. Philadelphia, PA: Elsevier Inc.; 2005.
32. Wymer LJ, Dufour AP, Calderon RL, Wade TJ, Beach M. Comment on "Derivation of numerical values for the World Health Organization guidelines for recreational waters". *Water Res* 2005; 39:2774-7.

# **CHEERS Overview Document**

## **Appendix 1: Study Logo**



***CHEERS***

***WATER CHICAGO SPORTS***

# **CHEERS Overview Document**

## **Appendix 2: Recruitment Flier**

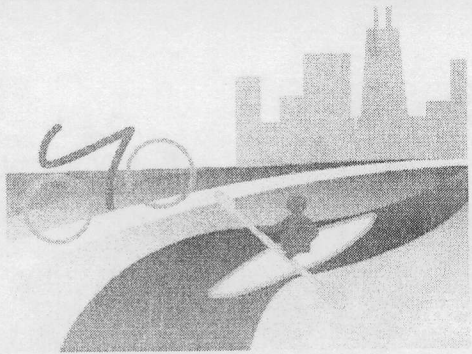

# CHEERS

WATER CHICAGO SPORTS

IRB approval box

STARTS **APPROVAL** EXPIRES

JUN 21 2008 JUN 20 2009

UNIVERSITY OF ILLINOIS AT CHICAGO  
INSTITUTIONAL REVIEW BOARD

**PLEASE NOTE: THE CHEERS STUDY IS IN PROGRESS TODAY AT THE LAKE**

As part of our efforts to improve public health, the University of Illinois at Chicago (UIC) School of Public Health is conducting a three-year study called "CHEERS," The Chicago, Health, Environmental Exposure and Recreation Study. In this study, researchers will evaluate the health of people who exercise outdoors, some who have water contact, and some who do not. This research will take place on different days, at different locations on or near Lake Michigan, the Chicago and Calumet River systems, and other rivers and lagoons in the Chicago area. **If you participate in two short survey interviews today, you will receive a \$15 gift card and a T-shirt today. After completing three 10 minute telephone follow-up interviews over the next three weeks, a check for \$35 check will be mailed to you after your last home telephone interview. If you are selected for a follow-up home visit by research nurses, you will receive a check for an additional \$75.**

**Purpose of the Survey.** Today's survey is part of a research project that will help to better understand the relationship between outdoor recreation, water quality, and, people's health. When the research project is completed, the results will help develop better guidelines for recreational water quality.

**Your Cooperation is Extremely Valuable and Will be Greatly Appreciated.** Of course, your participation in today's survey is voluntary – whether you are interviewed today is entirely up to you. All the information that you provide will be kept confidential.

**What to Expect Today.** All interviewers are wearing CHEERS t-shirts and name badges. If you are eligible, staff will interview you for about 3 minutes. The second part of the interview will be conducted after you finish your outdoor activity today. This will take about 8-10 minutes.

**When you go home.** We will contact you three times over the next three weeks, to ask you about your health. On completion of the last telephone interview, we will send you a \$35 check. If you are selected for a home visit, we may request a stool sample, or research staff may visit you at home. If you were to get sick, those results could help you and your doctor by identifying germs that may have made you ill. You would receive an additional check for \$75 for the home visit.

**Local Support for CHEERS:** Several cities, including Chicago, Evanston, Skokie, Worth, and Alsip are helping UIC with this project. For any questions call the CHEERS project coordinator at (312) 996-2094.

**WE THANK YOU IN ADVANCE FOR YOUR TIME AND COOPERATION!!**

# **CHEERS Overview Document**

## **Appendix 3: Information for clubs, team organizers and vendors**





## General information about CHEERS: For clubs, teams, organizations, and vendors

- CHEERS is the “Chicago Health and Environment Exposure Recreation Study” and it is being conducted by Dr. Sam Dorevitch of The University of Illinois at Chicago (UIC) School of Public Health.
- This study is being funded by the Metropolitan Water Reclamation District of Greater Chicago.
- CHEERS is a research study about the health of people in the Chicago area who participate in outdoor activities. We are interested in canoers, kayakers, rowers and fishermen on waters in the Chicago area, as well as, people engaging in outdoor activities that don’t involve water (such as bicycling and jogging) near local lakes, lagoons and rivers.
- Our goal is to assess the health of people who participate in different outdoor activities on and around local lakes, lagoons, rivers and channels.
- We want to know if health is linked with water quality, especially among people like you who participate in outdoor recreational activities in and around the Chicago waterways.
- The results of this study could be used for developing better environmental water quality standards to improve public health.
- The study does not involve swimmers because many research studies have evaluated the link between water quality and swimming. This study addresses other forms of water recreation.
- No information provided by research participants during the research will be disclosed to non-research staff. We respect the privacy of research participants. All computer files with will be password-protected. When the results of the research are published or discussed in conferences, no information will be included that would reveal the identity of study participants.
- The research study will last about 3 years. Individuals who will enroll will answer a few questions in person when they enroll in the study. We’ll contact them by phone 2, 5 and 21 days from the date of enrollment to check on their health. When they have completed the last telephone interview, 21 days later they will be eligible to partake in the study again.
- We will explain the study to potential participants in detail. Any questions they may have will be answered. Then, we will ask them a few questions to see if they are eligible to be in this study.
- Anyone who participates will be given a free CHEERS T-shirt and a \$15 Target gift card after finishing the surveys. At the end of 21 days of participation we will send participants a \$35 check for their time and effort.
- Some people will be selected for an optional home visit. We will provide those selected with an extra \$75.
- This is not an official recruiting document. Anyone who wants to be in the study will be given a consent form, and we will answer any questions they may have about this research.
- We look forward to the opportunity to work with your organization on this environmental health study! For any questions, please contact Amelia DeLaquil at [adelaquil@gmail.com](mailto:adelaquil@gmail.com).

# **CHEERS Overview Document**

## **Appendix 4: Water Quality Frequently Asked Questions sheet**

## Water Quality Information for the Public



IRB approval box

STARTS **APPROVAL** EXPIRES

JUN 21 2008 JUN 20 2009

UNIVERSITY OF ILLINOIS AT CHICAGO  
INSTITUTIONAL REVIEW BOARD

### The Chicago River and Calumet River system

These river systems are managed by the Metropolitan Water Reclamation District of Greater Chicago. Swimming, jet skiing and water skiing not allowed in these waterways, but activities such as boating, fishing, and rowing are allowed. For more information about the waterways, visit: <http://www.chicagoareawaterways.org/>

For more information about the Metropolitan Water Reclamation District, visit:  
<http://www.mwrldg.dst.il.us/>

### Lakes and Beaches

For more information about beach health and beach closings in Chicago, please visit the website of the Chicago Park District Beach Report  
[http://chicagoparkdistrict.com/index.cfm/fuseaction/index.cfm/fuseaction/swim\\_report.home](http://chicagoparkdistrict.com/index.cfm/fuseaction/index.cfm/fuseaction/swim_report.home)

For more information about beach health, please visit to website of the Illinois Department of Public Health Beach Information  
<http://www.idph.state.il.us/envhealth/beachhome.htm>

For more information about water quality on Lake Michigan, visit the website of the Alliance for the Great Lakes: <http://www.greatlakes.org/>

### Eating fish caught in Illinois rivers and lakes

General information, 2007:  
<http://www.jchdonline.org/jackson/Fish%20Advisory%2002.02.07.pdf>

Great lakes fish: <http://www.great-lakes.net/envt/flora-fauna/wildlife/fishadv.html>





The Chicago River system: <http://www.idph.state.il.us/envhealth/fishadv/chicagoriver.htm>







# **CHEERS Overview Document**

## **Appendix 5**

### **Recruitment sites: CAWS**

**2008 Recruiting Site Specifications-CAWS**

Site	GPS Coordinates	Water Activity					Non-water Activity				Recruitment Area and Tent Location
		Canoeing	Kayaking	Rowing	Powerboating	Fishing	Run/walking	Bicycling	Golfing	Playing ball	
<b>CAWS: Calumet System</b>											
Village of Alsip Boat Launch	N: 41°39.947' W: 87°45.342'				✓	✓					
Village of Worth Boat Launch and adjacent aeration station	N: 41°40.763' W: 87°48.157'  N: 41°40.704' W: 87°47.765'				✓	✓	✓	✓	✓		
Riverdale Marina	N: 41°39.393' W: 87°38.733'				✓	✓					
<b>CAWS: North Branch Chicago River</b>											
North Ave, East	N: 41°54.607' W: 87°93.283'		✓				✓				

North Ave, West	N: 41°54.564' W: 87°39.539'		✓								
Clark Park	N: 41°56.589' W: 87°41.701'	✓	✓			✓	✓				
West River Park/Ronan Park	N: 41°58.426' W: 87°42.286'					✓	✓				
Skokie Rowing Center	N: 42°01.668' W: 87°42.572'	✓	✓	✓			✓	✓			
<b>CAWS: Main Stem</b>											
Columbus & Wacker	N: 41°53.295' W: 87°37.217'					✓	✓	✓			
<b>CAWS: South Branch Chicago River</b>											
Ping Tom Park	N: 41°51.820' W: 87°38.039'	✓	✓	✓			✓	✓			













# **CHEERS Overview Document**



## **Appendix 6**

### **Recruitment sites: G UW**

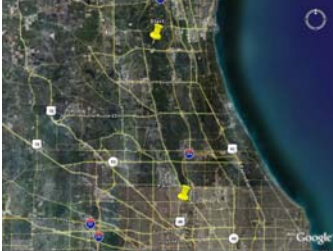

Site	GPS Coordinates	Water Activity					Non-water Activity				Recruitment Area and Tent Location
		Canoeing	Kayaking	Rowing	Powerboating	Fishing	Run/walking	Bicycling	Golfing	Playing ball	
<b>G UW: Lake Michigan</b>											
Belmont Harbor	N: 41°56.475' W: 87°38.230'				✓	✓	✓	✓			
Burnham Harbor	N: 41°51.628' W: 87°36.778'				✓	✓	✓	✓			
Diversey Harbor	N: 41°55.511' W: 87°38.072'				✓		✓	✓			
Jackson Park Harbor	N: 41°46.439' W: 87°34.227'				✓	✓	✓	✓	✓		
Leone Beach	N: 42°0.466' W: 87°39.431'		✓				✓	✓			

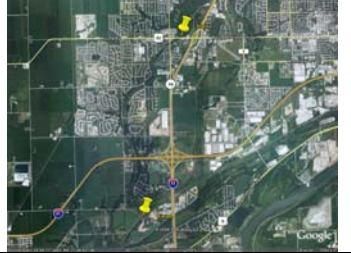
Montrose Harbor/Wilson Beach	N: 41°57.450' W: 87°38.302'		✓		✓	✓	✓	✓	✓	
Solidarity Drive	N: 41°51.995' W: 87°36.593'				✓	✓	✓	✓		
<b>G UW: Area Waterways</b>										
Busse Lake Boating Center	N: 42°01.467' W: 88°00.900'	✓	✓		✓	✓	✓	✓		
Crystal Lake	N: 42°14.107' W: 88°22.170'			✓						
Fox River, St. Charles	N: 41°54.975' W: 88°18.855'			✓			✓	✓		
Des Plaines River, Libertyville – Mt. Prospect	N: 42°17.321' W: 87°56.256'	✓	✓							

Lincoln Park Boat Club	N: 41°55.452' W: 87°37.927'		✓	✓		✓	✓	✓		
Hammel Woods, Shorewood	N: 41°31.353' W: 88°11.647'		✓			✓				
Skokie Lagoons	N:42°07.368' W: 87°46.367'	✓	✓		✓	✓		✓		
Tampier Lake Boating Center	N: 41°39.037' W: 87°53.868'	✓	✓		✓	✓	✓	✓		

# **CHEERS Overview Document**

## **Appendix 7**

### **2007 Recruiting Schedule**

DATE	SITE
8/4/2007	CAWS: Alsip Boat Launch
8/11/2007	G UW: Skokie Lagoons
8/12/2007	CAWS: Skokie Rowing Center
8/17/2007	CAWS: Worth Boat Launch
8/18/2007	G UW: Skokie Lagoons
8/19/2007	CAWS: Skokie Rowing Center
8/24/2007	G UW: Montrose Beach
8/25/2007	G UW: Diversey Harbor
8/26/2007	CAWS: Clark Park
8/31/2007	CAWS: River Park
9/1/2007	G UW: Montrose Beach
9/8/2007	G UW: Leone Beach
9/8/2007	CAWS: Skokie Rowing Center
9/9/2007	CAWS: Skokie Rowing Center
9/9/2007	CAWS: Clark Park
9/15/2007	G UW: Montrose Beach
9/16/2007	CAWS: Clark Park - Ping Tom (Flatwater Classic)
9/22/2007	CAWS: Worth Boat Launch
9/22/2007	CAWS: Alsip Boat Launch
9/23/2007	G UW: Jackson Park Harbor
9/24/2007	CAWS: Skokie Rowing Center
9/29/2007	G UW: Montrose Beach
9/30/2007	G UW: Montrose Beach
10/1/2007	CAWS: Skokie Rowing Center
10/6/2007	G UW: Montrose Beach
10/7/2007	G UW: Jackson Park Harbor
10/9/2007	CAWS: Skokie Rowing Center
10/13/2007	G UW: Montrose Beach
10/14/2007	G UW: Crystal Lake
10/16/2007	G UW: Crystal Lake
10/23/2007	CAWS: North Ave @ Kingsbury
11/5/2007	CAWS: North Ave @ Kingsbury

# **CHEERS Overview Document**

## **Appendix 8**

### **2008 Recruiting Schedule**

Date	Location	Notes
3/10/2008	CAWS: North Ave @ Kingsbury	
3/18/2008	CAWS: North Ave @ Magnolia	
3/22/2008	CAWS: North Ave @ Magnolia	team canceled
3/24/2008	CAWS: Skokie Rowing Center	
3/26/2008	CAWS: North Ave @ Magnolia	
3/31/2008	CAWS: Skokie Rowing Center	
4/1/2008	CAWS: Skokie Rowing Center	
4/5/2008	G UW: Diversey Harbor	
4/7/2008	CAWS: North Ave @ Kingsbury	
4/13/2008	G UW: Diversey Harbor	
4/14/2008	CAWS: North Ave @ Magnolia	
4/19/2008	G UW: DuPage River - Hammel Woods	
4/20/2008	G UW: Skokie Lagoons	
4/21/2008	CAWS: Skokie Rowing Center	
4/22/2008	CAWS: Skokie Rowing Center	
4/23/2008	G UW: Crystal Lake	
4/26/2008	G UW: Diversey Harbor	
4/27/2008	G UW: Upper Des Plaines River	
5/3/2008	G UW: Skokie Lagoons	
5/4/2008	G UW: Montrose Beach	
5/10/2008	G UW: Jackso Park Harbor	
5/11/2008	G UW: Burnham Harbor	rain cancellation
5/12/2008	CAWS: North Ave @ Magnolia	
5/13/2008	CAWS: North Ave @ Magnolia	canceled
5/17/2008	G UW: Skokie Lagoons	
5/18/2008	G UW: Des Plaines River - Libertyville	
5/22/2008	CAWS: North Ave @ Magnolia	
5/22/2008	G UW: Jackso Park Harbor	
5/24/2008	CAWS: Skokie Rowing Center	
5/24/2008	CAWS: River Park	
5/24/2008	CAWS: Clark Park	
5/24/2008	CAWS: North Ave @ Magnolia	
5/25/2008	CAWS: Alsip Boat Launch	
5/25/2008	CAWS: Riverdale Marina	
5/25/2008	CAWS: Worth Boat Launch	
5/26/2008	G UW: Montrose Beach	
5/26/2008	G UW: Diversey Harbor	
5/26/2008	G UW: Jackso Park Harbor	
5/30/2008	CAWS: Alsip Boat Launch	rain cancellation
5/30/2008	CAWS: Riverdale Marina	rain cancellation
5/30/2008	CAWS: Worth Boat Launch	rain cancellation
5/31/2008	G UW: Busse Lake Boating Center	
5/31/2008	G UW: Diversey Harbor	

5/31/2008	G UW: Leone Beach	
5/31/2008	G UW: Montrose Beach	
6/1/2008	G UW: Crystal Lake	
6/1/2008	G UW: Skokie Lagoons	
6/6/2008	CAWS: Clark Park	rain cancellation
6/6/2008	CAWS: Skokie Rowing Center	rain cancellation
6/7/2008	G UW: Fox River - St. Charles	
6/7/2008	G UW: Tampier Lake Boating Center	
6/8/2008	G UW: Busse Lake Boating Center	
6/8/2008	G UW: Fox River - St. Charles	
6/9/2008	CAWS: Skokie Rowing Center	
6/10/2008	CAWS: Skokie Rowing Center	
6/13/2008	CAWS: Alsip Boat Launch	
6/13/2008	CAWS: Riverdale Marina	
6/13/2008	CAWS: Worth Boat Launch	
6/14/2008	G UW: Belmont Harbor	
6/14/2008	G UW: Diversey Harbor	
6/14/2008	G UW: Montrose Beach	
6/14/2008	G UW: Skokie Lagoons	
6/15/2008	CAWS: Clark Park	
6/15/2008	CAWS: North Ave @ Magnolia	
6/15/2008	CAWS: River Park	
6/15/2008	CAWS: Skokie Rowing Center	
6/17/2008	CAWS: North Ave @ Kingsbury	
6/20/2008	CAWS: Alsip Boat Launch	
6/20/2008	CAWS: Riverdale Marina	
6/20/2008	CAWS: Worth Boat Launch	
6/21/2008	CAWS: Clark Park	
6/21/2008	CAWS: Evanston Ecology Center	
6/21/2008	CAWS: North Ave @ Magnolia	
6/21/2008	CAWS: River Park	
6/21/2008	CAWS: Skokie Rowing Center	
6/22/2008	CAWS: Alsip Boat Launch	
6/22/2008	CAWS: Riverdale Marina	
6/22/2008	CAWS: Worth Boat Launch	
6/22/2008	G UW: Tampier Lake Boating Center	
6/27/2008	CAWS: Clark Park	
6/27/2008	CAWS: River Fishing Festival	
6/27/2008	CAWS: Skokie Rowing Center	
6/28/2008	CAWS: Alsip Boat Launch	
6/28/2008	CAWS: Riverdale Marina	
6/28/2008	CAWS: Worth Boat Launch	
6/28/2008	G UW: Busse Lake Boating Center	
6/29/2008	CAWS: Clark Park	
6/29/2008	CAWS: North Ave @ Magnolia	
6/29/2008	CAWS: Skokie Rowing Center	



6/29/2008	G UW: Skokie Lagoons	
7/4/2008	G UW: Burnham Harbor	
7/4/2008	G UW: Leone Beach	
7/4/2008	G UW: Montrose Beach	
7/4/2008	G UW: Solidarity Drive	
7/5/2008	CAWS: Clark Park	
7/5/2008	CAWS: North Ave @ Magnolia	
7/5/2008	CAWS: River Park	
7/5/2008	CAWS: Skokie Rowing Center	
7/5/2008	G UW: Lincoln Park Boat Club	
7/6/2008	CAWS: Alsip Boat Launch	
7/6/2008	CAWS: Riverdale Marina	
7/6/2008	CAWS: Worth Boat Launch	
7/6/2008	G UW: Busse Lake Boating Center	
7/7/2008	CAWS: River Fishing Festival	
7/11/2008	CAWS: Clark Park	
7/11/2008	CAWS: North Ave @ Magnolia	
7/11/2008	CAWS: River Fishing Festival	
7/11/2008	CAWS: Skokie Rowing Center	
7/12/2008	G UW: Lake Arlington	rain cancellation
7/12/2008	G UW: Diversey Harbor	rain cancellation
7/12/2008	G UW: Lincoln Park Boat Club	
7/12/2008	G UW: Montrose Beach	rain cancellation
7/13/2008	CAWS: Clark Park	
7/13/2008	CAWS: North Ave @ Magnolia	
7/13/2008	CAWS: Skokie Rowing Center	
7/13/2008	G UW: Skokie Lagoons	
7/18/2008	G UW: Belmont Harbor	
7/18/2008	G UW: Busse Lake Boating Center	
7/18/2008	G UW: Diversey Harbor	
7/18/2008	G UW: Montrose Beach	
7/19/2008	CAWS: Alsip Boat Launch	rain cancellation
7/19/2008	CAWS: Worth Boat Launch	rain cancellation
7/19/2008	G UW: Tampier Lake Boating Center	rain cancellation
7/20/2008	CAWS: Clark Park	
7/20/2008	CAWS: North Ave @ Magnolia	
7/20/2008	CAWS: River Park	
7/20/2008	CAWS: Skokie Rowing Center	
7/20/2008	G UW: Skokie Lagoons	
7/25/2008	CAWS: Clark Park	
7/25/2008	G UW: Diversey Harbor	
7/25/2008	G UW: Montrose Beach	
7/25/2008	G UW: Solidarity Drive	
7/26/2008	CAWS: Clark Park	
7/26/2008	CAWS: North Ave @ Magnolia	
7/26/2008	CAWS: Ping Tom Park	

7/27/2008 CAWS: Alsip Boat Launch  
7/27/2008 CAWS: Worth Boat Launch  
7/27/2008 G UW: Tampier Lake Boating Center

Overview Appendix 8: 2008 CHEERS recruiting schedule

# **CHEERS: The Chicago Health, Environmental Exposure and Recreation Study**

## **QUALITY MANAGEMENT PLAN**

Samuel Dorevitch, MD, MPH  
Division of Environmental and Occupational Health Sciences  
Division of Epidemiology and Biostatistics  
University of Illinois at Chicago School of Public Health  
2121 W. Taylor, M/C 922  
Chicago, IL 60612

\_\_\_\_\_  
Samuel Dorevitch, Study Director

\_\_\_\_\_  
Date

\_\_\_\_\_  
Peter A. Scheff, Project Quality Manager

\_\_\_\_\_  
Date

## **Table of Contents**

<b><u>Section</u></b>	<b><u>Page</u></b>
I. INTRODUCTION	1
II. MANAGEMENT AND ORGANIZATION	2
III. QUALITY SYSTEM COMPONENTS	11
IV. PERSONNEL QUALIFICATION AND TRAINING	16
V. PROCUREMENT OF ITEMS AND SERVICES	17
VI. DOCUMENTS AND RECORDS	17
VII. COMPUTER HARDWARE AND SOFTWARE	18
VIII. PLANNING	18
IX. IMPLEMENTATION OF WORK PROCESSES	19
X. ASSESSMENT AND RESPONSE	19
XI. QUALITY IMPROVEMENT	20

## **List of Acronyms**

CAWs	Chicago Area Waterways
CDC	Centers for Disease Control and Prevention
CSOs	Combined Sewer Overflows
DQO	Data quality objective
FCR	Friends of the Chicago River
IEPA	Illinois Environmental Protection Agency
IRB	Institutional Review Board
MWRDGC	Metropolitan Water Reclamation District of Greater Chicago
NEEAR	National Environmental and Epidemiological Assessment of Recreational Water
QA	Quality assurance
QAPP	Quality Assurance Project Plan
QC	Quality Control
QM	Quality manager
QMP	Quality Management Plan
SPH	School of Public Health
SRL	Survey Research Laboratory
UAA	Use attainability analysis
UIC	University of Illinois at Chicago
USEPA	United States Environmental Protection Agency
WRP	Water Reclamation Plant

## **INTRODUCTION**

This document was designed to conform with US Environmental Protection Agency (EPA) quality requirements, which are in turn based on ANSI/ASQC E4-1994, *Specifications and Guidelines for Environmental Data Collection and Environmental Technology Programs*. The QMP is designed to conform with EPA Requirements for Quality Management Plans, EPA QA/R-2, which is based upon Part A of the ANSI standard. The QMP provides a system-wide framework for conducting the three projects described in their respective Quality Assurance Projects Plan (QAPP) documents. The QAPPs, in turn are designed to conform with EPA Requirements for Quality Assurance Project Plans, EPA QA/R-5, which is based upon Part B of the ANSI standard. Each QAPP, in turn, is grounded in the principle of obtaining data of sufficient quality and quantity to achieve the objectives of that particular project. Data quality objectives were developed for each project using the EPA's Guidance on Systematic Planning Using the Data Quality Objectives Process, EPA QA/G4.

## **II. MANAGEMENT and ORGANIZATION**

### **1. Organization's policy on quality assurance**

This Quality Management Plan (QMP) describes the systematic approach to addressing quality developed by the UIC team for the conduct of the CAWs epidemiologic study. This QMP documents the management practices, including quality assurance (QA) and quality control (QC) activities, used to ensure that the results of technical work are of the type and quality needed for their intended use. The University of Illinois at Chicago School of Public Health, in general, and this research group in particular, embrace the principles and practices of quality management, recognizing that the data collected for this study are only of value to the degree that they meet quality objectives. The systematic approach to quality is outlined below.

The overall objective of the quality system is to ensure that each of the three component “projects” of the epidemiologic study produce data that will achieve their specific objectives. The quality of data obtained by the three individual projects will be promoted by establishing and implementing organization-wide practices for quality control, personnel training, procurement of supplies and equipment, contracting to extramural entities elements of the study, documentation, data management, work process implementation, assessment, and quality improvement. Furthermore, this will promote a culture of attention to quality and adherence to protocol throughout the organization. It is with the recognition that this research could potentially impact environmental regulation, that we use US EPA quality guidelines to achieve quality objectives.

Resources have been committed to support quality management at both organization and project levels. On the organization level, the salary of the Quality Manager and other staff who perform quality monitoring functions will be supported by this project. Additionally, the directors of each of the three projects and the director of the epidemiologic study will commit a substantial portion of their time addressing quality on organization- and project-levels. Space, resources and personnel will be available for all quality practices needed for data management, record keeping, procurement, and

personnel. Within individual projects, the budget will support all necessary training, documentation, performance evaluations (such as use of field blanks, replicate samples, positive controls, monitoring telephone survey staff), and instruments necessary to monitor and enhance data quality.

## **2. Organization of the research team**

The organizational chart and description of responsibilities are presented in the CHEERS Overview document.

## **3. Authorities of the Quality Manager and other QA staff**

The Quality Manager (QM) will have authority to evaluate quality aspects of all data generating activities. Project Managers will review all quality data with the QM, whether the data were generated by UIC personnel or by subcontractors. The quality manager will be independent of those who generate, compile and evaluate environmental data. The Project Managers, as well as the QC manager of UIC's subcontractors, know that they will be asked to provide quality monitoring data to the UIC QM. Their work with UIC is contingent on their compliance with requests from the QM additional quality data. Likewise, they will be required to respond to quality improvement plans proposed by the UIC QM. QM will have authority to conduct quality audits, review training and documentation practices, and recommend modifications to the study protocols.

## **4. Technical activities supported by the QA system**

### 4.1. Specific programs that require quality management controls

- 4.1.1. Analyses of water samples for *E. coli* and enterococci
- 4.1.2. Analyses of water samples for pathogens and coliphages
- 4.1.3. Participant enrollment and attrition
- 4.1.4. Survey data collection
- 4.1.5. Clinical evaluations of participants
- 4.1.6. Microbiologic evaluations of clinical specimens



- 4.1.7. Data management practices
- 4.2. Oversight of delegated, contracted or other extramural programs needed to assure quality data
- Extramural laboratories will produce data for this study. Those laboratories include:
- 4.2.1. A commercial laboratory that will analyze water samples for *E. coli* and enterococci (described in QAPP #1: Water sampling and analysis).
- 4.2.2. A commercial laboratory that will analyze water filtrate for pathogens and coliphages (described in QAPP #1: Water sampling and analysis).
- 4.2.3. The Illinois Department of Public Health will analyze stool samples for norovirus. (described in QAPP #3: Clinical examinations and microbial evaluations)
- 4.3. Where and how internal coordination of QA and QC activities among the group's organization units needs to occur

Internal QA and QC activities among the organization's units will be coordinated by the QM through regular quality assurance meetings held in room 210 of the UIC SPH West (the CHEERS study center). During the initial weeks of the field study, such meetings will occur following each day of data collection. The frequency of quality assurance meetings will subsequently decrease to once per week if ongoing quality monitoring indicates that data quality objectives are being met. Such meetings will be held during the data collection season only.

At weekly meetings, the QA staff, the study director, the Project Managers, and the Field Manager will review the number of participants enrolled, by site; the number of telephone follow-up calls completed, the number of home visits, the number of positive cultures obtained from clinical specimens. Any problems with equipment calibration or performance will be discussed. Additionally, unusual occurrence reports will reviewed, and results of performance evaluations that did not meet data quality objectives will be discussed. The performance of the system of using notebook computers in the field, and the transfer of data from the field, to the UIC Survey Research Laboratory (SRL), to the telephone call center, and back to SRL will be reviewed.

At monthly reviews, quantitative summaries of water quality data will be presented, as will results of positive clinical specimen cultures, and numbers of participants enrolled by location, by study group. Results of QC data from water and clinical microbiology laboratories will be presented.

Annual reviews are discussed on the following page under “Quality System Components.”

#### **5. Assuring implementation of quality system in all environmental programs**

All management and staff of the epidemiologic study will undergo an orientation session that addresses the importance of the quality system to this research. In that session, either the study director, the project coordinator or the Quality Manager will explain how critical it is that all activities in the study be conducted by protocol. Staff will be encouraged to either contact a manager for help, or to refer to the relevant protocol or operating procedure, rather than “guessing” or improvising about how to handle uncertainty. All Project Managers and assistant project managers will receive a copy of this quality management system. Personnel will be told that quality audits will occur regularly, and that their practices and documentation will be reviewed. By providing timely feedback to study staff about ongoing quality monitoring, a culture of quality will be promoted.

#### **6. Processes for solving disputes**

The QM, rather than the study director, will be final authority for any disputes regarding quality system requirements, procedures, assessments or corrective actions.

### III. QUALITY SYSTEM COMPONENTS

#### 1. Principal components of the system and roles and implementation responsibilities for:

##### 1.1. Documentation

Each project supported by this QMP will have its own QAPP which establishes project-specific documentation requirements. System-wide quality documentation will include reports of weekly project managers' meetings with the QM in attendance, as well as annual summaries of quality monitoring. Copies of the QMP and QAPP will be made available to all study personnel, and will be posted on a secure internal website using UIC's BlackBoard system.

##### 1.2. Annual reviews and planning

Following the completion of data collection for the 2007 water recreation season, data quality will be comprehensively reviewed. Participant recruitment, water sampling and analysis, clinical microbiology results, and survey data, as well as the QC data compiled by internal (UIC) and external laboratories will be reviewed. Results of performance evaluation sample analyses (replicates, field blanks, positive controls), holding times, and other project-specific quality benchmarks will be summarized. Trends and deviations from data quality objectives will be reviewed. Quality improvements for the 2008 water recreation season will be based on the annual quality reviews. The QM and his staff will be responsible for the quality reviews, which will be presented to the study director, the Project Managers, the quality managers of laboratories within and external to UIC, to the study's internal consultants, and to the MWRDGC liaison. In addition to study managers and staff, internal consultants, quality personnel of internal and external laboratories, internal consultants, and the MWRDGC liaison will be invited to participate in the annual reviews.

##### 1.3. Management assessments

For each major data stream (water, survey and clinical), an "Unusual Occurrence Report" will be completed each day of field data collection. Completing the form will be the responsibility of the individual serving as a field data manager (for survey

data), the Field Manager (for water collection data), or the Clinical Project Manager (for clinical microbiology data). The unusual occurrence report will be completed after discussions with each member of the study team at the end of the day. Qualitative information regarding possible deviations from protocol, unexpected events, or problems in documentation, data collection, handling, transport will be recorded. Additionally, Project Managers and the study director will meet with the QM and the study director to identify and address system-wide and project-specific quality problems. They will also participate in annual quality reviews and in quality improvement planning.

#### 1.4. Training

Job descriptions for study positions will define eligibility for hire. Subsequent to hire, additional training will be required. Job descriptions and subsequent training requirements will be developed by the study director, Project Managers, and will be reviewed by the QM.

#### 1.5. Systematic planning of projects

Projects within the larger study have been developed using the EPA “Guidance on systematic planning using the data quality objective process” and the “EPA Requirements for Quality Assurance Project Plans.” Additionally, input has been sought from the MWRDGC, UIC consultants, and environmental researchers external to this project. Additionally, during the design phase of the epidemiologic study, overviews of the research were presented to Mr. Ephraim King of US EPA, Director of the Office of Science and Technology in the Office Water, and his staff; to the Science Advisory Board coordinated by the Water Environment Research Foundation; at an Illinois EPA’s Use Attainability Analysis stakeholder meeting; at a local advisory group on July 9, 2007; at the initial Science Advisory Board meeting (“initial peer review”) organized by WERF on July 17-18, 2007; and at a follow-up Science Advisory Board meeting on February, 27, 2008.

## 1.6. Project-specific quality documentation

Each QAPP supported by this Quality Management Plan includes documentation requirements. Accurate and secure documentation is necessary to ensure the validity, accuracy, precision, and integrity of the data. Each Project Manager will be responsible for ensuring compliance with documentation requirements of their projects. Documentation requirements common to all projects will include chain of custody documentation, storage of the results of laboratory analyses, and ensuring the confidentiality of study participants. The QM will be responsible for regularly reviewing compliance with documentation and other requirements of each project. .

## 1.7. Project and data assessments

All projects, as well as the study overall will be the subject of weekly, monthly and annual assessments. The comparison of actual data quality to data quality objectives will be assessed at these evaluations.

## 2. Tools for implementing each component of the quality system

2.1. This system-wide Quality Management Plan will be the basis for establishing and reviewing quality management practices throughout each project within the larger epidemiologic study.

## 2.2. Audits

2.2.1. Quality system audits will be performed by the QM and the project coordinator. These audits will include qualitative evaluations of the field and laboratory quality control systems. During the system audit, the quality control activities actually performed or scheduled will be compared with those specified in the three

2.2.2. QAPPs. The results of the system audits will include the reviews of the following:

- Completeness of the field records,
- Completeness of the Chain-of-Custodian forms,
- Safe storage the documents and backup of the computer files,
- Adherence to training requirements
- Instrument status and calibration records,
- The status of other relevant laboratory equipment,
- Identification of invalid data based on the specified accuracy, precision, and comparability,
- Any corrective actions and the results.

#### 2.2.2. Performance Audits

A performance audit is a quantitative evaluation of the data collection and analysis aspects of the project. For the projects involving microbial analyses of water samples and microbial analyses of clinical specimens, data from performance evaluation samples (such as replicates, blanks, and positive control or spike samples) will be analyzed. For survey data, “mock subjects” will be enrolled in the study and will provide pre-determined answers to specific questions, and the way such responses are recorded by survey staff will be reviewed. The results will be used to evaluate the performance of the data generation system.

#### 2.3. Training plans

The training plans for staff will be reviewed by the QM. Documentation of the implementation of training within the overall study will be reviewed by the QM. Any deficits in training will be identified and brought to the attention of the Quality Manager and the appropriate Project Manager.

## 2.4. QA Project Plans

One QAPP has been developed for each of the following major study elements:

- Water sampling and analysis
- Survey methods
- Clinical examinations and microbiologic evaluations

These QAPPs will describe project management, data generation and acquisition, assessment and oversight, and data validation and usability. The key function of each QAPP is to ensure that data quality and quantity generated within each project will be sufficient to meet study objectives. Each Project Manager will be responsible for ensuring implementation of the QAPP specific to their project. The QA manager will review each QAPP, and conduct the necessary reviews to ensure that data quality objectives for each QAPP are being met.

## 2.5. Data verification and validation

Each QAPP includes plans to ensure data verification and validation. The Project Managers and quality management staff will review all data generated or acquired to determine if validation rules have been violated, and if so, to identify factors that may have resulted in invalid data. Corrective actions will then be identified by the Quality Manager in conjunction with the Project Manager and project coordinator.

## 3. Components of the organization that develop Quality Plans

Project Managers, the study director, and the QM develop quality plans, in collaboration with quality managers of internal and extramural laboratories that will provide services to the study.

#### **IV. PERSONNEL QUALIFICATIONS AND TRAINING**

##### **1. Policy regarding training for management and staff**

All personnel performing work for the Epidemiologic Study of Recreational Use of the Chicago Area Waterways study will be qualified for all assigned tasks and will be given appropriate training to ensure proper performance of all duties.

##### **2. Processes for ensuring appropriate qualifications and training**

All personnel must be qualified for the roles they will perform in this study. Each role in the project will have a job description that will include the necessary knowledge, skill, certification, accreditation, licenses or other formal qualification. These job descriptions will be developed for project staff by each Project Manager for their personnel. Job descriptions for personnel for whom more than one Project Manager will have authority, will be developed by the relevant Project Managers. Job descriptions for managers in this project will be developed by the study director. Job descriptions will be developed using a template that will include the necessary knowledge, skills, and certification. In addition to the skills required for hire in a position, a list of training requirements for each role in the project will specify the necessary training following hire.

##### **3. Retraining needs**

Project specific training requirements for all CHEERS staff is outlined in the individual QAPPS. Retraining will be required for staff that, on performance evaluations are deficient. The performance evaluations will vary from project to project. For the survey project (QAPP 2) this will involve mock interviews and interview monitoring. For the water sampling and analysis project (QAPP 1) this will involve evaluations of split samples and observations of sampling technique. For the clinical evaluations, it will involve classifying photos of conjunctivitis by severity grade. For all projects, problems



noted on unusual occurrence reports (such as breaches in protocol, chain of custody problems, etc) either retraining or disciplinary action or both will be initiated.

## **V. PROCUREMENT OF ITEMS AND SERVICES**

In order to ensure high quality data, the projects with the epidemiologic study will procure items and services after determining whether performance standards or certifications exist for a particular purchase that are relevant to data quality. We have:

- selected EPA certified laboratories to conduct water analysis
- selected clinical laboratories that are CLIA-certified
- selected equipment such as GPS devices, bar-code scanners, instruments to measure basic water quality parameters after reviewing EPA and other Federal guidelines.
- evaluated tablet and laptop computers to be used in the field surveys will be tested during the pilot study. We will assess battery life, screen visibility in bright outdoor light, field performance, including portability and ease of use
- field tested the bar-code printing and reading technology

## **VI. DOCUMENTS AND RECORDS**

Study-wide we have a uniform that requires appropriate storage of documents. Each QAPP has listed the personnel responsible for the development, storage and distribution of project specific documents and records. For example, consent form that will have Case IDs and names of study participants will require special storage and restricted access. In general paper-based records will have more than 1 copy that will be stored in binders in two different places. We will maintain copies of documents that are free of personal identifiers and raw data in the CHEERS study center (room 210, UIC SPHW). This would include protocols, references, literature, and quality monitoring reports. Paper-based data will be kept in a locked study storage room (room 417, UIC SPHW) and a second copy will be maintained in the office of the manager of the project that generated the data. We will use the UIC Blackboard system which insures multiple CHEERS staff

members can work with, or discuss, the same version of a document at the same time. All computer files with identifiers will be password protected. All computer files, databases, reports will be backed up on a secure UIC server.

## **VII. COMPUTER HARDWARE AND SOFTWARE**

The University of Illinois, Chicago (UIC) has selected high quality hardware from reputable manufactures that we will purchase centrally through the UIC system. Software used for data analysis, the SAS system, has been extensively tested and is widely used in environmental and epidemiologic research conducted by and for the US EPA.

## **VIII. PLANNING**

The initial planning for this project began in February, 2007 when MWDGC personnel and UIC faculty first communicated about this study. The initial weeks of planning involved defining study objectives and selecting an appropriate study design to meet those objectives. Over the subsequent weeks, in consultation with MWRDG personnel, UIC faculty and staff, and external resources, the specific projects of the study were developed. Planning of individual projects used the EPA's systematic planning process called the Data Quality Objectives (DQO) Process mentioned in the *EPA Guidance for the Data Quality Objectives Process (QA/G-4)* (EPA 2000).

The study objectives, study sites, study timetable are presented in the "Overview" document, as are considerations that went into the design of the study.

## **IX. IMPLEMENTATION OF WORK PROCESSES**

The QM and each Project Manager will be responsible for ensuring implementation of the QAPP as written. After new personnel are trained, the Project Managers will supervise their field activities and monitoring adherence to protocol. The QM will review QC data that will identify possible breaches in adherence to protocol, or needs to modify the protocol. Each Project Manager, with QM have identified processes within each project that will require review. Any modification to the protocol will require the approval of the study director and quality manager, as well the notification of the MWRDGC liaison.

## **X. ASSESSMENT AND RESPONSE**

Project specific assessment plans and response actions are outlined in the individual QAPPS. In addition, Section III discusses the overall quality system components including audits and response actions for each QAPP. In addition, any unusual occurrence report will be submitted by the responsible Project Manager to the QM within 24 hours. These reports will be reviewed and an appropriate response action will be decided by the QM and/or the study director.

At weekly meetings, the QA staff, the study director, the Project Managers, and the field coordinator will review any problems with equipment calibration or performance, unusual occurrence reports, and results of performance evaluations that did not meet data quality objectives will be discussed.

At monthly reviews, quantitative summaries of water quality data will be presented, as will results of positive clinical specimen cultures, and numbers of participants enrolled by location, by recreational group. Results of QC data from water and clinical microbiology laboratories will be presented. All available study personnel and will be present at monthly reviews.

Annual reviews are discussed in Section III.

## **XI. QUALITY IMPROVEMENT**

The QM and each Project Manager and program manager will be responsible for identifying, planning, implementing, and evaluating the effectiveness of quality improvement activities as described in each QAPP. At all quality reviews, potential threats to data quality will be identified and addressed. The range of responses will be determined and efforts will be made to improve quality through system-wide improvements. Thus, a quality issue identified in the water project may prompt improvements in that project, and also in the survey or clinical evaluation project.

# CHEERS: THE CHICAGO HEALTH, ENVIRONMENTAL EXPOSURE, AND RECREATION STUDY

## Quality Assurance Project Plan 1: Water Sampling and Analysis

### Title and Approval Sheet

July 29, 2008

University of Illinois at Chicago School of Public Health  
Division of Environmental and Occupational Health Sciences  
Division of Epidemiology and Biostatistics  
2121 W. Taylor, M/C 922  
Chicago, IL 60612

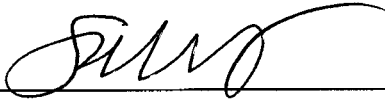
  
\_\_\_\_\_  
Samuel Dorevitch, Study Director

7/30/08  
Date

  
\_\_\_\_\_  
Peter A. Scheff, Quality Manager

7/29/08  
Date

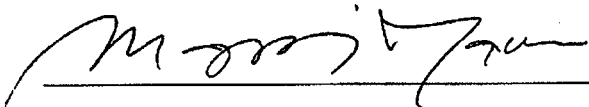
  
\_\_\_\_\_  
Margit Javor, Water Project Manager

7/30/08  
Date

## **Table of Contents**

### **A. PROJECT MANAGEMENT**

1. Distribution List	1
2. Project/Task Organization	1
3. Problem Definition/Background	4
4. Project Task/Description	5
5. Quality Objectives and Criteria	13
6. Special Training/Certification	22
7. Documents and Records	23

### **B. DATA GENERATION AND ACQUISITION**

1. Sampling Process Design (Experimental Design)	24
2. Sampling Methods	25
3. Sample Handling and Custody	33
4. Analytical Methods	35
5. Quality Control	38
6. Instrument/Equipment Testing, Inspection, and Maintenance	40
7. Instrument/Equipment Calibration and Frequency	40
8. Inspection/Acceptance of Supplies and Consumables	41
9. Non-direct Measurements	43
10. Data Management	44

### **C. ASSESSMENT AND OVERSIGHT**

1. Assessments and Response Actions	44
-------------------------------------	----

### **D. DATA VALIDATION AND USABILITY**

1. Data Review, Verification, and Validation	45
2. Verification and Validation Methods	45

### **References**

## List of Tables

Table	Description	Page
Table 1	Contact information for water sampling project	2
Table 2	List of microbes and their quantifying methods	6
Table 3	Summary of sample collection on days of participant enrollment for two years of data collection	8
Table 4	Spike levels, by location	14
Table 5	Summary table for QA/QC Requirements for methods 1600 and 1603 (Enterococci & E.coli)	15
Table 6	Summary table for QA/QC Requirements for method 1602: Male-specific (F+) and Somatic Coliphage in water	16
Table 7	Summary table for QA/QC Requirements for method 1623: Cryptosporidium and Giardia	20
Table 8	Locations of water sampling by participant enrollment site; CAWS sites	25
Table 9	Size of direct sampling bottles	26
Table 10	Suggested range of sample volumes (mL) for fecal coliform tests using the membrane Filter Method	36
Table 11	Dilution volumes, by sampling location, weather condition, and indicator	37
Table 12	Microbiology lab equipment monitoring	41
Table 13	Quality of reagent water used for microbiology testing	42

## List of Figures

Figure	Description	Page
Figure 1	Water sampling organization	1

## List of Appendices

<u>Appendix</u>	<u>Description</u>
1	Laboratory certification, EnviroTest/Perry
2	Laboratory certification, SMI
3	EPA reference method 1603; <i>E. coli</i> in water by membrane filtration
4	EPA reference method 1600; Enterococci in Water by Membrane Filtration
5	EPA reference method 1602; Male-specific (F+) and Somatic Coliphage in Water by Single Agar Layer (SAL) Procedure
6	Method for serotyping F(+)RNA coliphages (Hsu, 1995)
7	EPA's Reference Method 1623 ( <i>Cryptosporidium</i> , <i>Giardia</i> )
8	Method for detection of Norovirus
9	Properties of continuous fluid centrifugation (Zuckerman 2006)
10	EPA approval of CFC for Method 1623
11	Matrix spiking materials
12	Water Quality Sampling Field Data Sheets (FDS)
13	Field Log Book
14	Continuous flow centrifugation (CFC) system
15	SMI Virus sampling kit
16	SMI SOP for CFC
17	Chain-of-Custody records (EnviroTest/Perry)
18	Chain-of-Custody records (SMI)
19	Water sampling location codes



## A. PROJECT MANGAMENT

### 1. Distribution list

Current and revised versions of the Water Sampling and Analysis QAPP are to be distributed to the following individuals:

- i. Samuel Dorevitch, UIC
- ii. Peter Scheff, UIC
- iii. Margit Javor, UIC
- iv. Sara Wuellner, UIC
- v. Todd Schoonover, UIC
- vi. Thomas Granato, MWRDGC

### 2. Project/Task Organization

Key personnel participating in the water sampling and analysis for the epidemiology study and their specific roles/responsibilities are listed below. The organization chart indicating the lines of communication is included in Figure 1.

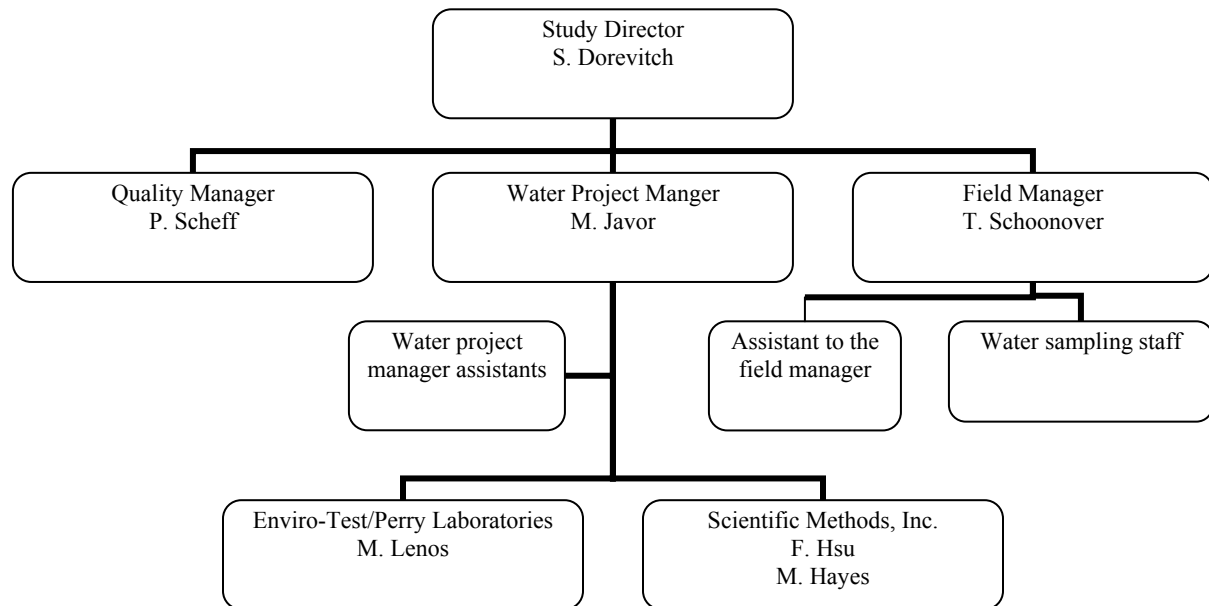

**Figure 1: Water sampling organization**

Name	Project Title or Role	Telephone Number
Samuel Dorevitch	Study Director	(312) 355-3629
Peter Scheff	Quality Manager	(312) 996-0800
Margit Javor	Water Project Manager	(312) 413-1390
Todd Schoonover	Field Manager	(312) 413-0305
Mirka Lenos	Enviro-Test/Perry Lab contact	(630) 734-9530
Fu-Chih Hsu	Scientific Methods, Inc.	(574) 277-4078
Matt Hayes	Scientific Methods, Inc.	(574) 277-4078

**Table 1: Contact information for water sampling project**

#### Responsibilities

##### 1. Study Director: Samuel Dorevitch, MD, MPH

The Study Director will have overall responsibility for the development and implementation of the CHEERS study, as well as providing deliverables to the MWRDGC. Specific responsibilities of the Study Director include the hiring of project staff, establishing subcontracts with entities external to UIC, complying with human subject research protection requirements, and communicating with the MWRDGC and with the public as needed.

##### 2. Water Project Manager: Margit Javor, MS

The Water Project Manager will be responsible for developing the water sampling protocol and selecting, based on performance data, laboratories that will analyze water samples. The Water Project Manager will work with the Field Manager to ensure implementation of protocols and will also be responsible for developing training materials, observing field sampling as needed, and monitoring the field sampling procedures. If deviations from the data quality objectives for water analysis are noted, the Water Project Manager will collaborate with the Quality Manager and Field Manager to identify field practices or protocol elements responsible for such deviations and to develop solutions.

### 3. Quality Manager: Peter Scheff, PhD

The responsibilities of the Study Quality Manager will include assisting with the development of the Quality Assurance Project Plan (QAPP), establishing data quality objectives, reviewing the quality control data of laboratories conducting water analyses, conducting quality audits, and communicating with laboratory Quality Managers.

### 4. Field Manager: Todd Schoonover, MS, CIH, CSP

The responsibilities of the Field Manager will include field training of water samplers, oversight of the surface-water collection, and ensuring that sampling occurs according to written standard operating procedures by trained personnel. The Field Manager will plan and prepare paperwork for each field sampling event and ensure that samples arrive at the lab within the holding-time specified in the relevant analytic methods. The Field Manager will provide updated information to the commercial laboratories regarding the water sampling schedule, including the anticipated number of samples for each analytic method and the expected date and time of sample receipt.

### 5. Commercial Water Quality Laboratory for indicator bacteria: Enviro-Test/Perry Laboratory (contact: Mirka Lenos).

This commercial water quality laboratory will perform analyses of the water samples for *E. coli* and enterococci. The laboratory will be responsible for adhering to US EPA protocols and maintaining Illinois Department of Public Health certification (Appendix 1) as an analytic laboratory for microbial water quality in drinking water. The laboratory will provide results of microbial water quality measures to the Water Project Manager and invoices to the Fiscal Manager.

### 6. Commercial Water Quality Laboratory for pathogens and coliphages: Scientific Methods Incorporated (SMI)

#### 6.1 Laboratory and technical issues (contact: Fu-Chih Hsu, PhD)

Dr. Hsu will be responsible for maintaining Indiana State Department of Health laboratory certification (Appendix 2). He will also be responsible for teaching the Water Project Manager

and the Field Manager to operate the continuous fluid centrifugation (CFC) and virus sampling systems, and also for water pathogen and coliphage analyses conducted by SMI. He will provide results of microbial water quality measures and of internal QC analyses to the Water Project Manager.

#### 6.2 Coordination of sample receiving and reporting of results (contact: Matt Hayes)

Mr. Hayes will prepare for laboratory analyses based on the schedule received by the Field Manager. Mr. Hayes will send laboratory results to the Water Project Manager and invoices to the Fiscal Manager.

### 7. Water sampling staff

#### 7.1 Water Sampling Specialists

Water Sampling Specialists will be responsible for implementing matrix spike sampling on an ongoing basis. This function may also be performed by the Field Manager or by personnel with responsibility for filtration sampling. Water Sampling Specialists will also maintain and use instruments for measuring water chemistry parameters, such as dissolved oxygen, pH, conductivity, turbidity, and temperature.

#### 7.2 Water Sampling Technicians

Water Sampling Technicians will be responsible for collecting samples in accordance with SOPs and documenting any deviations from the SOPs.

### **3. Problem Definition/Background**

The primary purpose of the research study's water sampling activities is to provide a measure of concentration of microbes in the water to which study participants may be exposed. By collecting water samples at the approximate times and locations of water recreation, we aim to identify and characterize water quality measures that predict the risk of illness among people engaging in secondary contact water recreational activities. Samples will be analyzed both for conventional indicators of water quality, as well as for pathogens that may cause recreational waterborne illness.

Concentrations of *Escherichia coli* and enterococci are commonly used as indicators of water quality and samples will be collected and analyzed for these bacteria as part of the study. However, there are limits to the information gained from measurements of *E. coli* and enterococci. First, recreational waterborne illness is not thought to be caused by enterococci and is rarely caused by specific pathogenic strains of *E. coli*. Rather, disease is caused by pathogens such as enteric viruses *Giardia spp.* and *Cryptosporidium spp.*, and bacteria such as *Salmonella spp.*, *Shigella spp.*, and *Aeromonas spp.* Second, the CAWS risk assessment (1) found that bacterial indicators and pathogens were, at best, weakly associated with one another. In one of the few epidemiologic studies of paddlers, measures of coliphages were shown to be better predictors of acute illness than were bacterial indicators.(2) Additionally, coliphage typing allows the tracking of sources of fecal contamination and the differentiation of human from non-human sources of water microbes.(3, 4) To characterize exposure, we will collect water samples throughout each day of participant enrollment at various locations using EPA-approved methods to analyze for indicator bacteria, coliphages, and waterborne pathogens. Samples taken using filtration methods will be archived (frozen) for possible future analyses that can provide a molecular link between pathogens obtained from clinical and water samples.

#### **4. Project/Task Description**

##### 4.1 Overview of water sampling

As discussed in the “Overview” document, the objective of the water sampling is to provide accurate and precise measures of microbe concentrations in the CAWS and general-use waterways (GUW) to address study objectives 2 and 3. In order to characterize the relationship between recreator illness and microbe concentrations in the CAWS (study objective 2), it is necessary to estimate exposure to waterborne microbes among recreators. This will be accomplished by analyzing water samples collected along the waterways at multiple time points throughout the day of participant enrollment. To meet study objective 3 (identifying pathogens responsible for illness and exploring their sources on the CAWS), we will measure three pathogens; *Giardia*, *Cryptosporidium*, and norovirus. Potential future analyses of archived water samples collected upstream and downstream of WRPs may permit testing water samples for specific pathogens (at a species or genotype level) responsible for acute infections among

recreators. Moreover, if a water quality standard were to be applied to the CAWS, compliance with such a standard may require sampling water at specific fixed locations. The results of spatial and temporal variability of water quality on the CAWS, to be established by intensive sampling on a limited number of occasions and by ongoing “standard” sampling during participant enrollment, will provide information that could be translated into regulatory requirements.

Two categories of microbial analyses will be performed: 1) those for indicator microbes and 2) those for pathogens. Samples will be collected by the direct method for indicator bacteria, *E. coli* and enterococci, as well as for male-specific and somatic coliphages. Coliphages will be serotyped (Groups I-IV) to identify the relative contribution of human and non-human sources of coliform bacteria at various locations along the waterways. Pathogen analyses will be performed on samples collected using continuous flow centrifugation (CFC) and with a viral sampling kit. The pathogens to be analyzed are: *Giardia* spp., *Cryptosporidium* spp., and norovirus. In 2007, samples were also analyzed for *Pseudomonas* spp., *Salmonella* spp., and *Shigella* spp. This was discontinued in 2008 based on questions about the precision, accuracy and validity of the 2007 analyses of these bacteria. Following discussions with the CHEERS Science Advisory Board in February 2008, large volume sampling for these pathogens was discontinued. The pairing of indicator and pathogen sampling will build on the risk assessment’s analysis of the relationship between these two categories of microbes on the CAWS.

<b>Microbe</b>	<b>Method</b>	<b>Appendix</b>
<b>Indicators</b>		
E. coli	EPA 1603	Appendix 3
enterococci	EPA 1600	Appendix 4
Male specific coliphage	EPA 1602	Appendix 5
Male specific RNA coliphage serotyping	Hsu, 1995	Appendix 6
<b>Pathogens</b>		
Giardia	EPA 1623	Appendix 7
Cryptosporidium	EPA 1623	Appendix 7
Norovirus	RT-PCR	Appendix 8
Pseudomonas	SM 9213E	discontinued after 2007
Salmonella	EPA 1682	discontinued after 2007
Shigella	SM 9260E	discontinued after 2007

**Table 2. List of microbes and their quantifying methods**

Water sampling will occur at two categories of locations; Access points and WRP-oriented locations. Access points are the locations at which water recreators (research subjects) begin their water recreation. For boaters, paddlers and rowers, this is the “put in” or launch location. For streamside fishers, the access point is where they are fishing. Access point sampling will take place on the CAWS and general use waters. WRP-oriented sampling will take place upstream and downstream of the WRPs. This will occur at CAWS locations only.

Table 3 provides an overview of the sampling schedule for indicators and pathogens at access points and at WRP-related sites on the CAWS, and at general use access points. The differences between 2007 and 2008 sampling strategies are described below.

In addition to microbial evaluations, environmental observations and water chemistry measures will be recorded, as described below (Sections B 2.3 and B 2.4).

Location	<u>2007</u>		<u>2008</u>	
	Indicator sampling	Pathogen sampling	Indicator sampling	Pathogen sampling
<u>CAWS</u>				
Access point	5 every 2 hrs	1-2 per 6-hr day	1 every 2 hrs	1-2 per 12-hr
WRP: Upstream	2 per 6-hr day	1-2 per 6-hr day	2 per 12-hr day	1-2 per 12-hr
WRP: Downstream	2 per 6-hr day	1-2 per 6-hr day	2 per 12-hr day	1-2 per 12-hr
<u>General Use</u>				
River access point	Not done	Not done	3 every 2 hrs	1-2 per 12-hr
Lake/lagoon access	5 every 2 hrs	1-2 per 6-hr day	2 every 2 hrs	1-2 per 12-hr

**Table 3. Summary of sample collection on days of participant enrollment for two years of data collection**

#### 4.2 Frequency and location of water sampling

An overview of sampling intensity (number of samples per round, frequency of sampling) is presented in Table 3, which contrasts the 2008 methods and those employed in 2007.

##### 4.2.1 CAWS sampling

4.2.1.1 Access points: Number of samples collected by direct method for indicator microbes.

During the 2007 enrollment season, samples were collected at 5 points near each access point: left, right, and center stream at the access point plus center stream 0.5 mile upstream and center stream 0.5 mile downstream of the access point. The results of “Preliminary Water Sampling Study 2: Spatial and temporal variability of CAWS indicator organisms” (described in detail in the July, 2007 QAPP: Water Sampling and Analysis), suggested that sampling at one cross-sectional location is sufficient to characterize concentrations across the waterway. Analyses of



the entire 2007 dataset demonstrated that concentrations of all indicator microbes were statistically indistinguishable whether collected at left, center or right sampling sites across cross-sections of CAWS locations. After discussion with the CHEERS Science Advisory Board in February, 2008, sampling was revised to collecting two samples per single cross-sectional location (left, center or right) at each time point of sampling. Analysis of the 2007 data also suggests that, for most locations, concentrations do not differ significantly within a mile of each other along the length of the waterway with one exception; The Skokie Rowing Center, which is immediately upstream of the North Side WRP. With the exception of the Skokie Rowing Center site, the upstream and downstream sampling points were omitted from the 2008 sampling strategy. This allowed us to refine our sampling strategy for the 2008 season and collect samples from a single cross-section at the access point, using a telescopic pole with a sample collection cup secured to the end of the pole. Since the 2007 data suggest that concentrations may vary by time of day, we will continue collecting samples at the access point every two hours.

#### 4.2.1.2 CAWS Sampling: Water reclamation plant-oriented sampling

Samples will be collected once during each 6-hour shift of fieldwork at locations upstream and downstream of the nearest upstream WRP. Because results from the preliminary water study examining the spatial and temporal variability of the indicator organisms in the CAWS showed no statistically significant differences in river cross-sectional concentrations of the indicator microbes, access point samples will be collected from a single cross-sectional location.

#### 4.2.1.3 CAWS Sampling: Large volume sampling for pathogens

Large volume sampling for pathogens will be performed by two methods: continuous flow centrifugation (CFC) and viral filtration sampling. Large volume water samples will be collected at the access point, as well as upstream and downstream of the nearest upstream WRP. These samples will be collected from the cross-sectional location used for recreator access at access points. At WRP-oriented sampling locations, these samples will be collected at either the left-stream or right-stream shore, depending on logistical considerations. Pathogen samples will be collected at each of these three points at least once each day of CAWS participant enrollment.

Three options for the collection of water samples for filtration during the 2008 season were identified: A) Bringing the CFC into the field to sample the water directly from the shore of the river, B) Pumping water into a 20L cubitainer to be brought back to the UIC water quality lab

and processed by the CFC, and C) transporting the cubitainer to the analytic laboratory, approximately 100 miles away, for CFC processing and analysis. Option A was not viable because there were not enough CFC available for use at multiple field locations. After discussing these options with the Scientific Advisory Board, it was decided that during the 2008 season, water would be collected in a 20L cubitainer and brought back to the UIC Water lab for processing in the CFC.

#### 4.2.2 Sampling at general-use waters

Water will be sampled every two hours at access points using a telescopic pole. There will be no WRP-oriented samples as there are no water reclamation plants operating on these waterways. At lake and lagoon locations, two samples will be collected every two hours by telescopic pole from shore. Large volume water samples for pathogens will be collected at access points at least once each day of general use participant enrollment. When possible, a second set of pathogen samples will be collected 6-12 hours later.

The exact locations of water sampling, with GPS coordinates, are found in the Overview document.

### 4.3 Water analysis

#### 4.3.1 Grab samples

##### 4.3.1.1 Analysis for *E. coli*

*Escherichia coli* will be analyzed at the commercial laboratory using US EPA Method 1603, a single-step membrane filter procedure which uses the modified membrane-Thermotolerant *E. coli* (mTEC) agar. The red or magenta colonies that grow on the surface of the membrane filter, after a two-stage incubation period, provide a direct count of *E. coli* in water. The EPA reference method for *E. coli* analyses can be found in Appendix 3 of this QAPP document.

##### 4.3.1.2 Analysis for enterococci

Enterococci indicator bacteria will be analyzed at the commercial laboratory using US EPA Method 1600, a single-step membrane filter procedure which uses the membrane-Enterococcus Indoxyl-b-D-Glucoside (mEI) Agar. All colonies greater than or equal to 0.5mm in diameter with a blue halo are counted in the surface water samples. The EPA reference method for enterococci analyses can be found in Appendix 4 of this QAPP document.

#### 4.3.1.3 Analysis for coliphage

Male-specific (F+) and somatic coliphages will be analyzed at the commercial laboratory using US EPA Method 1602, a single agar layer procedure in which magnesium chloride, log-phase host bacteria, and molten tryptic soy agar are added to the sample. Circular lysis zones (plaques) are counted after an overnight incubation period, allowing for enumeration of coliphage in water. The EPA reference method for coliphage analyses can be found in Appendix 5 of this QAPP document. Serotyping of F(+) RNA coliphages will be performed according to the method of Hsu 1995, which can be found in Appendix 6 of this QAPP document.

#### 4.3.2 Large volume sampling for pathogens

Large volume sampling methods will be used to collect samples for analysis of pathogens. Continuous flow centrifugation (CFC) will be used to collect samples for detection of *Giardia spp.* and *Cryptosporidium spp.* The performance of this method has been previously reported to yield good recoveries (Zuckerman 2006), as detailed in Appendix 9. CFC sampling has received US EPA approval for use (Appendix 10). In 2007 this method was also used for *Shigella spp.*, *Salmonella spp.*, and *Pseudomonas*. The CFC system allows for automated sampling of large volumes by drawing water through an inlet tube using a peristaltic pump at a specified sample flow rate. As the sampled water passes through the continuous flow centrifuge, the pathogens are concentrated in the CFC bowl. We compared two methods of sampling large volumes of water, and the CFC system was chosen as the preferred method of pathogen sampling because of its ease of use in the field and because it is an EPA approved method for *Cryptosporidium* (see appendix 10). A second filtering system will be used to collect water samples for analysis of norovirus and potentially other waterborne viruses.

##### 4.3.2.1 Analysis for *Cryptosporidium* and *Giardia*

Samples will be analyzed for *Cryptosporidium* and *Giardia* using US EPA Method 1623, utilizing filtration, immunomagnetic separation, and immunofluorescence assay microscopy. The samples are filtered and the filtered materials are centrifuged, resulting in pellets containing cysts and oocysts which are magnetized to allow for separation from the extraneous materials. The cysts and oocysts are stained on slide wells with antibodies able to be detected using fluorescence and differential interference contrast microscopy. Oocysts and cysts are then identified qualitatively based on size, shape, color, and morphology. The total number of objects

on the slide provides a count of the pathogens present in the water samples. The EPA reference method for *Giardia* and *Cryptosporidium* analyses can be found in Appendix 7 of this QAPP.

#### 4.3.2.2 Analysis for *Salmonella*

In 2007 samples were analyzed for *Salmonella* spp. using US EPA Method 1682: *Salmonella* in Sewage Sludge (Biosolids) by Modified Semisolid Rappaport-Vassiliadis (MSRV) Medium.

#### 4.3.2.3 Analysis for *Shigella*

In 2007 samples were analyzed for *Shigella* spp. using standard method 9260E, (APHA, 2005)

#### 4.3.2.4 Analysis for *Pseudomonas aeruginosa*

In 2007 samples were analyzed for *Pseudomonas* using standard method 9213E, Membrane filter Technique for *Pseudomonas aeruginosa* (APHA, 2005)

### 4.3.3 Selection of commercial laboratories

Based on the results of a head-to-head comparison of two commercial laboratories that included evaluation of the performances (described in detail in the July 2007 QAPP: Water and Sampling Analysis document), up-to-date laboratory SOPs, capacity, turnaround time, data product, accessibility (weekends, holidays), distance and cost, Enviro-Test/Perry Laboratories was selected as the commercial lab to analyze samples for enterococci and *E. coli* using US EPA Methods 1600 and 1603, respectively. Scientific Methods, Inc. will conduct the analyses for coliphages (Method 1602) with serotyping of F+ RNA coliphages; *Cryptosporidium* and *Giardia* (Method 1623), and norovirus. In 2007, CFC samples were also analyzed for *Shigella* (Method 1682), *Salmonella* (SM 9260E) and *Pseudomonas aeruginosa* (SM 9213E). Additionally, SMI will make available the CFC and virus sampling kits required for this study, and will archive water samples for potential future analyses.

## 4.4 Quantitative polymerase chain reaction pilot study

### 4.4.1 Overview

A qPCR pilot study has been designed to address the following objectives: 1) to establish the precision and accuracy of qPCR for CAWS samples collected at areas of high and low enterococci concentration, 2) to characterize the relationship between qPCR and USEPA method 1600 for enterococci and 3) to evaluate the impact of freezing CAWS samples on pPCR results. Because measures of enterococci by qPCR are thought to correlate with viral pathogens in

surface waters, we will also measure other indicators and pathogens at the same times and places where samples are collected for qPCR measurement of enterococci .

qPCR enterococci testing does not address the needs of the Illinois EPA and, for that reason, will not be part of the basic set of tests for indicator microbes (namely *E. coli*, enterococci, and coliphages) performed on all water samples. However, it would increase the relevance of the epidemiology study if it were possible to compare results obtained in this study to those which use qPCR testing. A small scale study is in development that would allow us to meet the objectives listed above. A commercial laboratory (Mycometrics) that has experience in analyzing surface water sampling for enterococci by aPCR and has worked closely with the US EPA in developing draft methods for such analyses, will analyze our samples. qPCR testing will not become part of the basic package of indicator analyses performed as part of the ongoing epidemiologic study.

## **5. Quality Objectives and Criteria**

In order to monitor laboratory performance, study personnel will send to the lab performance evaluation samples such as method blanks, matrix spikes and sample splits. The laboratories are required to adhere to the quality control procedures provided in the US EPA Methods 1600, 1602, 1603, and 1623 documents. These procedures include initial and ongoing precision and recovery tests, media sterility checks, and record maintenance.

### **5.1 Indicator bacteria water samples**

#### **5.1.1 Method Blanks**

For each method of analysis, at least one field blank will be included with every 20 samples sent to the laboratory. Blanks consisting of sterile buffer solution will be prepared by the water sampling technicians at the end of the first round of sampling every day of sampling.

#### **5.1.2 Replicate Samples**

For each method of analysis, at least one sample for every 20 samples collected will be split in the field among three bottles, two of which will be sent to the lab to evaluate precision, the third will be prepared with the matrix spike material (see section 5.1.3).

### 5.1.3 Matrix Spikes

For each method of analysis, the third bottle of the split sample (see section 5.1.2) will be prepared with the matrix spike material by the water sampling technician. This will occur for at least 5% of the samples collected each day. See Appendix 11A-C for spike materials details.

Location group	E. coli (cfu/100mL)	Enterococci (550cfu/100 mL)	Coliphages (Somatic: 10,00pfu/mL; F+: 1,000 pfu/mL)	Giardia & Cryptosporidium (160 (oo)cysts)
GUW: Lake Michigan	550 x 1	1	1 mL	1/20L
GUW: other	550 x 1	6	1 mL	1/20L
CAWS-N	10,000 x 1	10	1 mL	1/20L
CAWS-S	550 x 1	4	1 mL	1/20L

Table 4: Spiking levels by location.

### 5.1.4 Method Performance

Laboratories are required to meet (or exceed) all method performance specifications of EPA Methods 1600, 1602 and 1603. Performance requirements of Methods 1600 and 1603 are described in detail in the method documents and are summarized in Table 5. Performance requirements of Methods 1602 is described in detail in the method document is summarized in Table 6.

QC Measures	Method 1603 (E.coli)		Both Methods		Method 1600 (Enterococci)	
	Procedure	Criteria (BioBall)	Note	Frequency	Procedure	Criteria (BioBall)
<b>IPR</b> (Init. Precision & Recovery)	4x100mL PBS +spikeATCC#11775 1x50mL MB	Mean %Recovery: <b>Detect-144%</b> Precision RSD 61%	Chart with OPR	Before sample collection start (once)	4x100mL PBS +spikeATCC#19433 1x50mL MB	Mean %Recovery: <b>85-106%</b> Precision RSD 14%
<b>OPR</b> (Ongoing Precision & Recovery)	1x100mL PBS +spikeATCC#11775 1x50mL MB	%Recovery: <b>Detect-144%</b>	Chart with IPR through all time	1/20 sample (5%)	1x100mL PBS +spikeATCC#19433 1x50mL MB	%Recovery: <b>78-113%</b>
<b>MS</b> (Matrix Spike)	1xXXmL +spike ATCC#11775 1xXXmL unspiked 1x50mL MB	%Recovery: <b>17-117%</b>	Control chart for matrices (Rec. based on disinfect. ww)	1/20 sample (5%)	1xXXmL +spike ATCC#19433 1xXXmL un-spiked 1x50mL MB	%Recovery: <b>63-110%</b>
<b>MB</b> (Method Blank)	1x50mL PBS or dilution W>>mTEC	Absence of growth		Every day when sample analyzed	1x50mL mEI agar	Absence of growth
Positive Control	1xXXmL diluted E. coli (ATCC#11775)	Growth	Count	Every day when sample analyzed (+ new batch of media)	1xXXmL diluted Enterococci (ATCC#19433)	Growth
Negative Control	1xXXmL diluted E. faecalis (ATCC#19433)	Absence of growth		Every day when sample analyzed (+ new batch of media)	1xXXmL dil E. coli (ATCC#11775)	Absence of growth
Filter sterility check	1 filter placed on TSA plate>incubate	Absence of growth		Every day when sample analyses	1 filter placed on TSA plate>incubate	Absence of growth
Filtration Blank	1x50mL PBS filtered >TSA plate>incubate	Absence of growth		Every day before beginning sample analyses	1x50mL PBS filtered >TSA plate>incubate	Absence of growth
Media Sterility Check	1 from each batch of medium	Absence of growth		Every day when sample analyses	1 from each batch of medium	Absence of growth
Media Verification	All 4 media tested with positive and negative controls	Absence of growth		When new batch or reagents used	All 3 media tested with positive and negative controls	Absence of growth
Colony Verification	1 typical colony/ 10 positive samples 1 atypical colony/10 positive samples	E. coli	Verify	1/10 positive samples (or 10/month) for both typical and atypical colonies	1 typical colony/ 10 positive samples 1 atypical colony/10 positive samples	E. faecalis

**Table 5. Summary table for QA/QC Requirements for methods 1600 and 1603 (Enterococci & E.coli)**

QC Measures	Procedure (both separately)	Criteria		Note	Both Methods
		Male-specific	Somatic		Frequency
IPR (Init. Precision & Recovery)	4x100mL Reag W +spike 80PFU (bulk spike!) 1x100mL MB	Mean % Recovery: 9-130% Precision RSD 46%	Mean % Recovery: 86-177% Precision RSD 23%	Chart with OPR	Before sample collection start (once)
OPR (Ongoing Precision & Recovery)	1x100mL Reag W +spike 80PFU 1x50mL MB	%Recovery: 4-135%	%Recovery: 79-183%	Control chart after 5 value; Ave R% & s (Stdev); % R interval plot R-2s; R+2s; update on a reg. basis	1 with each analyzed batch (batch <= 20 samples)
MS (Matrix Spike)/MSD (duplicate)	2x100mL +spike 80PFU 1x100mL unspiked	%Recovery: Detect-120% Precision (RPD) 57%	%Recovery: 48-291% Precision (RPD) 28%	Control chart for matrices and update on a reg. basis	First received source and 1/20 sample (5%)
MB (Method Blank)	1x100mL Reagent W > same anal as samples	No coliphage PFU	No coliphage PFU		1 with each batch of sample
Positive Control >OPR serves it					See OPR

**Table 6. Summary table for QA/QC Requirements for method 1602: Male-specific (F+) and Somatic Coliphage in water**



## 5.2 Filtration samples for pathogens

### 5.2.1 Method blanks

Sterile buffer solutions prepared in the UIC SPH laboratories will be used to process virus and CFC blanks. To ensure that at least one field blank will be included with every 20 samples sent to the laboratory, blanks will be prepared by the water sampling technicians immediately upon collection of the final sample in a group to be sent to the lab. Thus, each shipment of samples will include one field blank.

### 5.2.2 Matrix spikes

Study personnel will spike one sample aliquot for *Giardia* and *Cryptosporidium* for approximately every 10 samples sent to the laboratory for analysis. In 2007, BioBalls spikes were used. In 2008 spike materials from the Wisconsin State Hygiene Laboratory will be used. For coliphage analyses spike material provided by the Scientific Methods, Inc. was found in 2007 to produce more consistent results than those obtained as BioBalls from BTF, Inc. In 2008 only Scientific Methods, Inc. material will be used. The target concentration of the male-specific coliphage spike material is 10,000 pfu/mL and for somatic coliphages, 1,000 pfu/mL. A volume of 1mL from both male-specific and somatic coliphages spike material is pipetted into the specified samples. Once each week, 60 liters of water will be collected for matrix spiking, completed in the UIC laboratory. The matrix to be spiked will rotate weekly from among the following four groups: CAWS-North, CAWS-South, Lake Michigan, and other general use waters. Samples from CAWS-North, CAWS-South, Lake Michigan, and other general use waters are spiked at a frequency of approximately one spike per 10 samples for each of 1600, 1602, and 1603 methods.

### **Spiking 1600 / 1603 samples (Indicator bacteria)**

1600 = enterococci

1603 = *E. coli*

- Identify spike samples from FDS
- Match sample method with correct spike material from above
- Open sample
- Adjust volume to 170ml line if necessary
- Open correct BTF bioball vial
- Insert ball into sample
- Close lid tightly
- Agitate sample
- Circle sample in the FDS, write # of vials added and your initials

### **Spiking 1602 samples (Indicator viruses, coliphages)**

- Identify spike sample from FDS
- Take “Coliphages” label container from refrigerator and put it in the chemical hood
- Open container, identify 2 test tubes inside (MS2 male specific and somatic coliphages)
- Open sample
- Adjust volume to 450ml if possible (compare to the empty bottle in hood with volume lines)
- Attach a 1mL pipette to pipetter
- Open the MS2 male specific test tube, mix material with the pipette and pipette exactly 1mL material into the sample (touch the pipette tip to the upper neck of sample bottle to remove the remaining material in the pipette)
- Cap the spike material
- Repeat the procedure with the somatic coliphage using clean pipette
- Close sample bottle lid tightly
- Agitate sample
- Circle sample in the FDS, write down sample volume, number of coliphages from the test tubes and your initials
- Put spike material back to refrigerator

### **Spiking CFC samples (Parasites: *Giardia* and *Cryptosporidium*)**

- Take “Parasites” label container from refrigerator and remove one vial from it
- Agitate vial with circular movement for ~30seconds and remove parafilm
- Identify spike sample (20L container) from FDS
- Empty contents of vial into sample and rinse vial at least 3 times with sterile buffer (pour buffer to tube, cap and shake, repeat)
- Close sample and agitate by rolling it from one side to the other
- Circle sample in the FDS, write down spike tube number and your initials

### 5.2.3 Method Performance

Laboratories are required to meet (or exceed) all method performance specifications of EPA Methods 1623. These are described in detail in the method document and summarized in Table 7.

QC Measures	Procedure	Criteria		Note	Both Parasites
		Cryptosporidium	Giardia		Frequency
IPR (Init. Precision & Recovery)	4x20L ReagW +spike ~100-500 Cryptoocysts and ~100-500 Gia cysts 1x20L MB	Mean % Recovery: 24-100% Precision: RSD 55%	Mean % Recovery: 24-100% Precision: RSD 49%	Examine & doc slides for each sample; 1 <sup>st</sup> 3 Crypto & 1 <sup>st</sup> 3 Gia ID, characterize (size, shape, DAPI, DIC cat.) 50%Undamaged, morf. intact oocysts &cysts (200x;400x magnification) Examination form fill	Before sample collection start (once if meet criteria) 4 spikes + 1 MB
OPR (Ongoing Precision & Recovery)	1x20L ReagW +spike ~100-500 Crypto oocysts and ~100-500 Gia cysts 1x20L MB	%Recovery: 11-100%	%Recovery: 14-100%	Examine & doc slide; 1 <sup>st</sup> 3 Crypto & 1 <sup>st</sup> 3 Gia ID, characterize (size, shape, FITC, DAPI, DIC cat.) 50%Undamaged, morf. intact oocysts &cysts (200x;400x magnification) Report form must be filled	1 each week or 1 for every 20 sample if more than 20 samples/week; 1 spike + 1MB
MS (Matrix Spike)/MSD (duplicate)	1 or 2x20L (split) sample +spike ~100-500 Crypto oocysts and ~100-500 Gia cysts 1x20L Un-spike sample matrix	%Recovery: 13-111% Precision (RPD) 61%	%Recovery: 15-118% Precision (RPD) 30%	Control chart for matrices when 5 sample available and update on a reg. basis P-2s to P+2s (mean recov: P; std: s)	First received source and 1/20 sample (5%) for source 1-2 spikes + 1 un-spike
MB (Method Blank; negative control)	1x20L Reagent W > same anal as samples	No interfering organisms with Crypto oocysts	No interfering organisms with Giardia cysts	If criteria meets, acceptable MB	1 with IPR; 1 with OPR weekly with samples
Positive Control >OPR serves it					See OPR

**Table 7. Summary table for QA/QC Requirements for method 1623: Cryptosporidium and Giardia**

### 5.3 Basic water quality parameters

Conductivity, turbidity, dissolved oxygen, pH and temperature will be measured by field sampling personnel at the time of microbial sampling using portable instruments. Parameters will be measured at least once per day at each sampling location.

#### 5.3.1 Turbidity

Turbidity will be measured with an HP Scientific MicroTPW portable turbidimeter. This instrument uses a white light (tungsten) source and conforms to USEPA Method 180.1. Resolution is 1% of full-scale (10, 100 or 1100 NTU) with an accuracy of  $\pm 2\%$ .

#### 5.3.2 Conductivity

Conductivity will be measured using an Oakton Acorn CON6 Conductivity/TDS/Temperature portable field meter, which measures conductivity from  $0.0\mu\text{S}/\text{cm}$  to  $200\text{mS}/\text{cm}$  with resolutions of  $0.1\mu\text{S}$ ,  $1\mu\text{S}$  and  $0.01\text{mS}$  and relative accuracy of  $\pm 1\%$  full scale.

#### 5.3.3 DO, pH, temperature

Dissolved oxygen, pH and temperature will be measured with an Accumet AP84 portable pH/dissolved oxygen meter. The DO range is  $0.00$  to  $20.00\text{mg}/\text{L}$  with a resolution of 1.5% of saturation and an accuracy of 1.5% of full scale. The pH range is  $-2.00$  to  $16.00\text{pH}$  with a resolution of  $\pm 0.01\text{pH}$  and an accuracy of  $\pm 0.01\text{pH}$ . The temperature probe will be calibrated against a NIST standard. These instruments will be used and calibrated per the manufacturer's instructions.

### 5.4 QA/QC Procedures

Implementation of the QA/QC procedures for surface water evaluation will be established through the following steps:

5.4.1 Ensure that each field team member is familiar with the provisions of the QAPP. The Water Project Manager will ensure that each field team member is familiar with the field sampling SOPs and QAPP prior to implementation of field activities.

5.4.2 The Data Quality Manager, with the assistance of the Water Project Manager, will regularly perform a QA review of field activities and field data sheets to ensure that all procedures are followed.

5.4.3 The Data Quality Manager will verify that all contracted laboratories have a written description of their QA activities and a QA plan describing the QA management

of day-to-day routine operations. UIC personnel will conduct telephone interviews and visit the laboratories before any project samples can be evaluated.

5.4.4 The laboratories contracted to evaluate samples are required to adhere to defined quality assurance procedures to ensure that generated analytical data are scientifically valid and are of known and acceptable precision and specificity.

5.4.5 Quality control charts will be maintained for every parameter measured for the study including blanks, calibration factors, and measures of precision for each parameter. The Data Quality Manager will initially perform weekly reviews and specify corrective action as needed. Once acceptable performance is established, this review will be conducted monthly or more often if needed.

## **6. Special Training/Certification**

### 6.1 Surface water sampler qualification

A high school diploma and one year of college level laboratory course work is required. Samplers should be physically fit and not afraid of water (know how to swim). Medications causing dizziness are inadvisable.

### 6.2 Description of Training

Surface water samplers must participate in a 2-hr in-class training and a 2-hr field training conducted by the Assistant Project Director, Water Data.

#### 6.2.1 Laboratory Training

During the in-class training section, water samplers are instructed about the surface water sample collection technique and handling of sample containers for microbiological analysis following the protocol. Health effects of possible pathogens and techniques for safely handling contaminated water are emphasized. Water samplers learn the use and calibration of portable meters to measure basic water quality parameters (principle of operations is included). The parameters to be measured are: water and air temperature; dissolved oxygen, pH; turbidity and conductivity.

#### 6.2.2 Field Training

Field training will be held at one of the sampling sites. Samplers will learn to sample for microbes, prepare sample bottles for transportation, measure water quality parameters and record all data on Field Data Sheets. Safety on waterways will be emphasized.

### 6.2.3 Performance Evaluation

The performance of trainees will be evaluated visually after repeating sampling and sample handling five times. Water quality parameters are measured and documented five times by each sampler and calibration of meters before and after the measurements. Relative standard deviation should be within 5%. Sampler's performance will be evaluated. If he or she used proper sampling technique and demonstrated satisfactory variability of basic water quality parameters, he or she will be approved for field sampling. The performance of trainees will be documented in a Training Log-book.

### 6.2.4 Frequency of Training

Initial training will occur at the time of hire. Refresher training will take place if quality monitoring identifies potential problems (positive field blanks, high variability in split samples).

## **7. Documents and Records**

7.1 Water quality sampling Field Data Sheets (FDS) must be completed on-site at the time sampling occurs. Appendix 12 presents a sample FDS. The FDS has been developed to facilitate both completion in the field and the subsequent merging of laboratory results with data regarding the time, place, and conditions of water sampling. Identification of site sample number, date of collection, sample volume analysis required and sample type (blank, split, spike) will be pre-printed on the FDS. The time of sample collection, sample volume, sampler's name, water quality parameters, and environmental conditions will be recorded by the field technician at the time of sample collection. Special notes about unusual observations require documentation. Completed FDS must be submitted to the Assistant Project Director promptly (within one day). FDS will be maintained for 5 years after completion of the project.

7.2 A separate Field Log Book (Appendix 13) is maintained for each site and filled in by the Water Project Manager using information in the FDS. The Field Log Book is kept in a safe place and not allowed to be taken to the field where it could be damaged/destroyed (rain, wind, dropped in river). It is maintained for 5 years after completion of study.

7.3 The custody of water samples is documented when the sampler and the sample courier sign the Chain of Custody (COC) record at the time of transfer. A copy of the COC will be faxed to the Water Project Manager and the Project Coordinator within 48 hours of sample receipt.

7.4 The contracted laboratories send results of lab analyses electronically that are then maintained by the Water Project Manager. Results will be sent as both an Excel file and as a PDF document bearing the laboratory letterhead and signature of the commercial lab manager. Upon receiving results, hard copies are printed out, computer back-up disks made, and copies distributed to the Project Coordinator. Laboratory results will be maintained for at least 5 years after completion of the project.

## **B. DATA GENERATION AND ACQUISITION**

### **1. Sampling Process Design (Experimental Design)**

#### 1.1 CAWS sample locations

The location(s) for enrolling participants into this epidemiologic research study on a given date will determine the locations of water sampling at the CAWS and will reflect the frequency of actual CAWS usage, by recreational activity and location.

For each enrollment location we will sample water at the approximate location of water entry every 2 hours. Additionally, water will be sampled upstream and downstream of the nearest upstream WRP twice a day (before the beginning of event and at the end). For research participant enrollment locations on the North Branch of the Chicago River, water samples will also be taken from the North Branch upstream of the North Branch Dam. Exact locations of water sampling are presented in Appendix 5 and Appendix 6 of the Overview document. Table 8 presents a summary of water sampling locations by CAWS enrollment sites.



Enrollment site	Water sampling locations			
	At access point	Upstream of WRP	Downstream of WRP	Upstream of NB Dam
Skokie Rowing Ctr.	√	Bridge Street	Lincoln Avenue	
River Park	√	Bridge Street	Lincoln Avenue	√
Clark Park	√	Bridge Street	Lincoln Avenue	√
North Ave sites	√	Bridge Street	Lincoln Avenue	√
Main stem	√			
Bubbly Creek, Ping Tom	√	Bridge Street	Lincoln Avenue	√
Calumet Boat Launch	√	Beaubien Woods	Riverdale Marina	
Worth Boat Launch	√	Beaubien Woods	Riverdale Marina	
Alsip Boat Launch	√	Beaubien Woods	Riverdale Marina	

**Table 8: Locations of water sampling, by participant enrollment site, CAWS sites**

### 1.2 General Use sampling locations

For enrollment sites of the GUW group (Lake Michigan, the Skokie Lagoons, Crystal Lake, and the Des Plaines, Fox, and Kankakee Rivers), water sampling locations will be determined by the site and type of study participants' recreational activities. Samples will be taken at the launch site for boaters and paddlers except for beach-launch paddlers. Water sampling for fishing subjects will happen at the point of recruitment (where they are fishing).

The interval between sample collection at a given site on a given date will be every two hours, the same as the interval between CAWS sampling. Samples will be collected using a telescopic pole at launch sites (for boaters and paddlers) and near the study participants (in the setting of fishers from shore).

## 2. Sampling Methods

### 2.1 Collection of Surface Water Samples for Indicator Organisms

2.1.1 A grab sample (discrete aliquot representative of a specific location/time) will be collected using a telescopic pole fitted with a bottle holder, collecting the surface layer only (up to 10 cm of depth) directly into sterile high-density polyethylene sampling bottles.

Sampling Site	Size of sample bottle		
	E. coli	Enterococci	Coliphage
CAWS	200 mL	200 mL	500 mL
General Use	200 mL	200 mL	500 mL

**Table 9: Size of direct sampling bottles**

The volumes (Table 9) were chosen based on the suggestion from literature that [6] “the minimum volume collected should be three to four times the amount required for the analysis”.

2.1.3 Preservation of surface water samples will not be required for the indicator organism analyses as none of the sources contain residual chlorine. (None of the Wastewater Treatments Plants chlorinate effluents and Lake Michigan has no detectable level of chlorine residual.) Sampling bottles will be used without preservative (e.g. sodium thiosulfate or other).

2.1.4 Samples will be collected from the channel/river cross-section (left-stream or right-stream, facing upstream) location nearest the access point. In addition, sampling approximately ¼ mile upstream and ¼ mile downstream of Skokie Rowing Center will be collected in conjunction with access point sampling at that location. Sampling sites will be mapped for each event and provided to the sampler with the Field Data Sheets.

2.1.5 Method blanks, field splits, and matrix spikes will be prepared at every access point where samples are being collected. Details are provided in section B.5. Five percent of samples sent to the lab for analysis will be field blanks. The number of field blanks collected will be determined by the total number of samples collected. On days when more than one field blank will be collected, blanks will be collected at more than one sampling site.

2.1.6 At least 5 percent of samples or 1 per method per day, whichever is greater, sent to the lab for analysis will be matrix spike samples. The number of matrix spike samples will be determined by the total number of samples collected. All samples will be spiked at a single location each day; locations will vary by day.

## 2.2 Water sampling by field filtration

Scientific Methods, Inc. (SMI) of Granger, IN has made available to the research team a continuous flow centrifugation (CFC) system for use in the field or laboratory (Appendix 14). This system has Tier 2 EPA approval for use in *Cryptosporidium* analyses (Appendix 10). Additionally, SMI has developed a “Virus Sampling Kit” consisting of a 2L per minute pump and a ViroCap 5-inch filter (Appendix 15). SMI will train UIC personnel to use the CFC and virus sampling systems according to each system’s Standard Operating Procedures (SOP) (see Appendix 16 for CFC SOP).

CFC samples are collected with non-filtering diaphragm water sampling pumps at each location. Samples are collected into 20 liter sterile cubitainers using new tubing for each sample. Samples are either processed by centrifugation upon delivery to the laboratory or refrigerated until processed. Following processing, CFC bowls are refrigerated and shipped cold.

All analyses will be performed by SMI as follows: Aliquots from the CFC bowl will be used for analyses of *Giardia* and *Cryptosporidium* oocysts.

Direct method, CFC, and simple filtration samples will be analyzed for *E. coli* and enterococci by EPA reference methods 1603 and 1600, respectively. CFC and simple filtration samples will be analyzed for microbes using methods listed in Table 2.

2.2.1 SMI will perform all QA and QC procedures required for each method and follow internal QA practices required for certification by the Indiana Department of Public Health for analyses of drinking water sources.

2.2.2 Laboratory results will be transmitted electronically to the director of the Water Sampling and Analysis project by e-mail.

### 2.2.3 CFC and virus sampling in the epidemiologic study

2.2.3.1 Water samples for the analysis of pathogens will be collected every day that direct method water sampling will take place (in other words, on days that CAWS group and Lake group participants are enrolled). For WRP-oriented sampling, water will be collected first upstream of the WRP, and approximately 30 minutes later from the downstream location. One access point sample, one sample upstream of the WRP, and one sample downstream of the WRP will be collected for pathogen analysis, in parallel with the direct method sampling. Throughout the 2007 season, samples were filtered

directly from the waterway by the CFC. Because of a nation-wide limited supply of CFC systems, for the 2008 season samples are collected in 20L cubitainers and then transported to the UIC lab to be filtered through the CFC. This method of collection was chosen in consultation with the scientific review committee. The CFC sampling will take place streamside/lakeside, as close as possible to water as permitted by safety considerations. Study staff will monitor the filter systems to ensure that the pumps are functioning properly and that the sampling tubing extends at least 10 feet from the water's edge.

#### 2.2.4 Quality monitoring

##### 2.2.4.1 Blank samples

Sterile, buffered water samples from the UIC SPH laboratories will be used to prepare virus and CFC blanks for analysis.

##### 2.2.4.2 Virus replicates

Every other week, 1 set of replicate virus samples will be created by filling a 200L drum with water, at either a CAWS or general use location. Two 100L samples for viral analyses will be collected, one right after the other.

##### 2.2.4.3 CFC replicates

Every other week, two aliquots from the same CFC bowl will be sent for bacterial and protozoal analyses.

2.2.4.4 Aliquoting of CFC samples will be as described in the SOP. One aliquot will be kept at SMI -80°C.

2.2.4.5 Sample handling and transport will be as outlined in Section B.3, below.

#### 2.3 Water Quality Parameters for Field Data Sheets

At each sampling location basic water quality parameters will be measured and recorded on the FDS (Appendix 12). Turbidity will be measured with an HP Scientific MicroTPW portable turbidimeter. DO (dissolved oxygen), pH and temperature will be measured with an Accumet AP84 portable pH/dissolved oxygen meter. Conductivity will be measured using an Oakton Acorn CON6 conductivity meter. All meters will be operated and maintained according to the manufacturer's instructions. Meters will be calibrated in the UIC lab with certified standard materials before readings are taken for pH and DO (Accumet AP84 pH/DO/mV meter) and turbidity (Micro TPW) and conductivity (Oakton

Acorn CON6) at the site. During a full day of sampling recalibration is necessary. Calibrations are documented in the log books for equipment maintenance and calibration.

#### 2.4 Meteorology Data for Field Data Sheet

Cloud cover, current precipitation and precipitation in the preceding 72 hours will be recorded on the FDS (Appendix 12).

#### 2.5 Equipment/Materials

The checklist of equipment and materials necessary for water sampling and safety is listed below:

- 20 Liter sterile LDPE cubitainer
- New 0.5" ID sample transfer tubing
- Shurflo non-filtering viton diaphragm sampling pumps
- Safety gloves, powder-free
- Sterile sample bottles (plastic, high-density polyethylene (HDPE), 250-mL)
- Sterile sample bottles (plastic, high-density polyethylene (HDPE), 1-L)
- 500-mL sterile water (pyrogen-free) for field blank at each site and each day
- Ziploc bags (7 in x 8 in for holding sample bottles)
- Paper towel
- Coolers (at least two for two different laboratories)
- Ice Packs
- Duct Tape
- Waterproof pen (several)
- Sample-bottle labels (waterproof, preprinted with data available)
- Accumet AP84 portable pH/dissolved oxygen meter
- HP Scientific MicroTPW portable turbidimeter
- Oakton Acorn CON6 conductivity meter
- Field Logbook
- Chain-of-Custody Records (from laboratories, Appendices 7-9)
- (Water Quality Sampling) Field Data Sheets
- Clipboard with plastic cover (protect from water splash)
- Site location information, including maps and photographs
- Tape measure

- Insect repellent/sunscreen (optional)
- Small first aid kit (optional)
- Whistle (to summon help in emergency, optional)
- Refreshments/drinking water (optional)
- Rope
- Camera/film (optional)
- Bottle of tap water (for rinsing exposed skin)
- Trash bag (to collect used safety gloves and other trash)
- CHEERS study contact list
- Cellular telephone

## 2.6 Collection of Surface Water Samples using Telescopic Pole

2.6.1 Select a bottle with a pre-printed label. Labels are coded based on the type and location of sample being collected. Make sure that you are choosing the correct type and location for sampling.

2.6.2 Verify that the bottle looks clean and remains sealed before starting to sample. If sterility is questionable, deface the label and do not use the bottle.

2.6.3 Write the time and sampler's initials on the label with a waterproof pen

2.6.4 Put safety gloves on and remove the bottle cap carefully, ensuring that you do not touch the inside of the cap or bottle.

2.6.5 Position the bottle in the holder at the end of the telescopic pole. Ensure that the bottle is secure in holder and holder is tightly affixed to pole.

2.6.6 While standing at the access point, extend the pole making sure that all sections are fully extended and tight fitting.

2.6.7 Immerse bottle (holding it about 45 degree) facing upstream so that water surface and the upper 10 centimeter (~4 inches) layer are included in the sample (avoid surface debris if possible).

2.6.8 Raise bottle out of water, retract pole.

2.6.9 Remove bottle from holder.

2.6.10 Pour off excess water until the water level is at the fill line or leave about 1-in air space (for proper mixing purpose before analysis).

2.6.11 Recap the bottle (tight enough) and dry off the bottle with paper towel.

2.6.12 Place sample in zip-lock bag and put it in insulated cooler.

2.6.13 Fill in the Field Data Sheet with times and initials (same as on bottle).

2.6.14 Fill in the Chain-of-Custody (COC) record (Appendix 17,18).

2.6.15 Turn over the coolers to the assigned custodian for transportation to the analyzing laboratory. He/she must sign the Chain-of-Custody record.

2.6.16 Wait until the cooler is sealed with tamper proof tape.

2.6.17 Return Field Data Sheets to Water Project Manager as soon as possible.

## 2.7 Collection of Field Split samples

2.7.1 Field splits are used to estimate sampling and laboratory analysis precision. Field split samples are to be collected the same way as the regular samples except that a higher volume sterile sample container (1-liter) will be used for sampling. The 1-liter container is used to collect water and split between three regular sterile sample containers. Regular sample bottles must be labeled and ready for filling by the time of sampling. All bottles must be kept closed, to be opened for sample filling only and using aseptic technique. Before splitting, the sample must be shaken up. One staff member will open the sample bottle and the other one will fill them (from the 1-liter container).

2.7.2 Collect a minimum of two sets of field replicate samples every day of field sampling. A minimum of 5% of all samples will include a split. Preferably, this should take place at the access point closest downstream to a WRP.

2.7.3 When sampling will take place at a given access point more than once, the splits will be prepared at the end of the sampling day.

2.7.5 Follow the steps of "Collection of surface water samples" (from 2.5.1.1 to 2.5.1.11) for the collection of field split samples. They are to be processed the same way as regular samples sent to the laboratory.

## 2.8 Preparation of Field Blanks

2.8.1 Sterile buffer will be available for the preparation of field blanks.

2.8.2 At least one field blank for every 20 samples of each method will be prepared on each day of sampling, the total number to be determined by the number of samples collected. If more than one blank is needed, then blanks will be prepared at more than one location.

2.8.3 Field blanks will be prepared at the end of the sampling day.

2.8.4 Procedure for preparing field blanks:

2.8.4.1 Locate the sterile bottle of water and the “field blank” coded sample bottles.

2.8.4.2 Initial and note the time on the sample bottle label.

2.8.4.3 Uncap the sample bottles and fill them up with the sterile water until fill-line.

2.8.4.4 Continue the procedure from the 13th step of the “Collection of surface water samples” (these are handled like regular samples)

2.9 Procedures for 20 liter cubitainer sample collection

2.9.1 Wear new gloves

2.9.2 Connect new sample transfer tubing to sample pump

2.9.3 Position inlet tubing ~6” below surface of source water but not in bottom or debris

2.9.4 Open pre-labeled 20 Liter cubitainer

2.9.5 Insert tubing into cubitainer

2.9.6 Fill cubitainer near full and cap

2.9.7 Record sample time, volume, and sampler initials on label and data sheet

2.9.1 Transfer to UIC laboratory

2.10 Virus sample collection

2.10.1 Wear new gloves

2.10.2 Remove inlet and outlet caps from pre-labeled filter

2.10.3 Connect new sample transfer tubing to filter inlet

2.10.4 Position inlet tubing ~6” below surface of source water but not in bottom or debris

2.10.5 Connect tubing from filter outlet to sample pump

2.10.6 Turn pump on and filter 100 liters from water source

2.10.7 Replace filter inlet and outlet covers after sample collection



2.10.8 Record sample time, volume, and sampler initials on label and data sheet

2.10.9 Store in cooler and transfer to UIC laboratory

### 2.11 Safety Precautions for Samplers

2.11.1 Rivers are under the direct influence of treated wastewater discharge. Fecal contamination or pathogens may be present.

2.11.2 Use disposable safety gloves when collecting samples (have a bag with you for collecting contaminated ones)

2.11.3 Wash your hands thoroughly after sampling; use hand sanitizer when hand washing facilities are unavailable.

2.11.4 Do not touch your eyes, ears, nose, or mouth until you've washed your hands

2.11.5 Operating in and around bodies of water carries the inherent risk of drowning. Collecting samples in cold weather, especially around cold water bodies, carries the risk of hypothermia and collecting samples in extremely hot and humid weather carries the risk of dehydration and heat stroke. Sampling team members should wear adequate clothing for protection in cold weather and should carry an adequate supply of water or other liquids for protection against dehydration in hot weather.

## **3. Sample Handling and Custody**

### 3.1 Sample Handling

All requirements for methods 1600 and 1603 for sample containers, preservation techniques, sample volumes and holding times will be met. Specifically, all bacteria samples will be held at 1-4°C during transit to the laboratory, and the time between sample collection and the initiation of analysis will not exceed 6 hours. The laboratory will provide certified-clean sample containers. Separate sample containers for QC samples will also be provided by the analytical laboratory.

### 3.2 Sample Identification

Samples are to be identified on the sample container with a separate identification label. All labeling will be done in indelible/waterproof ink. Any errors will be crossed out with a single line, dated, and initialed.

### 3.3 Sample Custody

After collection and identification, samples will be maintained under chain-of-custody procedures specified by the analytical laboratory. Proper sample custody procedures will be used to ensure that samples have been obtained from the locations stated and that they have reached the laboratory without alteration. A sample is considered to be in a person's custody if the sample is:

- in a person's actual possession;
- in view after being in a person's possession;
- locked so that no one can tamper with it after having been in physical custody; or
- in a secured area, restricted to authorized personnel

All samples will be accompanied by a Chain-of-Custody Record. When transferring samples, the individuals relinquishing and receiving the sample will sign and date the record. Once the samples have been received by the laboratory, a designated laboratory person will check all incoming samples for integrity and note any observations on the original Chain-of-Custody Record. Each sample will be logged into the laboratory system by assigning it a unique laboratory sample number. This number and the field sample identification number will be recorded on the laboratory report. The laboratory will maintain a file of all the documents (e.g., Chain-of-Custody forms) pertinent to sample custody and sample analysis protocol. For Chain-of-Custody forms, the laboratory maintains a file copy and the completed original will be returned to the Water Project Manager as part of the final analytical report. This record will be used to document sample custody transfer from the sampler to other personnel or the laboratory.

#### 3.4 Sample Packaging, Shipment, and Tracking

All samples will be delivered directly to the analytical laboratories by study staff, lab staff, or commercial courier service.

#### 3.5 Labeling/Identifying Water Samples

3.5.1 Samples will be identified on the sample container with pre-printed waterproof identification labels. Sampling times and initials will be added with waterproof ink. After securely affixing them, labels will be covered with transparent tape.

3.5.2 Sample identification code on the labels will code for location, sample type, required analysis, sample number, required procedure, date and time.

3.5.3 Sampling location codes are listed in Appendix 19.

### 3.5.4 Sample Type Code

- Blank (sterile water): BK
- Sample (regular sample): SP
- Field replicate (duplicate): FR
- Matrix spike sample: MS
- Matrix spike Sterile Water (blank spike): BS

### 3.5.6 Sample number code

This number will be given to each sample starting from 1111 based on the Field Log Book's serial number

### 3.5.7 Required procedure with the sample:

- No filtration performed in field: N
- Simple filtration performed in field: F
- Centrifugation performed: C

### 3.5.8 Date and time of sample collection

- Date will be preprinted on label: month-day-year
- Write time using military time (e.g. 3:08 PM would be 1508)

### 3.5.9 Example of coding:

Sampling at Alsip, for indicator bacteria, 15th sample in the Field Log Book, directly sampled (no procedure), and collected on June 12th, 2:45PM;

Code: AL-SP-IB-15N-06-12-07-1445

### 3.5.10 Necessary information and appearance of label

#### 3.5.10.1 Sample Identification Code

3.5.10.2 Name or initials of samplers (if initials shown on the label, a separate sheet should be maintained showing the sampler's full name and initials (to be able to identify him/her)

#### 3.5.10.3 Date and time of sampling

#### 3.5.10.4 Requested Analyses (fully printed, no abbreviation)

#### 3.5.10.5 Analysis method numbers (e.g. 1600, 1602, 1603)

## 4. Analytical Methods

Water samples will be transported to a commercial EPA-certified analytical laboratory for measurement of indicator organisms. Based on the results of the first preliminary water sampling study (detailed in the 2007 QAPP: Water Sampling and Analysis document), Enviro-Test/Perry Laboratories was chosen as the commercial lab to analyze samples for E. coli and enterococci, using US EPA Methods 1603 and 1600, respectively. SMI will analyze samples for coliphages using US EPA Method 1602 as they are the only lab in the Chicago area able to perform the analysis. Laboratory certification and initial sample receipt protocols are found in Appendices 18-19.

The analytic laboratories will dilute samples using specific sample volumes using membrane filtration method for indicator organisms. We developed a series of 5 dilution volumes to be performed for all samples, based on sampling site (CAWS vs. lake/lagoon) for the following reasons:

- 1) For E. coli, the recommendations of “Microbiology Methods” text [3] are shown below in Table 10. Although this provides information about fecal coliforms, approximately 80-90% of the coliforms in the CAWS are E. coli. The “Range Covered” is consistent with Dry Weather Risk Assessment values for the dry season, with higher densities anticipated in the wet season.
- 2) For Enterococci analyses, we have chosen a lower dilution range based on the expectations that densities will be at least ten-fold lower than the E. coli density, as noted in the Dry Weather Risk Assessment.

<b>Sample Source</b>	<b>100</b>	<b>30</b>	<b>10</b>	<b>3</b>	<b>1</b>	<b>0.3</b>	<b>0.1</b>	<b>0.03</b>	<b>0.01</b>
Lakes, Reservoirs	x	x	x						
Bathing Beaches			x	x	x	x	x		
River Water					x	x	x	x	x
CFU/100-mL Range covered*	20-60	67-200	200-600	667-2,000	2,000-6,000	6,670-20,000	20,000 - 60,000	66,670-200,000	200,000-600,000

\* “CFU range covered” is calculated using membranes with 20-60 colonies (acceptable range)

$$\text{CFU/100-mL} = \# \text{ of colonies counted} \times 100 / \text{Volume of sample filtered, in mL}$$

**Table 10. Suggested range of sample volumes (mL) for fecal coliform tests using the membrane Filter Method**

Based on the knowledge of the pollution level of indicator organisms in CAWS, we have decided to request the analyses of 5 dilution levels from each river samples.

The dilutions to be performed on samples in this study, based on location of sampling are presented in Table 11 below. If filter clogging or interference is found to occur with the 100mL dilution volumes, that dilution volume will require reduction.

Location	Condition	Filtration/Dilution	
		E. coli (EPA 1603)	Enterococci (EPA 1600)
Lake Michigan (off shore and harbors)	Dry and wet weather	100; 30; 10; 3; 1 mL	100; 30; 10; 3; 1 mL
Skokie Lagoons	Dry weather	100; 30; 10; 3; 1 mL	100; 30; 10; 3; 1 mL
	Wet weather	30; 10; 3; 1; 0.3 mL	30; 10; 3; 1; 0.3 mL
North Shore Channel – Bridge St	Dry weather	30; 10; 3; 1; 0.3 mL	100; 30; 10; 3; 1 mL
	Wet weather	10; 3; 1; 0.3; 0.1 mL	30; 10; 3; 1; 0.3 mL
CAWS – North Side	Dry weather	10; 3; 1; 0.3; 0.1 mL	30; 10; 3; 1; 0.3 mL
	Wet weather	3; 1; 0.3; 0.1; 0.03 mL	10; 3; 1; 0.3; 0.1 mL
CAWS – South Side	Dry weather	100; 30; 10; 3; 1 mL	100; 30; 10; 3; 1 mL
	Wet weather	30; 10; 3; 1; 0.3 mL	30; 10; 3; 1; 0.3 mL

**Table 11: Dilution volumes, by sampling location, weather condition, and indicator**

## **5. Quality Control**

### **5.1 Interference and Potential Problems for Sampling**

5.1.1 Two main sources of possible interference and problems during surface water sampling can involve cross-contamination and improper sampling.

5.1.2 Improper sampling arises from unclean and non-sterile sample containers, improper sampling technique or improper shipment procedures. Improper sampling can be reduced by using standardized procedures for collecting, handling and shipping samples and following the procedures of the SOP step-by-step. The commercial laboratories will provide certified sterile sample bottles. If bottle sterility is questionable, the sampler must deface the label or write on the bottle “non-sterile” when no label is attached and put it aside. When temperature of sample measured at the lab is above 20°C, sample analysis will be refused by the laboratory. Improper sampling technique may be detectable from too high standard deviation between replicates. Statistical evaluation will be used to examine the data for outliers.

5.1.3. Cross-contamination from sampling equipment is greatly reduced by using the direct sampling method (collection of samples directly into the sterile container). If the sampler accidentally touched the inside of the bottle, he/she must not use it.

### **5.2 Quality Assurance/Quality Control Samples**

5.2.1 “Field Blanks” will be processed at every sampling day along with the regular samples. For that purpose, sterile buffered water is taken into the field in a sealed container. Two sterile sampling containers will be filled with it at the sampling site. They will be marked according to the code of “Field Blank” and sent to the laboratory to be analyzed with the regular samples. Analysis should result in "0" bacteria counts for blanks (errors, contamination). See procedure under 2.7. Field blanks will be processed close to the end of sampling events for the day.

5.2.2 “Field Replicates” and “Matrix Spikes” will be prepared for each method during every sampling day, which will produce a minimum of one replicate and one matrix spike for every 20 samples. Water will be collected in a 1 liter bottle and then

distributed among four 250mL bottles. Two of the four bottles will be spiked, the other two will serve as field replicates. Field replicates and matrix spikes will be analyzed with the regular samples. Replicates should have comparable bacteria counts (precision of sampling and analysis). See procedure under 2.6 for field replicate sampling.

5.2.3 Temperature will be checked and documented upon arrival at the laboratory. Pistol-grip infrared thermometers are used in both laboratories that allow for touch-free measurement of cooler and bottle temperature. Their accuracies are 1% what is  $\pm 2^{\circ}\text{F}$  or  $\pm 1^{\circ}\text{C}$ . Once releasing the button, readings display for 7 seconds which allows time to record data.

5.3 QA/QC Procedures: Implementation of the QA/QC procedures for surface water evaluation will be established through the following steps:

5.3.1 Ensure that each field team member is familiar with the provisions of the QAPP. The Water Project Manager will ensure that each field team member is familiar with the field sampling SOPs and QAPP prior to implementation of field activities.

5.3.2 The Data Quality Manager, with the assistance of the Water Project Manager, will regularly perform a QA review of field activities, field data sheets and forms to ensure that all procedures are followed.

5.3.3 The Data Quality Manager will verify that all laboratories contracted have a written description of their QA activities and a QA plan describing the QA management of day-to-day routine operations.

5.3.4 The laboratories contracted to evaluate samples are required to adhere to defined quality assurance procedures to ensure that generated analytical data is scientifically valid and are of known and acceptable precision and specificity.

5.3.5 Quality control charts will be maintained for every parameter measured for the study including blanks, calibration factors, and measures of precision for each parameter. The Data Quality Manager will initially perform weekly reviews and specify corrective action as needed. Once acceptable performance is established, this review will be conducted monthly or more often if needed.

## **6. Instrument/Equipment Testing, Inspection, and Maintenance**

Equipment maintenance and repair will be performed as required for each instrument. Preventive maintenance for all equipment includes inspection before use, cleaning as necessary during use, and thorough cleaning and inspection after use. Rechargeable batteries are checked before use and recharged after use. For equipment using disposable batteries, replacement batteries will always be stocked. Maintenance and repairs will also occur when corrective action needs are identified. If the instrument cannot be repaired or recalibrated, the instrument will be replaced.

### **6.1 Corrective Actions**

Corrective actions involving field instruments, including pH, turbidity, DO and temperature will be implemented by the UIC field personnel and documented in field logs. Corrective actions for the analytical laboratory may include the following:

6.1.1 Reanalyzing the samples if holding time criteria permits;

6.1.2 Re-sampling and re-analyzing;

6.1.3 Evaluating and amending sampling procedures, and/or evaluating and amending analytical procedures; and

6.1.4 Accepting the data and acknowledging the level of uncertainty.

## **7. Instrument/Equipment Calibration and Frequency**

Each instrument will be calibrated following the specific manufacturer's recommendations. Laboratory instruments should be calibrated prior to each use or on a scheduled, periodic basis as specified in the analytical methods. Analyzing laboratories both provided documentation of their equipment/instrument calibration data.

Typical microbiology lab instruments/equipment:



<b>Item</b>	<b>Action</b>	<b>Frequency</b>	<b>Accuracy</b>
Bench surface	Monitor for contamination	Weekly	-
Thermometers	Check accuracy	Semiannually	0.1° C
Balances	Service and recalibrate	Annually	
Balances, weights	Check accuracy	Monthly	
pH meters	Standardize	Each use	0.1 pH value
Autoclave	Check performance	Monthly	
Refrigerator	Check temperature	Daily	
Freezer	Check temperature	Daily	
Incubator	Check temperature	Twice daily	
Air in workplace	Monitor bacterial density	Monthly	
Dilution water bottle	Check pH and volume	Each use	

**Table 12: Microbiology lab equipment monitoring**

## **8. Inspection/Acceptance of Supplies and Consumables**

Commercial water quality laboratories (EnviroTest/Perry and SMI) have established rigorous QA/QC systems for all aspects of microbiologic analyses. Copies of their log-books for rinse/dilution water sterility and quality (pH, conductivity, chlorine residual) checks, media storage and preparation, media performance check, membrane filter acceptance QA and copies of other documentation are available for us (and we have copies of pages from those log books)

### **8.1 Dilution/Rinse Water Sterility Check**

Prepared rinse water needs to be checked for sterility on a per lot basis prior to use. The sterility check is accomplished by adding 50ml water to 50ml of a non-selective broth and incubating the mixture. The absence of growth indicates sterility. Water failing the sterility check is re-sterilized (and re-checked) or disposed. Table 13 below presents information about the sterility checks, their monitoring frequency, and their acceptable limits.

Test	Monitoring Frequency	Maximum Acceptable Limit
Heterotrophic Plate Count	Monthly or for new source	<1000cFU/mL, Student's $t \leq 2.78$
Conductivity	Continuous or each use	>0.5megohm resistance or <2 $\mu$ mhos/cm @ 25 °C
pH	Each use	5.5-7.5
Total Organic Carbon (TOC)	Monthly	< 1.0 mg/L
Heavy metals, single (Cd, Cr, Cu, Ni, Pb, Zn)	Annually (more frequently if problematic)	< 0.05 mg/L
Heavy metals, total	Annually (more frequently if problematic)	< 0.1 mg/L
Ammonia/organic nitrogen	Monthly	< 0.1 mg/L
Total Chlorine Residual	Monthly or with each use	< 0.01 mg/l

**Table 13: Quality of reagent water used for microbiology testing [8]**

### 8.2 Media Sterility Check

New lots of media received from the vendor as well as new batches of media prepared in the lab need to be evaluated prior to use. Positive and negative controls are analyzed. The positive control uses a culture that is intended to be the detected analyte of the procedure. The negative control uses a culture that is not intended to be the detected analyte of the procedure. Unacceptable lots/batches cannot be used for the analysis of samples.

### 8.3 Positive/Negative Controls

The method blank is a negative control that goes through all applicable analytical steps and is used to document non-contamination of the analytical process. This control uses sterile buffered dilution water to verify the sterility of the media, equipment and techniques used to process environmental samples in a particular batch. The method blank is considered a batch control parameter. Samples associated with a method blank indicating high bias must be re-prepared and analyzed (if possible).

The lab control sample is a positive control that goes through all applicable analytical steps. This control uses a known culture to verify the ability of the entire analytical procedure (i.e. media, equipment and techniques) to properly identify the presence of the target organism in a particular batch of environmental samples. The lab control sample is considered a batch control parameter. Samples associated with a failing lab control sample must be re-prepared and analyzed (if possible). Where reanalysis is unavailable, the data reported to client is associated with a narrative explaining the QC failure.

#### 8.4 Media Storage

All opened containers of dehydrated media are stored at room temperature in a desiccator unless otherwise recommended by the manufacturer. All prepared media is stored at 4 degrees C in an appropriate container until expiration date.

#### 8.5 Filtration Unit Sterilization

Filtration units are sterilized using an autoclave. A thermometer is used to verify the appropriate temperature of the autoclave environment. Additionally, sterilization tape is used to indicate proper operation of the autoclave. Method Blanks (MBLKs) are processed on each filtration unit prior to the first client-submitted sample as well as after every 10 samples and the last sample. The results from these blanks are used to assess and indicate clean filtration units prior to use on samples as well as throughout an in-going run.

### **9. Non-Direct Measurements**

Meteorology data will be obtained for the sampling sites from the closest stations.

### **10. Data Management**

Field data sheets need to be inspected by the sampler for completion/correct information and given to the Water Project Manager at the end of sampling day or on the following day in case of late afternoon sampling. The Water Project Manager will review it for errors and store them in a locked room. Water quality parameters will be entered in an excel spreadsheet.

Laboratory analyses data for indicator organism will be received by the Water Project Manager.

## **C. ASSESMENT AND OVERSIGHT**

### **1. Assessments and Response Actions**

Reviews of data quality will be performed regularly, as outlined in the system-wide quality management plan (QMP). This project includes several streams of quality monitoring data, and we will use a graded approach to review them.

1.1 At weekly quality reviews, we will note and develop ways to prevent deviations in the protocol that have occurred in the preceding week. This could include:

- rejection of samples by analytic laboratories
- intervals between sample collection and analysis that exceed 6 hours
- field blanks with quantifiable amounts of E. coli or enterococci
- Failure to collect samples at the correct locations or other breaches in protocol

1.2 At monthly quality reviews, summary statistics of field blanks, split samples, and internal laboratory QC data will be reviewed. Summaries of mean densities of indicator organisms by sampling location (CAWS vs. general use waters) will be reviewed and outliers will be identified and reviewed.

1.3 At annual quality reviews, all quality data will be reviewed, as will summaries of indicator and pathogen measures. Emphasis will be placed on system-wide quality issues, with the goal of developing quality improvement strategies for the next recreation season.

## **D. DATA VALIDATION AND USABILITY**

### **1. Data Review, Verification and Validation**

Reduction of analytical results will be done using calculations recorded on analytical data sheets. The laboratory QA manager will verify that the appropriate analytical method is followed and the data are calculated properly. The laboratory QA Manager or his/her designee will validate the data by comparing the raw data to the reported results. In addition, the results of calibration and internal QA/QC checks will be compared with the project acceptance criteria to assess the usefulness of the data. The laboratory analytical reports will contain the following information:

1.1 Raw data, including results of calibration and internal QC checks;

1.2 Analytical data results;

- 1.3 Units of measurement;
- 1.4 Client and sample identification;
- 1.5 Sample analysis dates;
- 1.6 Summary of any problems encountered;
- 1.7 QC data (matrix spikes, blanks, ORPs); and
- 1.8 QA reviewer's signature

## **2. Verification and Validation Methods**

Upon receipt of hardcopy sample results for a monitoring sample, the Water Project Manager will verify that the following information is included:

2.1 Sample result summary sheet, which should include the following:

2.1.1 Sample identification information

2.1.2 Sample result

2.1.3 Laboratory quality control checklist (or other verification from the laboratory that all QC specifications were met)

2.1.4 Method Bench Sheet completed by the laboratory with primary sample processing and analysis data associated with the sample

2.1.5 Laboratory comments. Comments may include any applicable data qualifiers.

The following is a list of potential data qualifiers:

2.1.5.1 Sample arrived at the laboratory in unacceptable condition (i.e., leaking)

2.1.5.2 Sample holding time exceeded

2.1.5.3 Sample holding temperature not within acceptable range

2.1.5.4 Unacceptable blank sample result

2.1.5.5 Unacceptable positive or negative control result

2.1.5.6 Media sterility checks were not acceptable

2.1.5.7 Method incubation times or temperatures were not within acceptable range

2.1.5.8 Membrane filtration: Too much sediment on the filter

2.1.5.9 Membrane filtration: Confluent growth of non-target organism

2.1.5.10 Membrane filtration: Colonies too numerous to count (TNTC)

2.1.5.11. Membrane filtration: Pre- or post- filtration series sterility check not acceptable

If laboratory forms are missing, incomplete, or incorrect, the Water Project Manager will contact the laboratory project manager immediately to discuss and request resubmission of the missing forms and/or spreadsheets.

## **References**

1. Geosyntech Consultants. 2008. Dry and wet weather risk assessment of human health impacts of disinfection versus no disinfection of the Chicago Area Waterways System (CWS).
2. Lee, J. V., S. R. Dawson, S. Ward, S. B. Surman, and K. R. Neal. 1997. Bacteriophages are a better indicator of illness rates than bacteria amongst users of a white water course fed by a lowland river. *Water Sci Technol* 35(11-12):165-170.
3. Love, D. C., and M. D. Sobsey. 2007. Simple and rapid F+ coliphage culture, latex agglutination, and typing assay to detect and source track fecal contamination. *Appl Environ Microbiol* 73(13):4110-8.
4. Noble, R. T., S. M. Allen, A. D. Blackwood, W. Chu, S. C. Jiang, G. L. Lovelace, M. D. Sobsey, J. R. Stewart, and D. A. Wait. 2003. Use of viral pathogens and indicators to differentiate between human and non-human fecal contamination in a microbial source tracking comparison study. *J Water Health* 1(4):195-207.
4. U.S. Environmental Protection Agency, ERT, 1994. Surface Water Sampling, SOP#: 2013 (11/17/94)
- 5 U.S. Environmental Protection Agency, ERT, 1994. General Field Sampling Guidelines, SOP#: 2001 (08/11/94)
- 6 U.S. Environmental Protection Agency, R&D, 1978. Microbial Methods for Monitoring the Environment, Water and Wastes, EPA-600/8-78-017 (Edited by R. Bordner and J. Winter)
- 7 U.S. Environmental Protection Agency, ERT, 1992. Performance Evaluation (PE) Samples, Quality Assurance Technical Information Bulletin (May 1992)
8. U.S. Environmental Protection Agency, ERT, 1992. Quality Assurance/Quality Control Samples, Quality Assurance Technical Information Bulletin (May 1992)
9. U.S. Environmental Protection Agency, ERT, 1995. Superfund Program, Representative Sampling Guidance, Volume 5: Water and Sediment, Part I; Surface Water and Sediment, December 1995

10. U.S. Environmental Protection Agency, NRMRL, 2007. EPA 625/R02/017: Time Relevant Beach/Recreational Water Quality Monitoring and Modeling, January 19th, 2007
11. APHA-AWWA-WPCF: Standard Methods for the Examination of Water and Wastewater, 21st Edition, 2005: Part 9000: Microbiological Examination
12. U.S. Environmental Protection Agency, OWOW, 1997. Monitoring and Assessing Water Quality, Volunteer Stream Monitoring: A Methods Manual EPA 841-B-97-003
13. U.S. Geological Survey. 2003: National Field Manual for the Collection of Water-Quality Data: Chapter A7: Biological Indicators (7.1.2A: Surface Water collection 11/2003)
14. MWRDGC R&D Department (Report No. 05-15) Interim Report, Fecal Coliform Densities in Chicago area Waterways during dry and Wet Weather 2004
15. MWRDGC: Interim Phase I Dry Weather Risk Assessment of Human Health Impacts of Disinfection vs. No Disinfection of the Chicago Area Waterways System (Project No. CHE8188) 2006 November
16. Prepared by Research Triangle Institute, U.S.EPA Contract 68-D4-0091 (August 24, 1999): Data Quality Objectives and Statistical Design Support for Development of a Monitoring Protocol for Recreational Waters, Final Report.



**CHEERS: THE CHICAGO HEALTH,  
ENVIRONMENTAL EXPOSURE, AND  
RECREATION STUDY**

**Quality Assurance Project Plan 2:  
Survey Methods**

**Title and Approval Sheet  
July 29, 2008**

University of Illinois at Chicago School of Public Health  
Division of Environmental and Occupational Health Sciences  
Division of Epidemiology and Biostatistics  
2121 W. Taylor St., M/C 922  
Chicago, IL 60612



7/30/08

---

Samuel Dorevitch, MD, MPH  
Study Director

Date

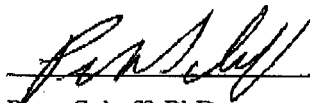

---

Peter Scheff, PhD  
Quality Manager

7/29/08

Date

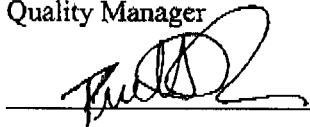

---

Preethi Pratap, PhD  
Survey Project Manager

7/30/08

Date

## **Table of Contents**

<b>A. PROJECT MANAGEMENT</b>	<b>1</b>
1. Distribution List	1
2. Project/Task Organization	1
3. Problem Definition/Background	4
4. Project Task/Description	5
5. Quality Objectives and Criteria	6
6. Special Training/Certification	6
7. Documents and Records	8
<b>B. DATA GENERATION AND ACQUISITION</b>	<b>11</b>
1. Sampling Process Design (Experimental Design)	11
2. Sampling Methods	11
3. Sample Handling and Custody	31
4. Analytical Methods	31
5. Quality Control	33
6. Instrument/Equipment Testing, Inspection, and Maintenance	37
7. Instrument/Equipment Calibration and Frequency	37
8. Inspection/Acceptance of Supplies and Consumables	37
9. Non-direct Measurements	39
10. Data Management	40
<b>C. ASSESSMENT AND OVERSIGHT</b>	<b>42</b>
1. Assessments and Response Actions	42
2. Reports to Management	43
<b>D. DATA VALIDATION AND USABILITY</b>	<b>44</b>
<b>References</b>	<b>45</b>
<b>List of Tables</b>	<b>ii</b>
<b>List of Figures</b>	<b>ii</b>
<b>List of Appendices</b>	<b>iii</b>

### **List of Tables**

<b>Table</b>	<b>Description</b>	<b>Page</b>
Table 1	Index of Documents and Records, Storage and Distribution	9
Table 2	Composition of Field teams	20

### **List of Figures**

<b>Figure</b>	<b>Description</b>	<b>Page</b>
Figure 1	Overall Project Management Structure for Survey Methods	3
Figure 2	Field Team Management Structure	20

## List of Appendices

<b>Appendix</b>	<b>Description</b>
1A-P	CHEERS Survey Training Manual
2	EPA/CDC NEEAR Study Beach Survey
3	EPA/CDC NEEAR Telephone Interview
4A-B	Eligibility Screener & Refusal Tally
5	Field Survey A
6	Field Survey B
7	Follow-up Telephone Interview
8A-E	CHEERS Pilot Study protocol and IRB approval letter
9	Use Survey Data Sheet
10	IRB Exemption for user survey
11	IRB approval for CHEERS Survey Methods Protocol
12	Thermal wristband bar coding technology
13	CHEERS Survey Methods Field Report
14A-U	Maps of recruitment areas
15	CHEERS Location Specific Flyer
16	Adult Consent Form
17	Parental Consent Form
18	Assent Form
19	Questionnaire Variables for Data Analysis

## **A. Project Management**

### **1. Distribution List**

UIC: S. Dorevitch, P. Scheff, M. Javor, P. Pratap, S. Wuellner, A. DeLaquil, J. Wuellner, T. Schoonover and all other CHEERS staff.  
MWRDGC: T. Granato

### **2. Project/ task organization**

Figure 1 outlines the lines of authority linking key members of the CHEERS study involved in the questionnaire development and project implementation. The study director will have overall authority in the development and implementation of the study questionnaires and hiring of project managers involved in recruiting and survey administration. The quality manager will establish overall data quality objectives for the CHEERS study and will be in charge of reviewing the quality of the data and the questionnaire data collection process. The detailed organizational structure is provided in the Study Overview.

The Survey Project Manager (SPM), Preethi Pratap, PhD, has primary responsibility for the development and implementation of the study survey questionnaires, hiring and monitoring of field interviewers and recruiters, communicating with the Survey Research Laboratory (SRL), and maintaining the overall quality of the field data collection and management process. The Survey Project Manager, with assistance from the Assistant Survey Project Manager (A-SPM), is responsible for the following project related tasks:

- 2.1. Develop the study questionnaires and conduct necessary pilot tests and reviews in order to improve and ensure quality of these questionnaires and the field data collection methods.
- 2.2. Obtain Institutional Research Board (IRB) approval for the use of the study questionnaires in the field and data collection methods.

- 2.3. Work with the University of Illinois at Chicago (UIC) Survey Research Laboratory (SRL) to program and review the study questionnaires.
- 2.4. Work with the project manager to recruit and hire data managers and interviewer-recruiters.
- 2.5. Develop, implement, and evaluate training programs for field data managers and interview-recruiters.
- 2.6. Ensure all field team members involved in recruiting and survey administration are certified (and maintain certification) by the UIC IRB for Human Subjects Research.
- 2.7. Work with the SRL to develop and conduct the appropriate training methods to administer the questionnaires.
- 2.8. Ensure all field team members involved in recruiting and survey administration are trained in questionnaire administration and interviewing techniques before they begin recruiting in the field.
- 2.9. Implement adequate quality control methods during field events to ensure accurate compilation of consent documents, assignment of Case IDs for study participants, and the smooth flow of participants through the study process.
- 2.10. Meet regularly with survey data managers to review and, when possible, improve the field work conducted by the interviewer/recruiters.
- 2.11. Securely transfer data to SRL after each field event.
- 2.12. Assist the Project Manager to staff the field events. Assist the Clinical Manager, when necessary, to ensure timely clinical specimen collection or pickup.
- 2.13. On a weekly basis track study enrollment and data collection of the CHEERS study, including study completion by participants, and attrition from the study.
- 2.14. Provide timely feedback and reports to the CHEERS study quality manager and study director throughout the data collection process.

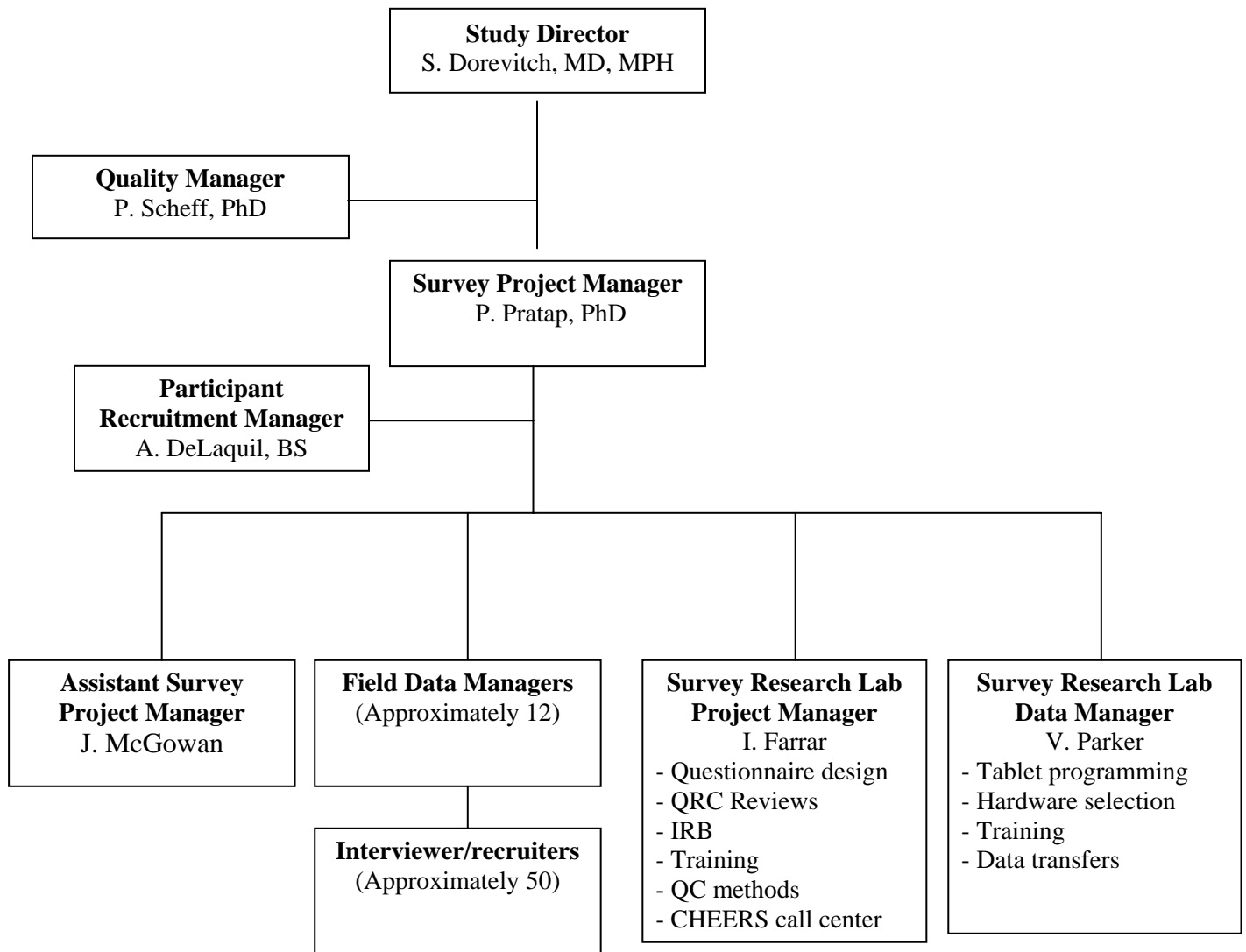

**Figure 1: Overall Project Management Structure for Survey Methods.**

### **3. Problem Definition/Background**

The overall scientific background and goals of the CHEERS study are outlined in the Study Overview document. The following sections will focus on the development, implementation and use of the CHEERS questionnaire data collection methods.

In order to meet the following study objectives:

- 3.1 To determine rates of acute gastrointestinal and non-gastrointestinal illness attributable to recreation on the Chicago Area Waterways System (CAWS)
- 3.2 To define the relationship between concentrations of microbes in the water and rates of water illness among recreators

It is necessary to:

- define participant demographics, non-water-related risk factors for illness, other water exposures, and health end-points
- ensure that the survey questionnaires are easy to follow and complete
- characterize usage at CAWS recruiting locations
- use available technology for reliable recording of responses in a timely fashion
- develop a system for assigning unique participant ID and be able to track their progress throughout the study
- develop a secure and reliable method for transferring data from the field to SRL
- have a system in place for tracking participant completion of study elements and attrition rates
- construct a database of the survey data



#### **4. Project/Task Description**

The overall project objectives are:

- 4.1. To develop CHEERS study questionnaires
- 4.2. Work with SRL to program the questionnaires into portable computers and desktop computers
- 4.3. Ensure all project staff are IRB certified, and trained in survey administration and interviewing techniques
- 4.4. Conduct a pilot study in order to evaluate and refine the study questionnaires prior to use in the field
- 4.5. Conduct a user survey to identify potential sampling locations for CHEERS study recruitment
- 4.6. Obtain IRB approval (pilot and final epidemiologic study) for use of study questionnaires and the data collection methods involving human subjects
- 4.7. Establish the field study base of operations on day of event
- 4.8. Provide advance and day-of-event publicity
- 4.9. Screen interested individuals for eligibility
- 4.10. Enroll those who are eligible through the informed consent process
- 4.11. Administer survey questionnaires prior to and after recreation
- 4.12. Transfer and receive data through secure channels to/from SRL at the end of each event
- 4.13. Conduct follow-up telephone interviews
- 4.14. Coordinate the above with clinical specimen collection and collection of water samples
- 4.15. Implement QA/QC methods throughout the data collection and management process
- 4.16. Provide field reports and quality reports to the study director and quality manager on a regular basis
- 4.17. Track progress of participant enrollment and completion of study
- 4.18. Analyze data to improve and refine the data collection process and recruiting methods

The proposed dates and locations of various recruiting events are outlined in Study Overview.

## **5. Quality Objectives and Criteria**

The overall quality objectives are:

- 5.1. To develop appropriate data collection methods to gather high quality data that can be used to test the hypotheses of the study described in the Study Overview
- 5.2. To ensure all CHEERS personnel will receive proper training and oversight
- 5.3. To maintain integrity of data at all times during data collection and data transfer from field/phone to final dataset
- 5.4. To ensure that 100% of the participants who complete the field surveys will receive a follow-up telephone call on days 2, 5 and 21 of the study

## **6. Special Training/Certification**

As per the University of Illinois at Chicago (UIC) Institutional Review Board (IRB) all UIC Investigators and key research personnel in the CHEERS study are required to meet the training requirements in human subjects protections before their involvement in any research involving interactions with human subjects (including the publicity and recruitment process, consent process, administration of surveys and telephone interviews). No CHEERS study personnel will be allowed to participate in research activities involving human subjects until they have, and maintain, IRB certification.

All CHEERS personnel involved in recruiting and survey administration or any human subject interaction in the field will be required to obtain IRB certification in Biomedical Research at UIC. The SPM is responsible for maintaining a log of the IRB certification status of all CHEERS study personnel at all times during the study. Study personnel will be reminded about the expiration of their IRB certification status at least 2 months in advance, and if necessary, provide information as to how to take the online training. Any study personnel with an expired IRB certification status will not be allowed to participate in field activities involving human subjects.

In order to be eligible to recruit participants, administer survey questionnaires, and conduct telephone interviews all CHEERS study personnel will also be required to complete an in class training session designed and conducted by the SPM with assistance from SRL.

The training will cover all documents included in the training manual (Appendix 1). Many training documents from the EPA/CDC NEEAR study were adopted and revised. In addition CHEERS study personnel will also complete the following:

- An on-line general recruiting and interviewing training session designed by SRL
- A power-point presentation of the CHEERS study overview
- A power-point presentation outlining a day in the field, including:
  - An introduction to survey questionnaires
  - An introduction to interviewing techniques, “Do’s” and “Don’ts”
  - How to approach participants and recruit them
  - How to check participant eligibility
  - How to conduct the consent process
  - How to administer the CHEERS survey questionnaires (including use of hand-held computers in the field and telephone interviews on a desktop computer)
  - How to hand out incentives in the field
- Mock interviews - These are conducted in groups or one-on-one. The SPM, SRL staff, and/or A-SPM will conduct these mock interviews. We will go through each of the surveys question by question. The mock interviews will focus on:
  - Probing methods
  - Recording the answers correctly
  - What to do if problems arise

The SRL Project Manager and the SPM will plan and conduct an in-class training session prior to each recreation season.

All new CHEERS personnel hired for the study will complete an in-class training session (including the mock interviews) under the guidance of the SPM or any other staff member identified by the SPM. When the new hire is conducting a mock interview, the SPM or other designated staff member will note any problems with the administration of the questionnaire, as well as any misclassification of responses.

## **7. Documents and Records**

The development and use of all CHEERS documents and records related to Survey Methods has been outlined in Section B of this document. The following Table 1 identifies these documents and records, the personnel responsible for record keeping and the study personnel who will receive copies of these documents.

Only the study director, the SPM, and SRL project staff will have access to raw data. Study personnel will be IRB trained to treat data confidentially. Several levels of protection minimize risks of disclosure to others in order to protect confidentiality of participants. The consent forms which will contain both the name and unique Case ID for each participant will be kept in a locked cabinet in a pre-assigned CHEERS office. De-identified data (only with Case ID) will be stored in a computer at the study director's office, SPM office, and SRL. Only de-identified datasets will be made available to CHEERS staff (such as the study biostatisticians) involved in data analysis. All computer data files will be password protected during transfer.

Only consent documents and contact-tracing forms will contain participants' names and Case ID. All other study-related forms/data will contain the Case IDs only. A master file linking the Case ID and participant names will be stored in a password protected computer file. Nothing in this file will indicate participant characteristics, responses or results.

All data without personal identifiers will be retained for an indefinite period. The master files linking names and Case IDs will be destroyed 6 years after completion of the study. No audio or video tapes will be made of research subjects.

**Table 1. Index of Documents and Records, Storage and Distribution**

<b>CHEERS Study Documents and Records</b>	<b>Personnel Responsible for developing and storage</b>	<b>Storage Type</b>	<b>Distribution List</b>
QAPP # 2 with appendices.	SPM	Computer file Hard copy	- All CHEERS study personnel - MWRDGC liaison
IRB certification/Training completion status for personnel	SPM	Computer file Log book	- SPM - Study director
CHEERS survey training manual	SPM	Computer file Hard copy	- SPM - A- SPM - Study director - Data managers - Interviewer/recruiters
SRL phone/ call center training manual	SRL/ SPM	Computer file Hard copy	- SPM - SRL - Study director - Call center staff
BLAISE technical manual	SRL / SPM	Computer file Hard copy	- SPM - A-SPM - All CHEERS Field personnel
Field Supply Checklists	SPM/Project Supply Manager	Hard copy will be stored in a file folder	- Project Supply Manager - SPM - All Field event coordinators
Equipment Maintenance	SPM/ SRL	SRL record	- SPM - Assistant SPM - Study director - Data managers - SRL - Supply managers
Field Report	SPM/A-SPM	Hard copy will be stored in a file folder	- Quality Manager - Study Director
Call center reports	SPM/SRL	Computer file Hard copy of reports will be stored in a file folder	- SPM - A-SPM - SRL - Study Director

			- Quality manager
Field Recruitment/Attrition reports	SPM/SRL	Computer File Hard copy reports stored in a file folder	- SRL - SPM - A-SPM - Study Director
Paper-based forms (consents)	SPM/A-SPM	Copied and stored in a secure file folder or locked cabinet	- SPM - Study Director
Gift card receipt book/ T-shirt checklist	SPM/ Project Manager/ Project Supply Manager	Stored in the Program Coordinators Office	- Project Manager - SPM - Project Supply Manager - Supply manager - Field Supervisors - Data Managers - Incentives staff

## **B. Data Generation and Acquisition**

### **1. Sampling Process Design**

The study design, sample size calculations, sampling locations and rationale for design are outlined in the Study Overview document. The following sections will focus on the development, implementation and use of the CHEERS questionnaire data collection methods.

### **2. Sampling Methods**

#### 2.1. Development of CHEERS study questionnaires

The CHEERS study questionnaires developed for this study are derived from those used in the National Epidemiological and Environmental Assessment of Recreational Water (NEEAR) study, conducted by the US EPA and CDC (NEEAR Study Beach Survey and Telephone Interview, Appendix 2 and 3). Like the NEEAR study, we will use surveys to conduct pre-exposure health assessments, post-recreation exposure assessments, and post recreation health follow-up by telephone. Modifications to the NEEAR approach are: 1) the unit of recruitment (and interviewing) will be individuals, rather than family groups, and 2) exposure questions specific to secondary contact recreational activities have been added.

A total of five CHEERS study questionnaires will be administered:

- 2.1.1 Eligibility screener and refusal tally sheet (Appendix 4)
- 2.1.2 Field Survey A (Appendix 5)
- 2.1.3 Field Survey B (Appendix 6)
- 2.1.4 Follow-up Telephone Interview (Appendix 7)
- 2.1.5 Home Clinical Evaluation Form (Described in QAPP# 3, Clinical Evaluation)

## 2.2 Survey Research Laboratory Computer Assisted Interviewing System

The CHEERS study questionnaires have been developed in conjunction with the University of Illinois at Chicago (UIC) Survey Research Laboratory (SRL), a national leader in survey development, administration, and analysis. Field Surveys A and B will be administered as face-to-face interviews, with the exception of the telephone follow-up interview, which will be administered by telephone. The questionnaires will be administered using computer assisted interviewing (CAI) methods, with the exception of the eligibility screener and the home clinical evaluation, which will use paper forms. The CAIs conducted in the field will be administered using computer assisted personal interviewing (CAPI) methods, while the telephone follow-up questionnaire will be administered using computer assisted telephone interview (CATI) methods. Field interviews will be conducted using tablet computers and the telephone interview will be conducted in a call center at UIC SRL using desktop computers.

We have chosen to use CAI methods for administering the questionnaires rather than traditional paper and pencil techniques as CAI methods are known to enhance the quality of survey data in a number of ways:

- Routing problems (or skip patterns) within the questionnaire are eliminated.
- Interviewers cannot miss questions or ask the wrong questions.
- Questions are 'customized' correctly for each individual. For example, if a participant's recreational activity is "fishing," questions will be asked about number of fish caught, type of bait used, etc.
- Information from one question can be carried out within the program or dates can be populated for one question using information from a previous question.
- The computer checks for inadmissible or inconsistent responses.
- Data is entered one time, rather than two (in the field on paper and manually entered into a computer site at the study center). This elimination of a data entry step prevents errors.
- Facilitate the fast turn around of data for the follow-up telephone interviews and home visits.



SRL uses the Blaise CAI system developed by the Statistics Netherlands. Version 4.7 will be used for this study. This system functions on a Novell Network and is based on a shareable storage device. It also works on notebooks and tablet computers for on-site interviewing needs. Computing power and random access memory are located at each “intelligent” interviewing station. The CAI software (a) simplifies the sign-off or start-up procedures between the interviewing station and the network; (b) provides temporary back-up storage for the data produced by an interview, in the event that the connection to the network fails, is busy, or malfunctions or in the event of power and operating system errors on notebooks; and (c) stores and executes the questionnaire text and administration logic per programmed specifications.

The system also facilitates recoding of closed- or open-end text answers, execution of real-time and post data collection consistency and range checks, complex branching and calculations, and production of data files formatted for use with several popular statistical analysis packages.

SRL’s Office of Survey Systems (OSS) works with the computer-related aspects of interviewing. OSS contributes to the design and programming of software to schedule, screen, track, and conduct computer assisted interviews. After the data collection period, staff members will produce and run cleaning programs on closed-ended variables and produce composite variables as necessary. They will also produce a final dataset in SAS format.

## 2.3 Evaluation of study questionnaires

The overall objective is to evaluate and refine the field and telephone questionnaires to be used in the CHEERS Study. Specific aims are to:

- Evaluate question wording for problems of comprehension and sensitivity
- Estimate the time and difficulty of completing the questionnaires
- Evaluate question order to minimize potential satiation and or non-response
- Identify potential problems with the administration of the questionnaires
- Identify improved methods for recruiting study participants
- Identify improved methods for evaluating water contact for several water recreational activities

### 2.3.1. SRL Questionnaire Review Committee

In order to produce high quality data it is necessary to make sure that the questionnaires ask the right questions in the right way, and are user friendly. The CHEERS study questionnaires were reviewed by an infectious disease epidemiologist, an environmental epidemiologist, and an industrial hygienist at the UIC School of Public Health.

Following questionnaire development, each questionnaire was reviewed by members of SRL's Questionnaire Review Committee (QRC). This committee, composed of technical experts within SRL, reviews all survey instruments at their pretest and final stages to ensure that approved ethical practices are maintained and that basic principles of questionnaire construction are followed. No instrument is administered to respondents before approval is obtained from this committee.

The QRC members have extensive experience related to questionnaire construction. The QRC review ensures that this expertise is applied to each SRL instrument regardless of which staff member has drafted it. To this end the committee reviews each instrument with the following kinds of concerns in mind:

- Is the ordering of the questions appropriate?
- Does the ordering present any possible problems of context effect?
- Does the ordering meet the needs of the science while minimizing respondent burden and optimizing cooperation?
- Are all of the questions necessary? Should any be added?
- Are the response options appropriate?
- If response categories are given, are they consistent with the question, understandable to the respondent, and least likely to invoke socially desirable answers?
- Are the vocabulary and constructs in the questions comprehensible to the respondents?
- Is it reasonable to expect that the respondents have the knowledge or memory required to answer the questions?
- Are sensitive questions constructed to limit, as much as possible, less-than-truthful responses because of social desirability?
- Are there design or format questions remaining that might require the use of cognitive methodologies, such as focus groups or think-aloud interviews prior to typical pretesting?

Before instruments are used in the field, they are tested in-house. In the case of computer-assisted telephone interviews like the proposed study, the CHEERS field staff will conduct extensive testing of the computer programming to test the questionnaire logic during the SRL training session and pilot study. This allows for evaluation of all skip patterns and contingencies that are programmed into the questionnaire and avoids the awkward situation that occurs when an interviewer encounters a problem while trying to keep a respondent on the telephone.

### 2.3.2. Pilot Field Testing

In addition to expert review of the study questionnaires, pilot field testing is highly recommended to maximize the ability to refine the questionnaires for validity. Although the CHEERS questionnaires were developed using the EPA/CDC NEEAR study survey, the modifications had not been tested in the field. Additionally, the study wants to avoid asking potentially troubling or uncomfortable questions.

Prior to the field launch of the epidemiologic study, a pilot study was conducted to solicit reactions from respondents on the questionnaire length, difficulty in comprehension, sensitivity of questions asked, any wording problems, gauge the appropriateness of the questions and the validity of the responses. In addition, the pilot work also assisted in debugging the questionnaire administration process. The pilot data helped refine the final version of the questionnaires to be used in a larger field study.

The CHEERS Pilot study protocol was submitted to the UIC IRB, along with a copy of all the study questionnaires. The IRB approved the CHEERS pilot study. The field pilot study was conducted from July 21- 30, 2007. A detailed description of the pilot study methods, IRB approval letter, and evaluation forms used is found in the 2007 QAPP 2 document (Appendix 8).

## 2.4 Use Survey

This section will describe the use survey that we will undertake to characterize usage so that the activities and locations of recreation among participants enrolled in the CHEERS study can be compared with actual usage patterns. If users who enrolled in the study tend to engage in low-exposure activities, or recreated in areas of relatively low microbe densities, the true risk among users in general may be underestimated. By working to ensure the comparability of the study subjects to the larger population of users, findings about risks of illness due to recreational exposure on the waterways will provide a more accurate estimate of risk among the population of users.

Specific aims of the use survey are to determine:

- Usage, in terms of numbers of users, and types of recreational activities at various access points
- To identify differences in usage between locations
- To identify differences in usage at the same location at different times of day, and different days of the week
- To identify use at informal access points

The procedure of the usage survey will be as follows:

- a. At CAWS recruiting events staff will select a clear view of the access point of interest, preferably in a shaded location. They will fill out the top half of the Use Survey Data Sheet (Appendix 9).
- b. Using the datasheet, staff will tally the number of individuals who begin recreation, by recreational activity. The tally will be done in 10-minute intervals. The first interval will begin at 0, 10, 20, 30, 40, or 50 minutes past the hour. Staff will write into the chart the hour (clock time) for each interval.
- c. In order to avoid counting the same individual more than once, individuals will be counted only when they begin a recreational activity. Those recreating at the time that counting begins will be identified by circling the tally marks for those individuals.
- d. After a datasheet has been completed, staff will begin a second sheet, taking care to again complete the top portion, including the page number.
- e. Safety of the researchers will be maintained at all times. The field study will not be done without adequate light and will be terminated in the event of inclement weather. Researchers will also be instructed to leave the area and seek a safe location in the event that they feel that their safety is threatened in any way.
- f. At the completion of data collection, data sheets will be brought to the UIC School of Public Health and photocopied. One copy will be placed in the mailbox of the SPM, and the other in the mailbox of the study director.
- g. Data will be entered into an excel file.

- h. On two dates per month during the summer months, while the team is at the primary access points at which the study will take place, another pair of staff members will follow the same protocol for one-hour intervals at public access points that are not designated as recruitment sites for the CHEERS study.
- i. Two surveys by boat will be conducted, one on the North Shore Channel / North Branch of the Chicago River and a second survey on the Little Calumet River/ Cal-Sag Channel to identify use at areas not identified on the Public Access Inventory compiled by the MWRDGC.
- j. Schedule and locations: When field teams are conducting the CHEERS study at various locations, one staff member will monitor use.
- k. Consent: Because this is a study of the behavior of anonymous individuals in a public space this study has been granted exempt status by the UIC IRB for the protection of research subjects (Appendix 10). Thus no consent process for the recreational use study is necessary and none will be performed.
- l. Only field staff trained in this protocol will conduct this use survey. When the survey is conducted in isolation (i.e., on days or at locations that participants are not being enrolled in the CHEERS study), staff members will work in pairs. When the survey is conducted at the time and place of the CHEERS study, staff may conduct the survey without a partner.
- m. Data management: Following the field survey, copies of the datasheet will be used to enter the tallies by category into an Excel spreadsheet, which will be converted to SAS format for analyses. These analyses will include:
  - 1. Frequency of each activity
  - 2. Frequency of use by location
  - 3. Frequency of use by activity, by location
  - 4. Differences in use within a location, weekend vs. weekday
  - 5. Differences in use within a location, morning vs. afternoon

These analyses will be conducted by a CHEERS staff member, and data will be stored in a computer file on a desktop computer in the study director or SPM's office.

## 2.5 Field Health Measures Protocol

The pre-event study publicity methods and organizations involved have been outlined in the Study Overview. The CHEERS survey methods protocol, outlined below, was approved by the UIC IRB, (this includes all the study questionnaires, recruitment materials) (Appendix 11). The following section outlines the steps involved in day of event staffing, publicity, recruitment and data collection using the study questionnaires.

### 2.5.1 Day of Event Staffing

The expanded recruiting schedule will require significant increases in staff, including managers of the field teams. The proposed management structure for the field work is presented in Figure 2. At each location (A-D), a morning team and an afternoon team (teams 1 and 2) will operate. The composition of each team is described in Table 2. While each member of the field team will have a primary responsibility, they will be cross-trained, and data managers and recruiters will be able to function as interviewers as need. Likewise, interviewers will be able to recruit potential participants. The structure of teams for large events will be similar, though 2-4 teams may be in the same location.

Responsibilities of field team managers are:

- Project Manager (Sara Wuellner, MS): Responsible for staffing and scheduling field events.
- Survey Project Manager (Preethi Pratap, PhD): Responsible for recruiting and training survey staff, developing and using questionnaires, ensuring the transfer of field survey data to the call center, working with SRL to track completion rates at all phases of the study, and ensuring the collection of high-quality survey data.
- Field supervisors: Assist the SPM in monitoring field work, training field personnel, tracking quality of field data collection, and serve as a resource to field team. Supervisors are responsible for transferring data to SRL at the end of each field event.

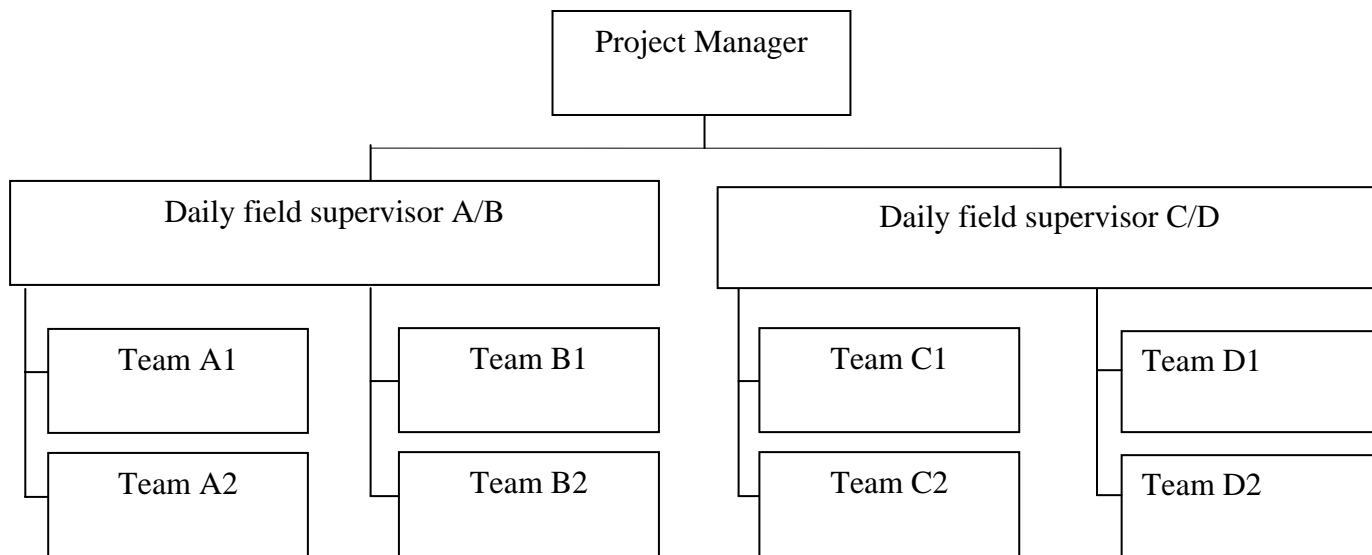

**Figure 2. Field team management structure**

**Table 2. Composition of field teams**

<b>Position</b>	<b>Primary responsibilities</b>	<b>Number per team</b>
Data manager	Consent form tracking, ID/wrist band assignment, tracks return for survey B, downloading data	1
Recruiter	Approaches recreators, passes out fliers, evaluates eligibility	1-2
Interviewer	Conducts field interviews A and B; distributes T-shirts, gift cards, obtains signature on cash receipt, provides stool collection instructions.	1-4
Use survey	Records the number of waterways users	1 (CAWS only)

**Note:** Detailed job descriptions of the above positions are provided in the CHEERS survey training manual (Appendix 1)



On the day of the event study personnel will wear CHEERS T-shirts and identification badges. Teams of CHEERS study staff members will work together in a coordinated fashion to conduct the water sampling and questionnaire administration. The field base of operations will be based around a tent prominently displaying the CHEERS study banner. With the cooperation of the MWRDGC, UIC will work with local municipalities and other government entities to arrange all necessary permits for this field work.

The publicity and screening will take place outside of the tent, with study personnel speaking with potential participants nearby. The consent process and administration of surveys will generally take place in the tent. A typical day in the field can range from 8-12 hours. CHEERS staff will work in shifts, at multiple sites. In addition to conducting interviews in the CHEERS tent, we may conduct some mobile recruiting and interviewing. The composition and responsibilities of the field teams will be as follows:

- a. A field manager, who will have overall responsibility for establishing the sites; coordinating the field logistics; allocating vehicles; and the collection and transport of water samples.
- b. A supply manager, who will ensure that all supplies and equipment necessary for recruiting and interviewing study participants arrive on time to each location of field work.
- c. A field supervisor, who will be responsible for the overall administration of surveys, management and security of consent forms and other field documents. The field supervisor is the final authority in making decisions regarding questionnaire administration and assigning interviewer duties. The field supervisor will have responsibility for teams working over two shifts (AM/PM) at two locations. The field supervisor will be in cell phone contact with data managers as needed. The field supervisor will also assist in recruiting, interviewing and managing data as needed.
- d. A data manager, who will receive the paper eligibility and consent forms. The data manager will maintain a log of study participants, assign and record their Case ID (unique identifiers), and place a wristband with that ID number and a bar code version of that ID number, printed in waterproof ink (Appendix 12). The data

manager will also track participant progress through interview process, and will ensure the efficient flow of participants through the process. The data manager will ensure that all computer data files are consolidated and downloaded onto a flash drive following each day of field data collection. The flash drive will be transferred to the supervisor at the end of the day. The data manager will also ensure the proper flow of research participants through each phase of the data collection process. The data manager will work under the direction of the field supervisor and report any unusual events or staff issues to the supervisor as and when they come up. The data manager is responsible to download the data and transfer the files to the supervisor at the end of the day. The data manager will also complete a field report (Appendix 11) at the end of each day. The data manager will hold a briefing prior to each field work shift during which time the recruitment area for the site will be defined and displayed on a map. Interviewer-recruiters, both stationary and mobile (where applicable) will be reminded to approach all individuals recreating within the sampling area.

- e. The field supervisor will collect all the flash drives from the data managers at the end of each day. The data from these flash drives will be secured in a password protected zipped file and emailed to the SRL staff. In addition an email with the details of number of participants recruited for the day will also be sent to SRL.
- f. Two to four interviewers, who will perform event day publicity, evaluate eligibility, take potential study participants through the consent process, and administer Field Surveys A and B. The interviewers may take turns to recruit and interview. In addition some interviewers may work in mobile teams of 2 to recruit participants away from the CHEERS tent. This increases our radius for recruitment.
- g. Water sampling personnel, as described in QAPP # 1.
- h. Many staff members will be cross-trained so that survey staff will be able to participate in recruitment and consent. Similarly, some water sampling staff will be able to conduct surveys. At the beginning of each field session, all staff trained in recruitment and consenting will conduct such activities, and will then assume their other roles (such as survey administration) as participants enroll. Likewise, when a staff member assigned to administer surveys has no participant to interview, they will conduct recruiting.

- i. An incentive provider will be assigned to hand out the T-shirts and gifts cards at each site. All participants will have to sign a receipt book as and when they receive their gift cards. In addition a checklist will be used to record t-shirt distribution. It is the responsibility of the incentive provider to report the final number of receipts to the supervisor on site at the end of each day.

### 2.5.2 Recruitment areas

Recruiting locations are chosen with the goal of efficiently recruiting 9,330 study participants distributed approximately equally among the three groups (CAWS, GUW and unexposed) at locations that provide a range of water quality measures. At a given field site, however, interviewer-recruiters are to approach all recreators within the recruitment area. This is to avoid any bias, conscious or otherwise, that recruiters may have. Within a recruitment area, all recreators (regardless of age, gender, ethnicity, or race) are approached, engaged by study personnel, and if interested, screened for eligibility. Maps of the recruitment areas for specific sites are included in Appendix 14.

### 2.5.3 Day of event publicity

Study personnel will approach individuals within the recruitment area of each site, and work to interest them in participating in this research using a specified recruiting script and a FAQ sheet outlined in the CHEERS survey training manual (See Appendix 1) outlining responses to commonly asked questions. CHEERS team members will approach individuals within the pre-defined recruitment area at the launch sites at access points, piers, harbors, beaches (for lake kayakers), and at nearby running/biking trails, tennis courts, and sports fields. Individuals will be provided with a location specific CHEERS flyer (See example in Appendix 15) before they begin their recreational activity and those interested in learning about the research will be told more about the purpose of the study and what their participation in this research would involve. They will also be given an opportunity to ask any questions. Any

vendors (water-activities or food/water) on site will be requested to pass along the flyers to customers.

#### 2.5.4 Eligibility

Individuals interested in participating in the CHEERS study will answer a series of questions from the paper-based Eligibility Screener, which will determine their inclusion in to or exclusion from the study.

Inclusion criteria are:

- Will be engaging in outdoor recreational activities and will be available for telephone follow-up over the next three weeks
- Intend to return for interview B prior to that day's departure of CHEERS personnel, the time of which will be specified (generally before 8 PM)
- Prior participant who has completed the 21- day telephone survey

Exclusion criteria are:

- Recreational activity on day of enrollment will be swimming, water skiing or tubing
- Are currently participating in the CHEERS study (have not completed day-21 telephone survey)
- Have participated in water recreation in the past 48 hours (not including swimming pools, but including wading in beaches)
- Are not able to complete Survey B in the field, or not willing to participate in telephone follow-up

After the eligibility screener has been completed, individuals who are interested in participating but are not eligible will be notified. Those who are eligible will begin the consent process. Any reasons for ineligibility of participants or refusals will be recorded in the refusal tally sheet (Appendix 4) section of the eligibility screener.

### 2.5.5 Consent

Study personnel will explain to eligible participants 1) what would be asked of them if they agree to participate, 2) that participation is voluntary, and 3) the potential benefits and risks of participation. They will provide a consent document which provides this information in greater detail. After reading the consent document, participants will be given an opportunity to ask any questions they may have about the study. All eligible participants 18 years or older who choose to enroll in this research will sign the consent form (Appendix 16). A parent or guardian will complete a parental consent form on the child's behalf for all participants under the age of 18 years (Appendix 17). All children 7-17 years of age will also be given an assent form (Appendix 18) to complete. All consent forms will be paper-based. Participants in group events organized by Friends of the Chicago River who express interest in participating in the CHEERS study in advance of the event will receive study information and consent documents by e-mail prior to the event.

Eligible participants can enroll in this research as often as every 21 days. Each time they would receive the same set of financial incentives (gift cards and checks) as well as a CHEERS T-shirt. This research study will seek to recruit members of rowing teams and other sports team/clubs several times during the 2008 season. If a child is on a team/club, the parent can check a box on the signature page of the parental consent form that would allow the child to enroll and re-enroll into the study even if a parent is not present. Parents can withdraw their permission at any point by contacting the CHEERS team.

All CHEERS team members involved in recruiting will be certified by the UIC Institutional Review Board (IRB) and all human-subjects research will take place with the approval of the IRB (Appendix 11).

### 2.5.6 Unique identifiers (“Case ID”)

Upon completing the consent process participants will be directed to the field data coordinator, who will take the consent forms, and apply a bar-coded wrist band with a unique Case ID to the wrist of each participant. A second copy will be attached to that particular participant’s consent form. In addition the participants case ID will be logged into a field book. At each survey station a CHEERS staff member will scan the bar-code on the wrist band into a laptop computer (the scanner will be connected through a USB port) and enter the participants name into the form before beginning the surveys. At the end of the data download process each day, SRL will be able to link the data from individual forms by Case ID and name for each participant.

Bar-coding, a form of keyless data entry will allow automatic identification and data collection is commonly referred to as Auto ID (Appendix 12). The motivation to use bar coding is to improve data management and reduce errors related to data entry and tracking. The benefits of bar coding for our study include:

- Improved data accuracy: Scanning a bar-code rather than typing a number is over 99% accurate. With data entry playing such a critical role in this study, it is absolutely necessary for each participant to have a unique ID and for us to be able to link their data from individual forms in the field.
- In addition, it is easier for a participant to have a bar-coded wrist band with their unique case ID than to have a participant remember a case ID number, or to carry a piece of paper with their Case ID when they are recreating.
- The wristbands are durable and water proof and will have to be cut in order to be released. In addition they will serve as a colorful reminder to the participant to return to the tent to complete the survey after their activity.
- Bar-coding reduces the impact of human error and enables users to work faster, without sacrificing accuracy.

### 2.5.7 Field Survey A

Field Survey A (Appendix 5) will be administered in a face-to-face interview by trained personnel. This will take approximately 2-3 minutes.

### 2.5.8 Field Clinical Evaluation

The 2007 QAPP included a plan for conducting a clinical evaluation of study participants in the field on the day of enrollment. After conducting the field clinical evaluation on first 130 participants in August, 2007, little useful information was gleaned (findings were limited to bug bites and allergic conjunctivitis). Given the low yield of this component of the study and the recommendations of the WERF peer review panel, the field clinical exam was deleted from the CHEERS protocol in September, 2007.

### 2.5.9 Field Survey B and exit protocol

- a. After participants finish their recreational activity and return to the CHEERS tent, study personnel will administer Field Survey B (Appendix 6). This will take approximately 8-10 minutes.
- b. Subjects will be reminded that in the three weeks following the field interviews, they may be asked to provide a stool sample. They will be told that if they are asked to provide a stool sample, they will receive all necessary materials by FedEx delivery.
- c. Participants who swam, jet-skied, went tubing or intentionally fell into the water as part of their recreational activity will be disqualified from participating in the follow-up phone surveys. However, participants who accidentally fell into water will still be allowed to complete Survey B and the phone follow-ups.

#### 2.5.10 Incentives

After completing Field Survey B participants will be given a T-shirt that displays the CHEERS study logo and a \$15 Target gift card. They will be reminded that they will receive a check for \$35 after they complete all three follow-up telephone surveys. They will be told that if they are selected for a home visit or provide a stool sample they will receive an additional \$75.

#### 2.5.11 Special Events

As noted in the Overview document, participants will be recruited using one of three general approaches: intercept interviews, planning recruiting of teams and clubs, and special events. In 2007 recruiting participants in two special events was arranged: the Chicago Shoreline Marathon and the Chicago River Flatwater Classic. In 2008, Friends of the Chicago River will again hold the Chicago River Flatwater Classic. Canoeists and kayakers will begin on the North Branch of the Chicago River, and paddle downstream approximately 7.5 miles. This will be an opportunity to enroll as many as several hundred research participants.

At the Flatwater Classic and other large events, approximately 30 CHEERS personnel will staff the event to maximize participant enrollment. In addition to the larger number of staff performing the various functions listed above, two individuals will be “team captains” who will help ensure the smooth flow of participants through the enrollment and evaluation process. Additionally extra supply management staff will ensure that all necessary supplies are readily available to field staff. For events such as the Flatwater Classic and the Des Plaines River Canoe Marathon, which have separate put-in and take-out locations, the bulk of the research team will relocate from the site of initial recruiting/Survey A (put-in location) to the site where Survey B will be administered (take-out location).



## 2.6 Telephone interview protocol

### 2.6.1 Location and facilities

The SRL call center will be used for the CHEERS follow-up telephone surveys. All call center telephone follow-up instruments will be programmed in the SRL Blaise software for CATI (Computer-Assisted-Telephone-Interviewing) administration. The call center computers will be networked and have access to the call management software in order to track and complete the telephone follow-ups in a timely manner. Staffing of the call center at a given time will depend on the number of participants in the sample list. The call center staff will be supervised by the SRL call center supervisor, and the SPM.

### 2.6.2 Methods

Once the field data is received by SRL they will send an email confirming the number of cases they received that day. SRL will then set up a file including a list of individuals to follow-up, their case IDs, and their telephone numbers in the call management system at the call center. This turnaround of data will require roughly 24 hours (or one SRL day). Using the sample list the call center staff will contact participants by telephone on days 2, 5, and 21 following recreation. Participants who could not be reached as scheduled will be called later that day and again over the following days. Participants will also be given a contact phone number to call back if necessary. On establishing phone contact with the participant the Follow-up Telephone Interview (Appendix 7) will be administered. This interview addresses the development of symptoms of AGI and NGI during the interval since the date of recreation, or last phone contact. Other questions address water recreation subsequent to the date of enrollment, and non-water related risk factors for illness. The telephone interview process may take about 10–minutes depending on the participant symptoms.

### 2.6.3 Triggers for the collection of clinical specimens

At the end of the telephone interview a list of all study participants, who on telephone follow-up interview indicate that they have had, in the last 24 hours, symptoms of AGI, conjunctivitis or skin infections, will be generated. The criteria for clinical specimen collection will be:

- a. Any one or more of the following gastrointestinal symptoms:
  - o Diarrhea
  - o Vomiting
  - o Abdominal pain or cramps ( that for adult female participants is reported as being different than menstrual cramps)
  - o Nausea accompanied by Fever
- b. The following eye symptoms
  - o Eye drainage or crusting
- c. Skin symptoms
  - o Any draining area on the skin
- d. Acute respiratory symptoms will not prompt a home visit, given the limited value that such a visit would have in either identifying pathogens or establishing objectively the presence of infection.
- e. At the completion of the third and final telephone interview, participants will be thanked and notified that they will receive a check for \$35 in the mail.

The protocol for specimen collection is described in QAPP # 3.

### **3. Sample Handling and Custody**

Described in sections B 2 (sampling methods), and section B 9 (data management) of this document.

### **4. Analytical Methods**

#### **4.1. Health end-points, predictors, and confounders/effect modifiers for overall study**

Health end-points of interest in this study are based on previous research studies of water-related GI and Non-GI illnesses. A review of literature is presented in the Study Overview. Therefore, results of our study can be compared to other studies that have used similar end-points or definitions for GI illness (Wade, 2006; Cabelli, 1982) and non-GI illnesses (Colford 2007). The data analysis methods for the CHEERS study have been outlined in the Biostatistics section. This includes the data collected from QAPP # 1 AND # 3.

Responses to questions from the CHEERS study questionnaires (QAPP #2) will be categorized as described in Appendix 19.

#### **4.2. Interim data analysis**

Apart from the overall data analysis, the study director, biostatistician and SPM will also create interim reports of process measures (recruitment by site, attrition through the phases of the study) that will be used to modify the recruitment strategy, staffing and training involved in the study.

#### 4.2.1. Activities

Following the 2007 season we will review the kind of recreators (by activity) that we have been able to recruit in the GUW and CAWS groups of participants. For example, if we have recruited more fishers along the CAWS, compared to the GUW group, we will increase the frequency with which recruiting teams are stationed at locations where GUW fishing occurs.

#### 4.2.2. Demographics

All through the 2008 season we will also review the demographic similarities between the exposed and unexposed groups, and by activity. We want all three recreator groups to be as similar as possible in age and race/ethnicity. The 2007 data will assist in modifying the recruitment strategy for the 2008 season to ensure equal demographic representation. For example, if a large number of rowers are high school and college aged, we will seek to work with high school and college sports teams that engage in non-water recreational activities.

In addition, enrollment and attrition rates will also be followed to make necessary modifications to the study recruitment or data collection protocol.

#### 4.2.3. Interviewer bias

All forms will include the name of the interviewer. We will identify interviewers that have above average rates of incomplete “refused” or “don’t know” responses, as well as very brief or prolonged average duration of interviews. Retraining of an interviewer maybe required, based on the results.

#### 4.2.4. Health end-points

We will also analyze the data to see if there is a discrepancy between reports of symptoms and findings in clinical examination and culture. We do expect a number of participants to have negative stool cultures in spite of having symptoms.

## **5. Quality control**

Quality assurance methods have been employed throughout the questionnaire design, development, programming and administration. These have been outlined in section 2. The main goal of the questionnaire implementation process is to ensure that all data collected in the field follows a systematic process, and all data is securely and accurately transferred to SRL. This involves smooth operating of the equipment and tracking of participant progress through each station, so that at the end of the day the data for each participant is complete and all this is correctly transferred to SRL. This will lead to the compilation of a complete and usable dataset of the study analysis. The following section describes the appropriate quality control methods that will be employed before, during and after a field event.

Prior to each field event all equipment and supplies will be checked by the SPM, A-SPM, Project Supply Manager and/or the field supervisor. Any monitoring will be more heavily concentrated during the early phases of data collection and for newly-hired interviewers so that any problems in performance can be detected immediately. The monitor (who could be the field supervisor, SPM, quality manager, study director, or other designated CHEERS staff) will be instructed regarding whom and when to monitor based on random selection of interviewing stations and times during each field shift, or as a result of problems noted from previous monitoring sessions.

The ongoing monitoring of field and CATI interview permits interviewer skills to be evaluated in a number of key areas, including the ability to follow instructions correctly and the ability to probe for clear and complete answers. Through monitoring, additional factors, including the interviewer's skills in eliciting cooperation and maintaining neutrality, are routinely evaluated. Errors detected during these reviews will be recorded by the SPM to help give feedback to interviewers and to identify the need to retrain as necessary. Positive as well as negative feedback is given to ensure that the interviewers maintain a high level of commitment to quality.

The quality control checks will include (but not be limited to):

- a. Check field event supplies (outlined in Section B7)
- b. Check all study equipment- tablets, flash drives, bar-code scanners, printers etc. (outlined in Section B 6)
- c. Availability of paper-based forms (this includes the eligibility screeners, and consent forms). Any paper-based materials with participant names or Case IDs will be stored in a locking file cabinet. Only the SPM, field supervisor and data manager will have access to this box/folder. All consent forms will be counted periodically to make sure the numbers tally with the log book.
- d. Once the consent form is complete and a Case ID has been assigned (that is a bar-coded wrist band is placed on the participant's wrist) a second wrist band with the participants ID number is stapled to their consent form. This creates a paper-based record of the CaseIDs assigned to each participant. The consent forms will be stored in a secure folder on site.
- e. The data manager will record details of each Case ID and the surveys completed in field data log book.
- f. In order to assess interviewer performance, a "mock subject" will be assigned to an event during different times of the data collection process. The location, date and time will be selected randomly by the quality manager/study director. This "mock subject" will behave and participate, throughout the field event, just like any other participant, and neither field nor telephone survey staff will be aware that this individual represents a "performance evaluation" interview. The "mock subject" would have already been told to answer certain questions in a certain way. The data collected for this "mock subject" will be reviewed after the event to check if the interviewer recorded the responses correctly i.e., if the responses were coded correctly. Based on this review, the SPM will sit down with the "mock subject" and the interviewer to discuss any issues with the survey administration.

- g. At the end of each field data collection day all the tablets and files will be checked and secured by the field supervisor. The data manager will also ensure that all computer data files are consolidated and downloaded onto a flash drive following each day of field data collection. The flash drive will be transferred to the supervisor at the end of the day. The field supervisor will collect all the flash drives from the data managers at the end of each day. The data from these flash drives will be secured in a password protected zipped file and emailed to the SRL staff. In addition, an email including the details of number of participants recruited for the day will be sent to SRL.
- h. The downloaded raw data from the field will be stored in a password protected files at UIC as a back-up to the data transferred at SRL.
- i. We will track all data transmissions to and from SRL with an email. SRL staff will send an email acknowledging the number of files they received. Any discrepancies in the number of files uploaded or downloaded will be resolved immediately.
- j. A field report (Appendix 13) will be completed (See Section C) after each field data collection event.
- k. Upon receiving the files at the end of each field event SRL will create a sample list of all participant Case IDs, name and telephone numbers by date of telephone follow-up. SRL will upload the sample list to programmed call management software that will be used to track the progress of the telephone follow-up. Telephone interviewers at the call center will have access to the sample list, and can pick a Case ID to call. Once this Case ID is picked by one caller it is removed from the list until it is complete. After completion of the telephone interview, the interviewer will answer a set of pre-programmed questions that will track disconnected numbers, appointments, unreachable participants etc. After completion of the call the Case ID gets released to the call management document, that will update the status and display the status of the call, including the date and time for the next call. This assists in tracking the telephone follow-up which is critical for this study. Disposition codes will be created by SRL for use with the call management document.

The SPM will receive the call management reports at various points during the telephone interview process to track the progress of the telephone follow-ups.

- l. To receive effective feedback on the performance of telephone interviewers, it is standard SRL practice to monitor approximately ten percent of each telephone interviewer's work. Interviewers will not know when they are being monitored, since telephone monitoring is done using specially equipped extension telephones. Monitoring will be done by Interviewer Supervisors or the SPM. In addition we may use "mock participants" like we did in the field.
- m. Data integrity/ Field devices: data collected on notebooks are password protected. In addition we will use full disk encryption software to further secure all data and programs stored on the notebooks' hard disk.
- n. SRL network: The network servers use Microsoft Windows 2000, Windows 2003, and Novell IntraNetWare operating systems. These servers provide data storage, dialup data transfer, e-mail, Web services, and data backups. The Backup EXEC from Veritas is used to perform nightly backups on all network servers on the network.
- o. Weekly quality meetings will review any issues with data collection/transfer. Each week a different quality assurance procedure will be reviewed with the interviewer-recruiters.



## **6. Instrument/Equipment Testing, Inspection, and Maintenance**

SRL will develop a BLAISE CHEERS study technical manual that will address how to run/troubleshoot the field and telephone interviewing programs, how to evaluate tablet performance and conduct maintenance (including battery and key board checks), and perform bar code scanner maintenance. This manual will be made available to all CHEERS survey staff at the initial training (Appendix 1).

- Prior to a field event the Project Supply Manager and/or the assistants will check each laptop to make sure they are powered up and have 2 additional battery packs ready for use in the field. Check the tablet key boards and screens as well.
- External battery charging stations will be used to charge additional batteries.
- It will be ensured that the bar-code printer and scanners are working and the bar-coded wrist bands are prepared for the event.
- At the end of each field event (after the data is downloaded at UIC), the Project Supply Manager and/or the assistants will securely store all the tablets, printers and scanners in a locked room at UIC.

## **7. Instrument/Equipment Calibration and Frequency**

Not Applicable

## **8. Inspection/Acceptance of Supplies and Consumables**

The SPM, Project Supply Manager and/ or the assistants are responsible for making sure that all supplies outlined in the following sections are available during any field event and the telephone interviews. A supply checklist will be used to record this information before and after each event.

## 8.1 Supplies for use survey

Supplies for the use survey field study will be prepared at least one day prior to the planned activity, and stored in plastic crates in the CHEERS storage space at the UIC SPH.

Supplies to be brought to the field are:

- Clipboards
- Sunblock
- Pens
- Watches or equivalent
- Folders
- Stapler
- Identification Badges
- Use survey forms
- Cell phone
- CHEERS telephone contact directory
- Cooler with beverages
- First Aid Kits

## 8.2 Supplies for day of event

Supplies for the day of event field study will be prepared at least one day prior to the planned activity, and stored in plastic crates in the CHEERS storage space at the UIC SPH.

Supplies to be brought to the field, in addition to those listed as part of the water sampling protocol are included (Described in QAPP# 1).

- Tent
- Banners
- Folding tables
- Chairs
- Laptop computers
- Bar code scanners

- Spare laptop batteries
- Publicity flyers (250)
- Consent Document-adult (100)
- Consent Document-parental, for child (100)
- Consent Document-assent for child (100)
- Field data log book
- Bar-coded wrist bands with Case IDs
- Bar-code scanner with USB ports
- Clipboards
- Pens
- Markers
- Accordion files for signed consent documents
- USB flash memory drives
- CHEERS telephone contact directory
- T-shirts (50 XL, 50 L, 50M, 50 S, 20 kids-L, 20 kids-S, 20 kids junior)
- Target Gift cards
- Exit packets: contact information
- Cooler and beverages for study staff

## **9. Non-direct Measurement**

Not Applicable

## **10. Data Management**

### 10.1. Transfer of field data

#### 10.1.1. Electronic data copies

In the field, data obtained from Field Surveys A and B will be copied from each laptop onto a flash memory device, which will be used by the field data coordinator.

#### 10.1.2. Data file transmission

These data files will be transmitted to UIC Survey Research Laboratory (SRL) via email using password protected zip files. Once the files are transmitted, we will send the SRL staff an email with the number of cases that we transmitted, including the data transmittal form.

### 10.2. Survey Research Laboratory data handling

SRL personnel will follow this process in reverse to send to the SPM an email confirming the number of files they received. SRL will create a list of individuals to contact, their case IDs, and their telephone numbers for the call center. This turnaround of data will require roughly 24 hours (or one SRL day). For data that is transmitted over the weekend, SRL call center supervisors will run the necessary programs to create the phone list. These sample files will be loaded onto a desktop with the call management software, to use as our telephone follow-up sample list. SRL will create a field report after each event. This will be reviewed by the SPM or A-SPM to track recruitment/attrition rates on a weekly basis.

### 10.3. Transfer of telephone data

At the end of each day all telephone interview forms will be saved on the desktop and uploaded to the SRL server. SRL will create reports through the call management system. These reports will be monitored on a weekly basis by the SPM, or the A-SPM.

### 10.4. Paper forms

Consent documents, any paper based forms and Case ID logs will be placed into locked boxes/ folders on site. The originals will be stored in a locked file cabinet in an assigned CHEERS office.

### 10.5. CHEERS study datasets

The SRL Office of Survey Systems (OSS) will be responsible for creating the final datasets for the CHEERS study. Because all responses are entered directly into the computer at the point of interview, the time consuming and potentially error prone process of converting raw data responses to machine readable form is largely eliminated. To create an output file ready for analysis, the data processing component creates a blank rectangular file and fills in codes from closed-ended questions (and open-ended questions that have been coded), using the skip logic programmed into the survey questionnaire. This process can be executed concurrently with data collection (and is done at regular intervals as another quality control point).

The processing component is also used to test and edit the data while producing clean computer files. When clean files are available, the system also produces documentation. This includes code books, record layouts, and SAS, SPSS or STATA control cards (with both variable and value labels). These code books can be used to produce absolute and percentage frequencies and/or cross-tabulations for every coded variable at any time during the study and routinely used as part of the quality control procedures.

SRL will deliver one preliminary and one final dataset at the end of each season for each time-point/instrument prepared in SAS. These deliveries will contain lists of open-ended responses, too. The SPM will be responsible for all coding and back coding of data at that point. A final methodological report that summarizes the study design, questionnaire development process, and programming and data processing procedures will be submitted by SRL.

All datasets will be saved in password-protected computer files. The datasets will not contain any participant names or contact information. Access to the datasets will be restricted to the study director, SPM, biostatistician and other personnel involved in the data analysis and report writing process.

## **C. ASSESSMENTS AND OVERSIGHT**

### **1. Assessments and Response Actions**

- a. IRB certification tracking: CHEERS staff will not be allowed to participate in any field work involving human subjects without current IRB certification.
- b. All CHEERS staff must complete the CHEERS survey training on interviewing techniques that will be conducted by the SPM. This training will also include the mock interview. Only after the SPM has observed and signed off on the mock interview and training process and verified the IRB certification status, will a CHEERS staff member be allowed to recruit participants in the field.
- c. The SPM, A-SPM, or field supervisor will be in charge of observing the process in the field on any given day. The field report completed at the end of each field event will include any information on unusual occurrences, staffing problems, staff concerns, and equipment issues. In the event of any trouble that cannot be resolved in the field, it is the responsibility of the SPM to submit the field report to the Study Director and the Quality Manager, who will have the final authority to make any decisions regarding staffing, equipment changes or other participant issues.

- d. The SRL call management document will track the telephone follow-up process (See Section B5).
- e. Any field and telephone interviewing issues specific to an interviewer in the field or during the telephone interview process will be identified using “mock subjects” and CATI interview screening methods. Steps will be taken to assist/retrain the interviewer, or the interviewer may be reassigned to other appropriate tasks (See Section B5).
- f. Any equipment that does not work will be fixed before the next field event. For example, if we have trouble with a tablet key, the SRL- CHEERS study technical manual will be used to resolve the issue, failing which, SRL will be contacted to service the tablet before taking it to the field. All equipment failure will also be reported to the Study Director and Quality Manager (see Section B6).

## **2. Reports to management**

All CHEERS questionnaire related documents described in the preceding sections (See List in Section A9) will be stored by the SPM. It is the responsibility of the SPM to make these available to the CHEERS Quality Manager and study director at all times. Any unusual occurrence reports will be submitted within 24 hours to the quality manager. Any recruitment issues, staff related issues or equipment trouble will be reported within 24 hours to the Study Director.

In addition the interim data analysis reports (as described in Section 4) will be submitted to the study director as outlined in Project Quality Management Plan document, or as and when requested.

## **D. DATA VALIDATION AND USABILITY**

Data review, verification, and validation methods have been employed during the development, programming and implementation of the survey methods. These are outlined in Section B and include:

- Questionnaire review and validation process (including internal/external reviews, IRB clearance, and pilot evaluations of survey questions)
- Use of CAI (Computer Assisted Interviewing Techniques) and limited open-ended questions to ensure accurate data entry. The questionnaires have been developed with pre-determined acceptable response options. This prevents the entry of unacceptable or out of range responses.
- Data will be deemed unusable if the transmission of data files introduces errors in the dataset. There are control in place to prevent this (back up data files on desktops, transmission reports etc), and an error could be identified by a mismatch in the encrypted emails (generated at the time of uploading data to SRL) and the number/type of files received by SRL. Any mismatch will prompt a review of the status of that particular Case ID awaiting upload, and/or the Case ID's forms received by SRL.



## References

- Cabelli VJ, Dufour AP, McCabe LJ, Levin MA. 1982. Swimming-associated gastroenteritis and water quality. *American journal of epidemiology* 115(4): 606-616.
- Wade TJ, Calderon RL, Sams E, Beach M, Brenner KP, Williams AH, et al. 2006. Rapidly measured indicators of recreational water quality are predictive of swimming-associated gastrointestinal illness. *Environmental health perspectives* 114(1): 24-28.
- Colford JM, Jr., Wade TJ, Schiff KC, Wright CC, Griffith JF, Sandhu SK, et al. 2007. Water quality indicators and the risk of illness at beaches with nonpoint sources of fecal contamination. *Epidemiology* 18(1): 27-35.

## **QAPP 2**

### **Appendix 1: CHEERS Survey Training Manual**

# **QAPP 2**

## **Appendix 1A**

### **CHEERS Survey Training Manual**

#### **Gaining Cooperation**

## **GAINING COOPERATION**

Let's start out by talking about the role of the interviewer. This part of the discussion will be brief because we will talk about each of the points in more detail later. The following discussion will highlight the role of the interviewer.

### **1. It is important for interviewers to gain cooperation from recreators.**

The percentage of people who answer our questions is critical. A high response rate means greater confidence in the results of the study. You all know about response rates from watching the nightly news. How many times have you heard a report of the outcome of a poll that states 57% surveyed support something (+/-3%)? That means that between 54% and 60% support the issue. The (+/- 3%) is the confidence interval.

A low response rate means a greater chance of error. We need to avoid getting a low response rate.

### **2. It is critical for interviewers to communicate that we are doing scientific surveys.**

You are now all professional interviewers and researchers. The key to communicating that is to practice good techniques.

- Know the answers to the CHEERS FAQ Sheet inside and out, backwards and forwards.
- Use your voice. Don't try to sound like someone else.
- Be confident and professional.

### **3. It is important to practice your delivery.**

Throughout this training use every opportunity you get to read as a chance to improve your ability to communicate that you are a professional interviewer.

#### **4. True or False: People don't want to do surveys?**

This is a myth. People don't want to talk with a telemarketer. We do scientific research. People will answer our questions because they are posed by researchers, and it gives them a chance to be heard.

How we are different from telemarketers:

- We are not selling anything.
- We are not asking for any money.
- We will provide written information about the survey.

#### **5. It is important to be prepared to answer respondents' questions.**

Respondents are likely to ask questions before you even get started with an interview. For each survey, we anticipate these questions and provide you with answers. You each have a copy of the CHEERS FAQ Sheet, which you should always keep available for quick reference. Practice the answers to these questions. It is necessary for you to be able to answer them with correct information in a confident and natural manner.

#### **6. Turning a "No" into a "Yes!"**

Listen carefully to the respondent's question, answer briefly and to the point, and then continue with gaining their cooperation.

Your interest in the survey is communicated to the respondent by your voice, body language, and appearance. There should be a pleasant and professional tone to your voice. You should display open or neutral body language. Do not stand too close to the respondent.

You need to listen to the respondent's tone and watch his/her face and body language. At what point did s/he become hesitant or uncomfortable? Is it possible s/he misunderstood something you said? You must be prepared at all times to answer his/her questions and you need to speak to him/her at his/her level of comprehension, without sounding condescending.

Most respondents do not refuse outright; rather they express some hesitancy, reservation or initial hostility. You will soon become sensitive to the firmness of the "no" conveyed by the respondent's tone of voice and the wording of his/her comments. You will also learn to sense the reasons behind a respondent's hesitancy and develop ways of dealing with those "hidden" concerns. Listen very carefully to what the respondent has to say, and then address your remarks to the respondent's concerns.

## **7. Common Reasons Given for Refusing**

The reasons why respondents refuse are varied, and the approaches for handling them will vary from respondent to respondent and Interviewer to Interviewer. There will be times when a refusal cannot be avoided.

Listed below are some common reasons respondents give for refusing:

- Too busy; don't have the time;
- Not interested in the survey;
- If I participate, you'll ask me to do more interviews later.
- Don't want to be bothered/ don't want to be involved.
- Afraid of being involved;
- Waste of time and money;
- Government interference;
- "Nothing in it for me."
- Too ill; don't feel well enough;
- I don't give out that type of information, and
- How do I know who you are/this survey is legitimate?

These reasons reflect the broad types of concerns respondents may have about the time you are asking him/her to give and/or about surveys in general, as well as specific concerns

about the survey itself. When a respondent refuses, it is important that you listen carefully and if possible, clarify the reason for the refusal.

Your responses should emphasize the importance of the survey and assure the respondents that we appreciate their contribution to the project.

**REMEMBER: Remind them that their participation is really important to the Cheers Study and all information they provide to us will be kept confidential.**

### **Factors Affecting Respondents' Participation**

There are factors, both positive and negative, that may affect a respondent's decision to participate in any survey. Let's look at some of the negative factors involved and how they can be used to gain completed interviews.

- Fear of the survey, the interviewer or the use of the data;
- Hostility toward the interviewer or the sponsor;
- Perceived invasion of privacy;
- Assumed threatening subject matter; and
- Cost to them in terms of time and energy.

A knowledgeable interviewer who is LISTENING to the respondent and answering the respondent's objections directly can counter all of these factors.

The following are some of the problems you may encounter as you start doing interviews. Let's look at the negative factor involved in each problem and talk about the ways to avoid or lessen the problem.

**1. Respondent is suspicious or expresses doubt about the legitimacy of the survey and your role.**

This factor is sometimes expressed by the respondent by asking, "What are you selling?" "Why did you pick me?" "What are you going to do with the data?" or "If I participate, you'll keep coming back to me for more information."

To counter the concern, you can:

- Let your respondent know you are not selling anything.
- Show him/her your badge.
- Restate confidentiality.
- Restate the purpose of the survey.
- Let the respondent know the information will only be released in statistical form--that we will take everyone's' results and average them together, and that no one outside of the survey will be able to put his/her responses with his/her name.
- Tell him/her that his/her name will be separated from his/her data before it is analyzed and his/her data can be traced back to him/her; or
- Offer to let him/her speak to your Field Manager/Data Manager/Supervisor.



**2. Respondent refuses outright without listening to any information about the project or without listening to your entire introduction.**

You may hear, "I'm not interested," or "I can't be bothered." You can:

- In response to "I'm not interested" or "I can't be bothered," your first response should always be, "May I ask why not?" You want to be very careful how you say this and to not sound rude, abrupt, or unsure of yourself. If the question is asked sincerely and there is a look of concern on your face, the respondent should not object to you asking. This question can open up a dialogue with the respondent, so that you will be able to provide him with more information and help him become more comfortable with the survey. In addition, this is something you can record on your tracking log.
- Be sure to ask him/her if there is any more information you can give him/her, and restate that you are not selling anything.

**3. Respondent expresses concern about the survey or the use of the data.**

You may hear, "I don't give out personal information" or "I don't want to give out my information because of what you may do with it." You can:

- Let your respondent know what will happen to the information/data s/he gives us;
- Reassure him/her of the confidentiality of the data;
- Restate the purpose of the survey;
- Let him/her know s/he can refuse to answer any question that makes him/her uncomfortable; or
- Offer to let him speak to your Field Manager/Data Manager/Supervisor.

**4. Respondent is concerned about costs in terms of time and energy.**

You may hear, "I'm too busy," or "Are you going to pay me for my time?" or maybe you will hear, "What's in it for me?"

- You need to let the respondent know that each questionnaire will take about 15 minutes. Also inform them that they will receive a \$15 gift card and a t-shirt in the field, followed by a \$35 check in the mail after the 3 telephone interviews.
- Restate the purpose of the survey.

**5. Respondent expresses distrust of government studies.**

This may be expressed as "The government never listens," "This is a waste of taxpayer's money," or "The decisions have already been made."

- These objections often just need to be heard--then the respondent is willing to cooperate. You should just listen and accept his/her feelings in a neutral manner.
- Assure him/her that his/her views and experiences are important.
- Tell him/her that we don't want his/her experiences to be overlooked.
- Restate the purpose of the survey. Also tell them- we are the UIC School of Public Health and this is a scientific study.

**6. Other Questions and Concerns Respondents May Have About the Survey**

- **How was I selected for the survey?** Explain that anyone who recreates in or around these waterways is eligible to complete the survey.
- **How will the results be used?** The results of this survey will be used to help us learn more about water quality and health of people who recreate in these waterways.

**Other Ways to Avoid Refusals**

**1. Listen carefully to what the respondent is saying.**

- What is the reason for his objection? If it is not clear to you, ask the respondent to explain further. Probe as necessary but not to the point of annoyance. Then you should respond to his/her stated reason (s).

**2. Acknowledge that you have heard and understood the respondent's objections.**

- Be sympathetic, using phrases like, "I understand how you might feel that way," or "That's very interesting." These phrases express in a neutral way that you have heard the respondent's objections. You want to avoid too brief an acknowledgement like "Yes, but..." that may be seen by the respondent as a dismissal of his feelings.
- Be direct, answer only what is asked and get right back to the business at hand--getting the respondent to complete the questionnaire. You can tell the respondent s/he can start the questionnaire and see how it goes, and that s/he can skip any questions s/he does not want to answer.
- Do not volunteer additional information--which will only lead to more questions on the respondent's part.
- If you do not know the answer to a question, be honest and tell the respondent that you do not know, but will find out. Then see your Field Manager/Data Manager/Supervisor on site and get the answer for the respondent. This shows the respondent that your actions match your words and will help convince him/her that the other information you are giving him/her (the survey sponsor, use of the data, confidentiality, etc.) is true.

### **Tips for Gaining Participant Cooperation**

- Carefully prepare for your interviewing day. A knowledgeable and enthusiastic interviewer is the best defense against a refusal. Review your manual as often as necessary, so you can answer respondents' questions without hesitation.
- Be thoroughly familiar with all the survey materials so you can readily answer a respondent's questions about the survey.
- Make sure the respondent knows exactly who you are and why you are asking him/her to be in the survey.
- Make sure your respondent feels s/he is valuable to the survey and knows how important his/her participation is.
- Approach the respondent confidently and calmly. If you are not confident in what you are doing, the respondent will quickly pick up on your nervousness. Listen very carefully to the respondent's voice and watch his/her face and body language. Knowing how to put the respondent at ease is one of the most important refusal avoidance tools you can utilize in your efforts to gain cooperation. Regardless of your respondent's mood or attitude, you must always remain calm, confident, and pleasant.

- Try to establish a good rapport as quickly as you possibly can. Getting the respondent to start (and finish) the survey is the purpose of your efforts as an Interviewer. Avoid unnecessary conversation with respondents.
- Never take a refusal personally. No matter how good an interviewer you are, you are going to get refusals.

### **Results of Your Efforts**

**1. What will happen when you are successful in answering respondents' questions?**

Your respondent will cooperate and the respondent will complete the survey.

**2. What happens if you are not successful at convincing them to continue with the survey?**

It is important that you know when to stop. If you feel your respondent is becoming annoyed instead of just hesitant you should discontinue your efforts.

If you get a couple of refusals, and it is starting to get you down, speak with your Field Manager/Data Manager/Supervisor. They can help get you “back on track.”

# **QAPP 2**

## **Appendix 1B**

### **CHEERS Survey Training Manual**

#### **Probing**

## Section 11. Probing

---

**When you finish this section, you should:**

- ✓ Know how to probe initial 'don't knows' and refusals
- ✓ Know how to probe for amounts, dates, and numbers
- ✓ Understand how to probe on precoded and open-ended questions and the difference between them
- ✓ Know the correct way to record probes on open-ended questions
- ✓ Know what it means to probe to the point of the question
- ✓ Understand how to probe for additional ideas
- ✓ Be able to successfully probe for occupation

Ideally, respondents would answer most or all questions using the response categories provided. In reality, that doesn't always happen. **Probing** is an interviewing technique used to obtain specific, complete and relevant answers from a respondent. It is one of the most difficult skills used in interviewing, but can also be one of the most rewarding.

An interviewer who probes well is natural and friendly and shows a real interest in the respondent while maintaining his or her neutrality regarding the respondent's answers. Without being overly aggressive or seeming to cross-examine the respondent, the interviewer works *with* the respondent to obtain specific information for the researcher. Remember that the purpose of many studies is to help researchers make decisions about programs or services for the public. This cannot be done unless specific likes, dislikes, problems or experiences are known. You act as a "reporter" for the people you interview, trying to get all the details possible for the story.

### 11.1 Probing Initial "Don't Knows" and Refusals

When a respondent answers "I don't know" to a question, it may mean one of several things:

1. He is in a hurry to get the interview over with and doesn't want to take the time to think about an answer;
2. The subject of the question is something the respondent has never thought about before;
3. The respondent does not feel he is expert or knowledgeable enough to give the "correct" answer; or
4. The respondent really has no idea of the answer.

In the first two situations, a remark such as, "I wonder if you could take a moment to think about it" is appropriate. In the third situation, reassure the respondent that there are no right or wrong answers and that we are only interested in his opinions. In the fourth situation, encourage the respondent to give his impressions or, if the question asks for a number, help him or her arrive at an estimate.

When a respondent refuses to answer a particular question, remind him of the confidentiality of the information and opinions he gives.

Probe initial "don't know" responses and refusals *once* in an effort to obtain an answer. Do not, however, badger the respondent to answer or convey the impression that you are annoyed by his inability or refusal to answer.

## **11.2 Probing for Amounts, Dates and Numbers**

When a question requires a numerical answer, the respondent may answer with a range rather than a single number, or in units different than those asked for, or he may

initially say, "I don't know." In each of these situations, it is necessary to probe for the specific information required in the question.

**If the question asks for a dollar amount and**

1. the answer is given as a range, probe with "I need (or would like to record) an exact figure if possible." This tells the respondent that you are interested in exact amounts. The same probe should be used for responses such as "Oh, around \$200."
2. the respondent says, "I don't know," probe with "Just your best estimate is fine."

**If the question asks for a date and**

1. the respondent answers with a time reference, such as "a year or so ago," probe by asking the calendar information that you need: "What was the actual date?" or "What month and year would that be?"
2. the respondent gives only part of the information you need to record, for instance, only the month or only the year. Again, probe by asking for the missing piece(s) of information.
3. the respondent says "I don't know," begin by asking the respondent to try to remember the time of year or the season. If he can't remember, ask him to think about anything else that may have been happening at that time which would help him pinpoint the date more exactly.

**If the question asks for a number and**

1. the respondent gives a range such as "two or three," probe with "I need to record a single number; which would you say is correct?" or "Which would you say would be most likely; 2 or 3?"
2. the respondent answers in units that are different from those required by the question (hours instead of minutes, weeks instead of months), probe by asking for the answer in the units needed: "How many months would that be?" The same method should be used if he replies with a time reference instead of a number: "Once a week," when you have asked for the number of times per month.
3. the respondent says, "It depends," probe with "On the average" or "Usually . . ."



4. the respondent says, "I don't know," probe with "Just your best estimate."

### 11.3 Probing on Precoded Questions

Remember that precoded questions are used when researchers want the respondent to place himself or his opinions in one of several predetermined categories.

Let's look at our examples of precoded questions again:

Would you say your health is excellent, very good, good, fair or poor?

- <1> Excellent
- <2> Very good
- <3> Good
- <4> Fair
- <5> Poor
- <8> DON'T KNOW

Are you now . . .

- <1> Married,
- <2> Widowed,
- <3> Divorced,
- <4> Separated, or
- <5> Have you never been married?
- <9> REFUSED

In precoded questions, probing is used to focus the respondent's attention on the question and/or to direct the respondent's attention to the existing code categories. You must indicate to the respondent that his job is to choose one of the existing code categories *without* biasing his response or leading him to a particular category. You should repeat all categories to the respondent without narrowing down his choices for him. Always preface a repetition of the code categories with an appropriate acknowledging remark. If the respondent answers in his own words instead of using an

answer category, a prefacing remark such as, "Well then, would you say . . . ?" or "Would that be . . . ?" is appropriate. If the respondent says, "It depends," a remark such as, "In general, would you say . . . " or "Overall, . . . " will let him know that we want him to generalize on the subject.

If, after probing, the respondent does not choose an existing category, record his answer verbatim and go on to the next question. On PAPI questionnaires, record verbatims that do not fit into existing code categories in the left-hand margin. On CAPI studies, record this type of verbatim using the NOTE command before entering the code for "No coded response applicable."

#### **11.4 Probing on Open-Ended Questions**

On open-ended questions there are no precoded answer categories. The respondent is allowed to answer in a free-flowing manner, in his own words. The interviewer records the responses(s) as the respondent speaks, in his own words. Let's look at our examples of open-ended questions again:

Why did you choose to live in this location?

---

---

---

What do you like about your HMO?

---

---

---

Because open-ended questions tend to be very general, respondents tend to answer in a general way and to use general adjectives when describing situations and opinions. Respondents also tend to give brief or single answers without going into much detail. For this reason, two types of probing are used in conjunction with open-ended questions--**probing for clarification**, which is always used, and **probing for additional ideas**, used when you are instructed to do so in the questionnaire.

## 11.5 Probing for Clarification

**Probing for clarification** is often a matter of asking for specifics or an explanation. Never assume that a respondent is using a vague or general word or phrase in the same way you would. The same general word can mean many different things to different people.

There are many general words or phrases used in everyday conversation that should automatically suggest to an interviewer that probing for clarification is needed.

Below is a list of some of the more common words that should always be probed.

<b>Positive</b>	<b>Negative</b>
like	dislike, don't like
good better, better off best	not good, poor, bad worse, worse off worst
(good) quality (high) quality (good) reputation (good) appearance	(poor) quality  (poor, bad) reputation (poor, bad) appearance
appealing satisfying satisfactory	unappealing dissatisfying unsatisfactory
convenient	inconvenient
effective works	not effective, ineffective doesn't work

---

**Can Be Positive or Negative**

---

different  
interesting

okay  
all right  
average

cost

cheap  
expensive

Probing for clarification should encourage the respondent to speak *without influencing his answer*. The potential for introducing bias while probing is great. Under pressure of the interview situation, an interviewer may imply quite unintentionally that some responses are more acceptable than others or that a respondent may want to consider certain things in formulating his answer. Many respondents wish to be helpful; if they can tell how you as an interviewer feel about the subject, they may answer in a way they think would please you. Be careful not to encourage the respondent with your reaction to his answers. Avoid saying, "That's good," "That's true," or "That's right." Also be careful not to suggest possible meanings or specific connotations to the respondent. Remember that you must remain impartial during every moment of the interview.

In short, the best probes for clarification are those that tell the respondent exactly what kind of information or response you want from him without leading him toward a specific possible response. Some examples of neutral probes that can be used are:

What, specifically, do you mean by (\_\_\_\_\_)?

What, exactly, was (\_\_\_\_\_)?

In what way was it (\_\_\_\_\_)?

What about the (\_\_\_\_\_) do you (like/dislike)?

Would you explain that please?

Would you describe that for me?

Tell me a little more about that.

Often a respondent will volunteer more than one general word or idea that needs to be clarified, *or* he may answer a probe with just another general word. You are expected to *probe each word or idea that needs clarifying* and to *probe each as many times as necessary* until it is clarified. If the respondent is unable to clarify or be more specific in response to your probe, move on.

# **QAPP 2**

## **Appendix 1C**

### **CHEERS Survey Training Manual**

#### **A Typical Day for the CHEERS Staff**

## A TYPICAL DAY FOR THE CHEERS RECRUITER

This is a general overview of a typical data collection day for a CHEERS recruiter/ interviewer/incentive person. Please note you can be assigned to do one or all of these jobs on any given day.

- Arrive at the pre-designated site at the given time. Please inform the on-site Data Manager or the CHEERS Field Supervisor (for that day/location) if there are any unforeseeable delays.
- Wear your CHEERS study T-shirt; and
- Wear appropriate pants and shoes.
- Report to the on-site Data Manager. He/She will record your arrival on a time sheet.
- Listen to changes/location specific details/ additional instructions and for any adjustments; and
- Ask any questions, if necessary. There will always be copies of CHEERS Study FAQ sheets and Water quality info. sheets available to help you prepare for the day.
- Please discuss your lunch time/break times before you start work
- Pick-up recruiting material and place on clip-board. This includes:
  - Location specific flyers
  - Eligibility Screener (Make sure you know what time the CHEERS study will wrap up that day)
  - We are interested in water recreators before they start their activity of the day.
  - We are interested in non-water recreators at any time before/during/after their activity.
  - Participants must be able to return to the CHEERS tent to complete Survey B before we end the CHEERS event for that day.
  - Refusal Tally sheet
- Commence recruiting. **Check Recruiting script, CHEERS FAQ Sheet, and slides for more help.**
- Return all recruiting material at the end of the day.
- De-brief with the on-site Data Manager.



- Ask questions/get clarification, if necessary
  - Discuss any problems you encountered during the day;
  - Discuss any positive elements of the day; and
  - Listen for general instructions.
- Checkout for the day. Data Manger will complete your time sheet.

### **A TYPICAL DAY FOR THE CHEERS INTERVIEWER**

- Arrive at the pre-designated site at the given time. Please inform the on-site Data Manager or the CHEERS Field Supervisor (for that day/location) if there are any unforeseeable delays.
- Wear your CHEERS study T-shirt; and
- Wear appropriate pants and shoes.
- Report to the on-site Data Manager. He/She will record your arrival on a time sheet.
- Listen to changes/location specific details/ additional instructions and for any adjustments; and
- Ask any questions, if necessary. There will always be copies of CHEERS Study FAQ sheets and Water quality info. sheets available to help you prepare for the day.
- Please discuss your lunch time/break times before you start work
- Pick-up your laptop and scanner. Commence interviewing. **See the slides for more help.** The following items are of most importance:
  - Don't Be in A Hurry: Slow down, be patient, and be observant.
  - Record the CASE ID number very carefully. Double check Case ID entries.
  - Be Accurate: Listen intensely to what the respondent is saying to you. Capture the respondent responses exactly as they give them to you.
  - Repeat: Repeat back to the respondent all names, addresses and phone numbers. This is the method that is used to accurately match the two parts of the survey.
  - Report any data/laptop troubles to the on-site Data Manager immediately.

- Check to make sure each participant has completed Survey A before they do Survey B.
- All water recreators will receive Survey A before their activity and Survey B after their activity.
- All non-water recreators will receive Survey A and B at the same time.
- If you enter the wrong case IDs or you start the wrong survey, or you lose power and restart the survey on a new laptop- PLEASE ENTER ALL THIS IN A REMARK and inform the DM.
- Check the laptop battery power every now and then. If power is 25% or less then please swap the battery and inform the on-site data manager.
- Always close all surveys before placing laptops on stand-by or powering off. We need to protect the data and save battery power in the field.
- Protect laptops from sun/rain/physical damage. They are your responsibility.
- Return all laptops and scanners at the end of the day. The on-site Data Manager will download all the data before you pack them in their bags.
- De-brief with the on-site Data Manager.
  - Ask questions/get clarification, if necessary
  - Discuss any problems you encountered during the day;
  - Discuss any positive elements of the day; and
  - Listen for general instructions.
- Checkout for the day. Data Manger will complete your time sheet.
- ***Please note: You may be asked to go out and do some mobile interviewing- if so, you will be a recruiter/mini- data manager/ interviewer. This means:***
  - ***You will approach participants and recruit them***
  - ***You will complete the consent process and assign a Case ID.***
  - ***You will do the surveys.***
  - ***You will record this data on a log and return to the tent for***

*incentives.*

- ***You will report all data to the on-site Data Manager.***

**A TYPICAL DAY FOR THE CHEERS INCENTIVE PERSON**

- Arrive at the pre-designated site at the given time. Please inform the on-site Data Manager or the CHEERS Field Supervisor (for that day/location) if there are any unforeseeable delays.
- Wear your CHEERS study T-shirt; and
- Wear appropriate pants and shoes.
- Report to the on-site Data Manager. He/She will record your arrival on a time sheet.
- Listen to changes/location specific details/ additional instructions and for any adjustments; and
- Ask any questions, if necessary. There will always be copies of CHEERS Study FAQ sheets and Water quality info. sheets available to help you prepare for the day.
- Please discuss your lunch time/break times before you start work
- Pick-up the incentive material. This includes:
  - The incentive check list on a clipboard.
  - The gift-cards/receipt book.
  - Stool flyers.
  - T-shirts
- Commence incentive distribution. **See slides for more help.** Please be aware:
  - Count all gift cards at the beginning of your shift and enter the number on the white form provided in the gift-card box.
  - Record the date/location and start/end gift card count on the incentive sheet before you start your day and at the end of the day again.
  - You will be stationed at a table close to the on-site Data Manager.

- **Please make sure all participants have completed Survey A and Survey B- before they take their incentives.**
- Take their wrist bands before they leave. Please collect as trash.
- Participants can choose to donate their cash (\$50) incentive. They will sign the consent form. The on-site Data Manager can help you track this. If someone says they are donating their cash incentive to any club/team/group then-

**DO NOT GIVE THEM A GIFT CARD.** Enter “**DONATE**” next to their case ID. This data is very important as we track donations every week.

- If you run out of t-shirt sizes you can record details of the participant NAME, ADDRESS AND T-SHIRT SIZE. We can mail it out to them. Please give details to the on-site Data Manager.
- Once again, count all gift- cards and enter the number on the white form provided in the gift-card box at the end of your shift/day. You are responsible for an accurate account of the gift cards. This is as good as cash.
- De-brief with the on-site Data Manager.
  - Ask questions/get clarification, if necessary
  - Discuss any problems you encountered during the day;
  - Discuss any positive elements of the day; and
  - Listen for general instructions.
- Checkout for the day. Data Manger will complete your time sheet.

# **QAPP 2**

## **Appendix 1D**

### **CHEERS Survey Training Manual**

#### **BLAISE Field Interviewer Training**

# **Blaise Manual for study 1027 CHEERS**

## **(7/19/07)**

### **Logging in to your laptop**

After you turn the computer on, you will be prompted for your user name and password. Select the user name “user” (not “admin”), and enter the password you were given to use during training. If you bypass the sign-in dialog by closing the window or pressing the Escape key, the programs will not work.

**Password: survey**

## Checking the time and date

After you've logged in, you will be presented with a time/date window. You should verify that both are correct, and fix them if not. (The time and date are used by the instrument in various calculations.) After you are done, press the "OK" button to continue.

Figure 2

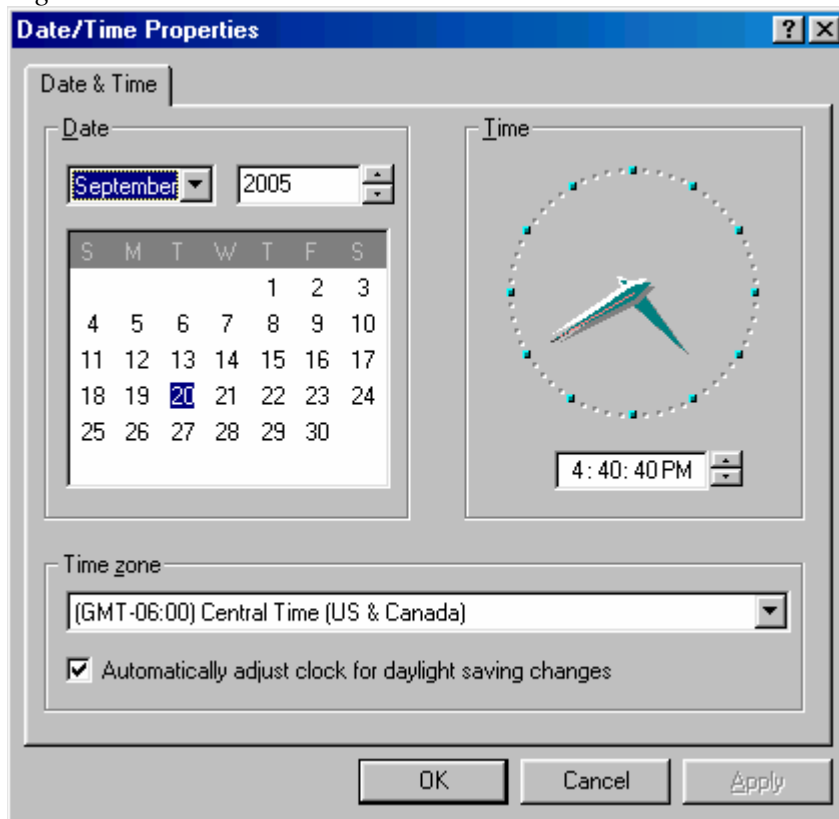

## Verifying that you are running off of a wall plug rather than the battery

It's very important that interviews be carried out while the laptop is plugged in, if at all possible. The battery is intended as backup, to prevent the loss of data in the case of a power outage; it's unlikely that you will be able to complete an entire interview on battery power alone. PLEASE CONDUCT A BATTERY CHECK- IF YOU HAVE 25% OR LESS POWER THEN YOU NEED TO SWAP THE BATTERY.

There are two kinds of laptops used for the 1057 study: IBM and ACER. The laptops have been set up so that an icon in the system tray (at the bottom of the screen, on the right) shows you whether you are operating on "full" or "battery" power, and, if you are operating on battery power, tells you what percentage battery power you are operating on. The icons for the two kinds of laptops are different.

For the laptops:

- 1) An icon that looks like a plug with a blue lightning bolt over it indicates you are running on full power. If you rest your mouse on the icon, it will give you a message like “92% remaining (charging)”, indicating that your battery is “92%” charged and that the laptop is in the process of further charging the battery. You should double-click on the icon to get a display like the following, confirming you are plugged in and giving you additional details.

*Figure 5*

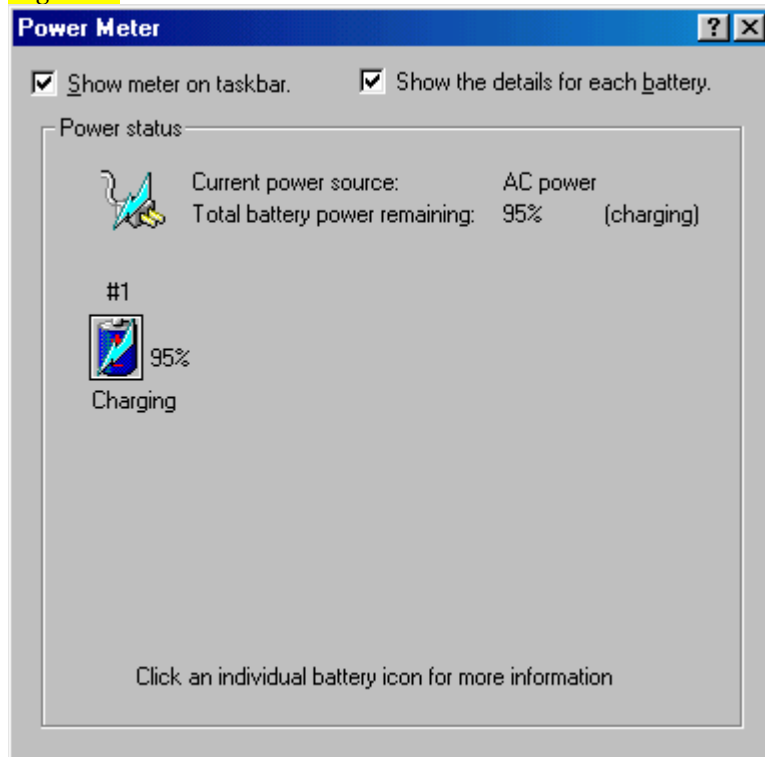



- 2) If the icon appears as a blue battery, with a red plus and minus sign on it, this indicates that you are running on battery power. If you rest your mouse on the icon, it will give you a message like “96% remaining”, indicating that your battery is “96%” charged. You should double-click on the icon to get a display like the following, confirming you are running off the battery and giving you additional details.

Figure 6

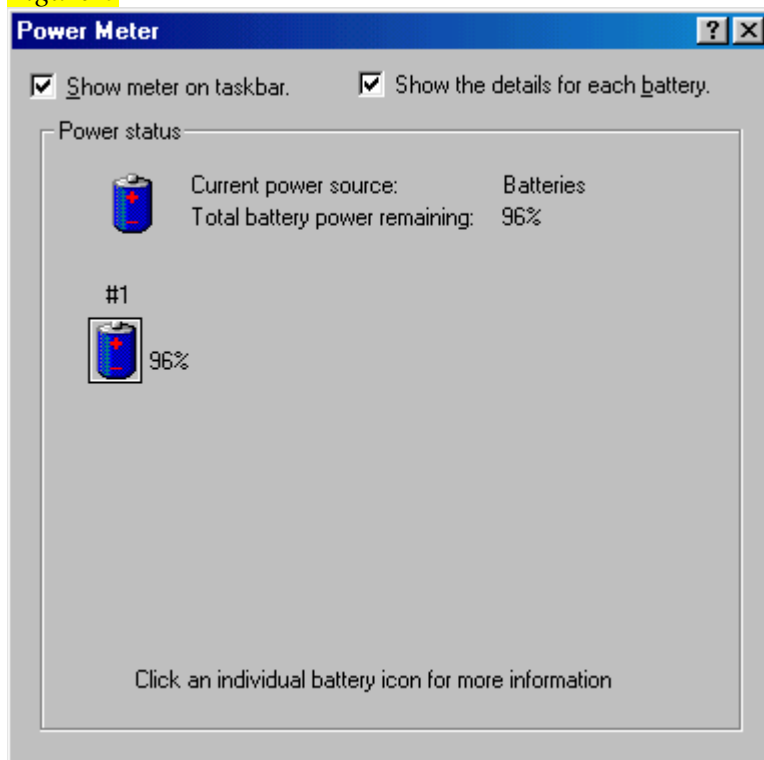

- 3) You can also tell that the laptop is running on full power from a small indicator light on the laptop itself: above the left-hand corner of the keyboard. If the laptop is plugged in to a working outlet, the light under the image of a plug will be on, otherwise not.

## **“CHEERS” desktop folder**

### **Icons for data collection**

- 1) “Run Part A”, “Run Part B” : used for data collection with actual respondents; for further instructions see the section on “Accessing the Blaise instrument for data collection”, below.
- 2) “Salvage”: used to recover if your case locks or you get other error messages indicating a problem with the database; for further instructions see the section on “Salvaging a case after data problems”, below.

### **“Training” directory (for training/review)**

- 1) “Joint” sub-directory:
  - a) “Run Training” will allow you to go through the entire questionnaire using a training case. (Do **not** use this icon for actual data collection.)
  - b) “Salvage Training” is a training version of the “Salvage” icon.
  - c) “Training Sample.xls” = copy of test sample file, which you will need in order to run through a case in the “Joint” directory; it lists the CaseID and associated Randno values which you will need to type in when prompted by the program.
- 2) “Section1” – “Section9” and “Post” sub-directories:

Each of these sub-directories has a “Run Training” icon which will allow you to practice on just that particular section of the questionnaire. (Click to start.) You will not need to enter a CaseID and Randno to go through these.

## **Accessing the Blaise instrument for data collection**

- 1) Click onto desktop folder CHEERS.
- 2) Click on the appropriate icon for the phase of the study or training you are working on.
- 3) Click on the “Main Laptop” folder.
- 4) Click on the “Part A. bat” or Part B. bat” file icon- This will bring up the study instrument in the Blaise data entry program.
- 5) To access a particular case, see instructions under the “Accessing a case (‘form’)” section below.

## **Troubleshooting**

*You click on your “Run” icon and nothing happens – Try clicking on it several times. All icons should be working but sometimes you have to click on them several times before they will kick in. (NOTE: the “Salvage” icon discussed below will run a program very quickly in the background; you may see only a flash on your screen, and you should test before clicking on “Salvage” again.)*

## **Salvaging a case after data problems**

- 1) You may need to salvage a case if it locks (freezes on a particular screen and will not let you go backwards or forwards), or if you get an error message that refers to the data or database being corrupt or unusable.
- 2) The very first thing you should do is to write down the error message (if you get an error message), and a description of what went wrong.
- 3) Then exit Blaise and attempt to re-enter the case regularly (without using “Salvage”). Only if that fails should you proceed to salvage.
- 4) To salvage start by clicking onto desktop folder ST1057 Patient and then click on the “Salvage” icon (right beside the “Run Production” icon). This will cause the salvage program to run very quickly in the back-ground (you may see just a flash on your screen).
- 5) Now attempt to re-enter the case you were in.
- 6) If you still cannot access the case, run salvage one more time and attempt to re-enter the case.
- 7) If you still cannot re-enter the case, you can call one of the SRL staff members listed in your manual, and we will attempt to address the problem over the phone with you.
- 8) If none of the above works, you will need to reschedule your appointment with the respondent and return as soon as possible to SRL so that we can take a look at your computer.

## Blaise screen layout

Each Blaise screen consists of 5 basic sections:

Figure 7

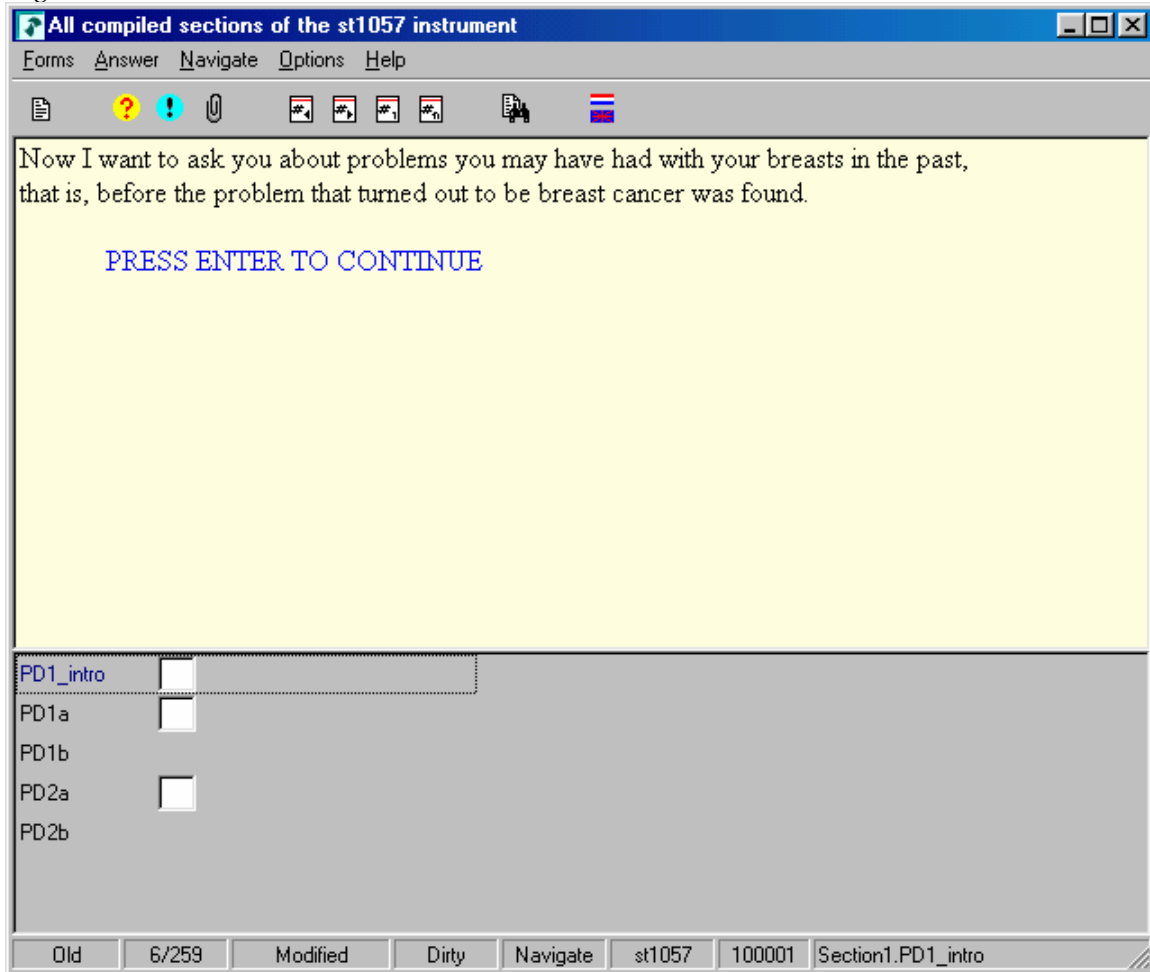

- 1) The menu bar – The bar consists of 5 drop down menus; Forms, Answer, Navigate, Options, and Help. Clicking on any one of these titles will display a list of options that you may need/want to use during the interview session. Any option grayed-out is not activated for use on that particular screen. Active options may change from screen to screen (for example, the DK/RF options, which are available on most but not all screens).
- 2) The speed buttons – The second bar consists of several speed buttons that you may need/want to use during the interview session. Resting your mouse pointer on the speed button will display a description of what it does. Buttons include **Get form, Don't know answer, Refuse answer, Make Remark, Goto previous page, Goto next page, Goto first page, Goto last page, Search tag, and Form Language.**
- 3) The info pane – This is the portion of the screen shaded pale yellow. It will display the question text, interviewer instructions (in blue, and usually in all

capital letters), and answer choices. The text should be read/used as instructed in general and study specific training.

- 4) The form pane – This is the pale gray area at the bottom of the window. It contains one or more field panes or fields where the data is entered. Each field has a field name or variable name. On fields which display numbered response options, after you enter an answer a variable label will be displayed to the right of the entry for that field for reference as you view a page. (Numeric and string fields don't have such variable labels.) These labels can be useful when checking previous answers without having to scroll back through all fields one by one. Each form pane also corresponds to one page. You can use the mouse pointer or arrow keys to navigate one field at a time or use the “previous page” and “next page” speed buttons or the “page up” and “page down” keys to move backward and forward one screen/page at a time. NOTE: You will not be allowed to move past fields that are required to be answered (and that have not been answered yet).
- 5) The status bar – This is the last line on the screen that contains some information about the case. The three sections of particular interest are the second, which displays the current page/total pages involved in the interview (ex = “6/259”) and the last two, which display the current CaseID number (ex = “100001”) and the name of the field that the cursor is currently on (ex = “Section1.PD1\_intro”).

## **Accessing a case (“form”)**

- 1) After entering the Blaise system you will be brought to a screen that asks for CaseID number.
- 2) Enter the 6-digit CaseID number to access the form.

*Figure 8*

The screenshot shows a web browser window with the title "All compiled sections of the st1057 instrument". The browser's address bar and menu bar are visible. The main content area is a form with a large yellow text area labeled "Case Identification Number". Below this is a text input field labeled "CaseID". The bottom status bar shows "Get 1/1 Dirty Navigate Key page CaseID".

### **Entering answers**

You can use the keyboard to enter the answer to any question in the form. Simply enter the appropriate number(s) or letter(s) into the field pane and press the “Enter” key. This will take you to the next appropriate question.

Alternatively, questions such as those with radio buttons or check boxes, can be entered by clicking on the appropriate response. Clicking on the text of the response itself is the best way to ensure that the correct response is selected.

Whether using the keyboard or using the mouse to select answers it is always advisable to quickly glance at the screen to ensure that the correct response was selected.

*Closed ended (numbered response) questions:*

For those with radio buttons you use the keyboard to enter the number of the response and press the “Enter” key to move on to the next question. Or you can click once on the response to select it and press the “Enter” key to move on. Or you can double-click on the response to both select it and move to the next screen; but this is dangerous because it’s hard to catch any mistakes caused by double-clicking on a different response than the one you were aiming at.

*Figure 12*

All compiled sections of the st1057 instrument

Forms Answer Navigate Options Help

First, has a doctor or nurse ever told you that you had a non-cancerous condition in your breast, such as benign breast disease, fibrocystic breast disease, a lump or lumps in your breasts?

1. Yes

2. No

7. NO CODED RESPONSE APPLICABLE  
(LEAVE NOTE)

PD1\_intro

PD1a

PD1b

PD2a

PD2b

Old 6/259 Modified by rules Dirty Navigate st1057 100001 Section1.PD1a

**CAUTION:** if there are 2 or 3 columns of responses presented onscreen, and you use the mouse to select an option in the 2<sup>nd</sup> or 3<sup>rd</sup> column, you have to be careful not to click to the **left** of the radio button, or you may end up selecting the answer to the left of the one that you intended. This can be a hard error to catch if you are double-clicking in order to both select the response and move to the next screen. Clicking on the answer text just to the **right** of the radio button (that is, on the response number or label itself) may be the best way to avoid this error.



For those close ended questions with check all that apply boxes you can check the boxes in any order by clicking on each box in the order the response is given by the respondent. Or you can use the keyboard to enter each response separated by a dash. For example,

1-3-2-10

would indicate that the first, third, second and tenth answer categories from the list were named by the respondent in that order.

**CAUTION:** If you are using the keyboard instead of the mouse to enter responses the program will allow you to enter the same option twice (for example “1-3-1”, entering option “1” twice), but you will get an error message when you try to proceed.

Figure 13

All compiled sections of the st1057 instrument

Forms Answer Navigate Options Help

Did you have asthma, high blood pressure, diabetes, heart disease, or something else?

(RECORD ALL MENTIONS)

1. Asthma  10. OSTEOPOROSIS

2. High blood pressure  95. SOMETHING ELSE (Specify on next item)

3. Diabetes

4. Heart disease

5. ARTHRITIS

6. BACK PROBLEMS

7. HIGH CHOLESTEROL

8. INJURY (BROKEN BONE, ETC.)

9. MENOPAUSE-RELATED

CH1a	2	No
CH1b1	2	No
CH1b2	2	No
CH1c	1	Yes
CH1c1	1-3-2-10	
CH1c1_txt		

Old 88/259 Modified Dirty Navigate st1057 100001 Section2.CH1c1[1]

**CAUTION:** For “check all that apply” questions a “don’t know” response or a “refusal” response is intended to be used as the only answer to the question. It may not be used in conjunction with checking other responses shown on the screen. If other responses have been entered followed by the don’t know or refusal option, the previous entries will be erased, so if you want to preserve those other answers you should enter the don’t know or refusal answer as a “SOMETHING ELSE” or “OTHER” answer with an appropriate message in the follow-up field (“Refused to say what the other illness was”, or whatever).

**CAUTION:** For “check all that apply” questions be careful when backing up to edit or append to an answer. When you back up the entire answer field will be highlighted.

1-3-2-10

Typing in any answer while the field is highlighted will overwrite the previous answer(s). To edit or append to the field you can press the “Insert” key or click with the mouse on the answer field and then edit as desired.

**CAUTION:** as with radio button responses, check boxes that are arrayed in 2 or 3 columns can result in data entry errors when you click to the **left** of the item you intended to select. Clicking on the answer text just to the **right** of the radio button may be the best way to avoid this error.

*“Don’t know” answers:*

“Don’t know” is not displayed on-screen as a potential answer category but it is available for use on most questions. It can be selected by entering the key combination “Ctrl” + “k”, or by clicking the “Don’t know answer” speed button, or by choosing “Don’t Know” from the “Answer” menu on the menu bar. The answer is displayed on-screen in the field pane as a yellow circle with a question mark in the middle.

If “don’t know” is not available for a particular item, you will be notified by an onscreen interviewer instruction indicating “(NODK)”. If you try to use the Ctrl-K shortcut, or the speed button, on such items, you won’t get an error message; instead nothing will happen. You can also tell that the option is unavailable because both the “Answer” menu option and the speed button will be grayed out.

If “don’t know” is not available for an item, you can assume that this was intentional and that you should probe further to get the R to choose one of the other precodes.

If the R gives an answer that doesn’t fit into one of the existing codes, and when probed, can’t pick one of those pre-codes, do not code this as a “don’t know” answer but instead select a precode and leave a remark.

You can review all of your “don’t know” answers by selecting the “Show DontKnow and Refusal” option on the “Navigate” menu. (It displays both “don’t know” and “refusal” answers by default, but you can uncheck the “Show refusal” check-box.) To go to an item answered with a “don’t know” (if for example the respondent now has an answer), select that item in the left screen of the dialog box and then click on the “Goto” button.

Figure 14

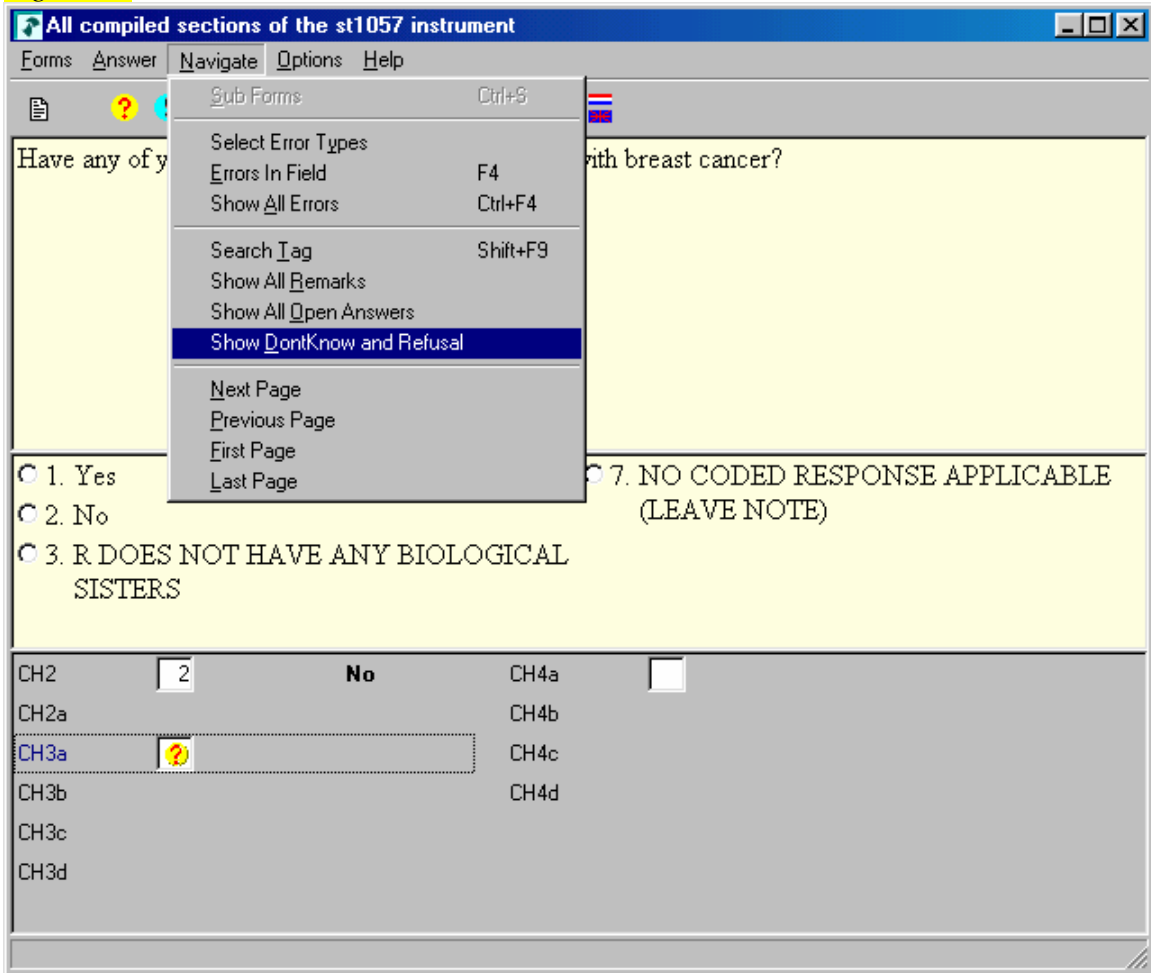
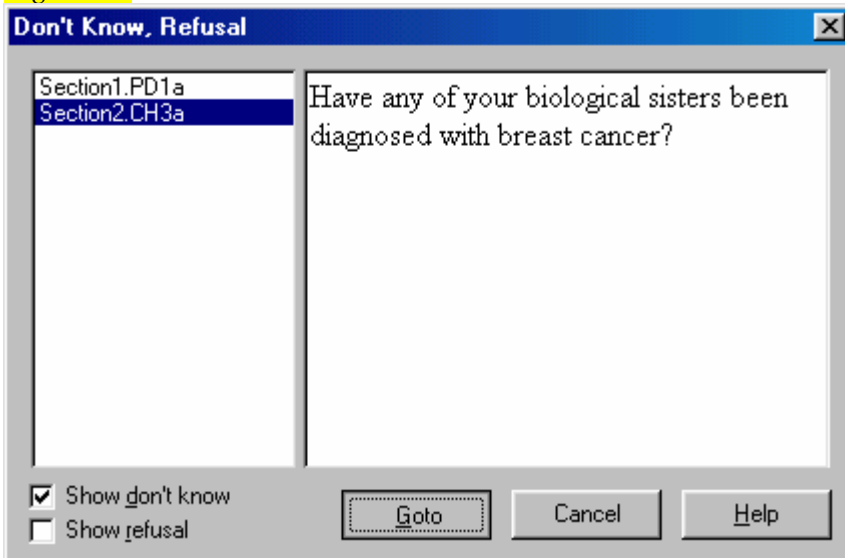

Figure 15



### *“Refusal” answers:*

“Refusal” is not displayed on-screen as a potential answer category but it is available for use on most questions. It can be selected by entering the key combination “Ctrl” + “r”, or by clicking the “Refuse answer” speed button, or by choosing “Refuse” from the “Answer” menu on the menu bar. The answer is displayed on-screen in the field pane as a blue circle with an exclamation point in the middle.

If “refusal” is not available for a particular item, you will be notified by an onscreen interviewer instruction indicating “(NORF)”. If you try to use the Ctrl-R shortcut on such items, you won’t get an error message; instead nothing will happen. You can also tell that the option is unavailable because both the “Answer” menu option and the speed button will be grayed out.

If “refusal” is not available for an item, you can assume that this was intentional and that you should probe further to get the R to choose one of the other pre-codes, emphasizing the confidentiality of the information as appropriate.

If the R gives an answer that doesn’t fit into one of the existing codes, and when probed, refuses to pick one of those pre-codes, do not code this as a “refusal” answer but instead select a precode and leave a remark.

You can review all of your “refusal” answers by selecting the “Show DontKnow and Refusal” option on the “Navigate” menu. (It displays both “don’t know” and “refusal” answers by default, but you can uncheck the “Show don’t know” check-box.) To go to an item answered with a “refusal” (if for example the respondent now has an answer), select that item in the left screen of the dialog box and then click on the “Goto” button.

### *Entering a note/remark:*

You can enter an interviewer note on any item by entering the key combination “Ctrl” + “m”, or by clicking the “Make remark” speed button, or by choosing the “Make Remark” option from the “Answer” menu. This will bring up a “Remark” box for you to type into.

*Figure 16*

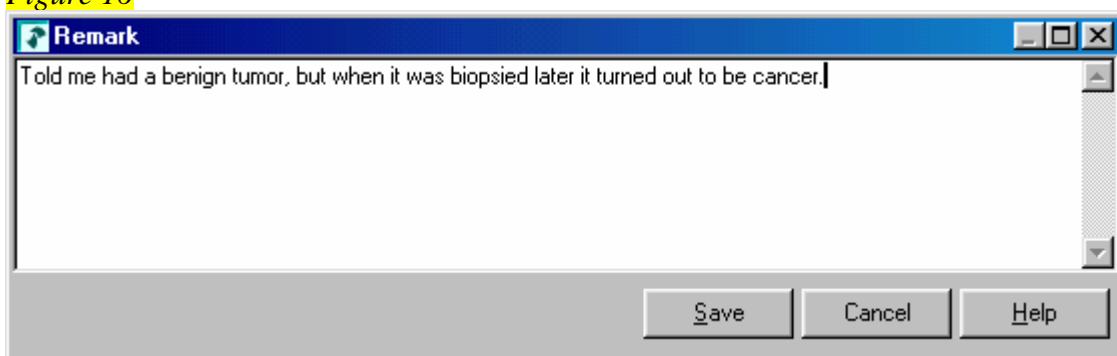

**CAUTION:** Be sure to click on the “save” button to save your text. If you press the “cancel” button, or otherwise close the Remark box without saving (by, for example, clicking on the “X” in the corner), any text you just entered will be erased.

Once you have saved the remark a paper clip symbol will appear on the screen to the left of the field pane. To view and edit your saved answer, you can open the remark the same way you did before (from shortcut keys, speed button, or menu), or you can double-click on the paper clip icon beside the question. To delete a remark you have to delete all of the remark's text (open the remark, delete all of the text<sup>1</sup>, then click on the "Save" button); once the remark has been deleted the paper clip symbol for that remark will disappear.

You can review all of your remarks by selecting the "Show All Remarks" option on the "Navigate" menu. To go to an item that has a remarks attached to it (if for example the respondent's current answer requires editing a previous note), select that item in the left screen of the dialog box and then click on the "Goto" button. Once you're at the item, open the remark in order to view and edit it.

Please note: It may be appropriate at times to make a remark in conjunction with precodes other than "NO CODED RESPONSE APPLICABLE". A remark can be left on any screen where you feel a remark is needed based on instruction you received in general or study specific training.

#### *String questions:*

These are limited-text-entry questions (unlike the "open ended" questions mentioned below). They are often used for names and addresses, and usually provide between 40 and 80 characters for data entry.

You may occasionally run out of space to record your answer on a string question (if for example you get an address longer than 80 characters on an 80-character string question). In those cases you can enter the rest of the data in a remark attached to the string question. For something like an address, you might want to start the remark by indicating that you ran out of space to record it; then copy the text already entered for the string question and paste it into the remark<sup>2</sup>, before continuing to enter the rest of the address in

---

<sup>1</sup> You can delete the text in any of several different ways (and the list below is not exhaustive):

- a) From the end of the text (arrived at by pressing the "Ctrl" + "End" keys), press the "**BkSp**" key until you've deleted the text all the way to the beginning.
- b) Or, from the start of the text (arrived at by pressing the "Ctrl" + "Home" keys), press the "**Del**" key until you've deleted the text all the way to the end.
- c) Or, from the start of the text (press "Ctrl" + "Home"), select all of the text to the end by pressing the "**Shift**" + "**Ctrl**" + "**End**" keys, and delete the selected text by pressing the "**Del**" key.
- d) Or, from the end of the text (press "Ctrl" + "End"), select all of the text to the beginning by pressing the "**Shift**" + "**Ctrl**" + "**Home**" keys, and delete the selected text by pressing the "**Del**" key.
- e) **Or, use the mouse** to select text starting from either the beginning or the end of the text by pointing, left-clicking, and then, with the mouse left pad held down, moving the mouse pointer to the other end of the text. Then delete the selected text by pressing the "**Del**" key.

<sup>2</sup>To copy and paste the string answer into the remark:

- a) Select the text already entered for the string question, in any of the following ways...

the remark. (Do **not** manually re-type the string answer into the remark, since any differences between the two will create a puzzle as to which is the correct version; use copy-paste as described in the footnote.)

Note that the entry of “don’t know” and “refusal” answers for string questions is done in the same way as for close-ended questions.

*Open ended (memo) questions:*

These are **unlimited**-text-entry questions (unlike the “string” questions mentioned above), although they look just like a string question until you start to enter data. They are used in places where the respondent might give us an entire story (for example, when we ask “what did the doctor tell you to do next?”).

To enter data, you can either just begin typing, or double-click, or press the “Insert” key. The system will bring up a memo box that allows you to enter a virtually unlimited amount of text. (The box looks and acts much like the one that comes up for remarks.)

*Figure 17*

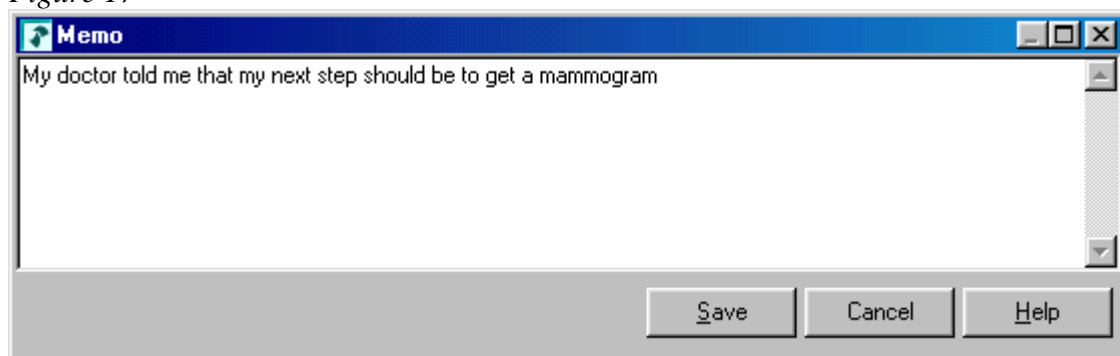

- 1) Back up to previous item (using up arrow key), then go forward again to string question (using down arrow key), which will automatically highlight (select) all of the text you’ve entered for that string question.
  - 2) Or, from from the start of the string question text (arrived at by pressing the “Home” key), select all of the text to the end in one step by pressing the “**Shift**” + “**End**” keys.
  - 3) Or, from the end of the text (arrived at by pressing the “End” key), select all of the text to the beginning in one step by pressing the “**Shift**” + “**Home**” keys.
  - 4) Or, from the start of the text (press “Home”), select all of the text to the end, character by character, by pressing the “**Shift**” key and continuing to press the **right arrow key** till you’ve arrived at the end.
  - 5) Or, from the end of the text (press “End”), select all of the text to the beginning, character by character, by pressing the “**Shift**” key and continuing to press the **left arrow key** till you’ve arrived at the beginning.
  - 6) Or, **use the mouse** to select text starting from either the beginning or the end of the text by pointing, left-clicking, and then, with the mouse left button held down, moving the mouse pointer to the other end of the text.
- b) After selecting the text, copy it to the clipboard by right-clicking and selecting “Copy” from the menu, or by pressing the “Ctrl” + “C” shortcut keys.
  - c) To paste the selected text, open the Remark and either right-click and select “Paste” from the menu, or press the “Ctrl” + “V” shortcut keys.

CAUTION: Be sure to click on the “save” button to save your text. If you press the “cancel” button, or otherwise close the Memo box without saving (by, for example, clicking on the “X” in the corner), any text you just entered will be erased.

You can back up to this open ended question at any time to view and edit your saved answer (but see the “CAUTION” below). You can also review all of your answers to open ended questions by selecting the “Show All Open Answers” option on the “Navigate” menu. To go to one of these open ended questions (if for example the respondent’s current answer requires editing a previous answer), select that item in the left screen of the dialog box and then click on the “Goto” button.

CAUTION: To edit an existing Memo-type (open ended) answer, you need to double-click on it or press the “Insert” key after your cursor is on the answer. If instead you start typing, or click **once** in the answer and start typing, you will end up deleting the text that was previously there.

Note that the entry of “don’t know” and “refusal” answers for open ended questions is done in the same way as for close-ended questions.

#### *Introduction screens:*

These are screens on which some introductory text is read to the respondent, and you are instructed to “PRESS ENTER TO CONTINUE” after you are done, without having to enter any data. The screens will **accept** a single character of data if you enter it, but this will not be stored in the final dataset, so it’s not a problem.

#### **Edit check screens:**

Edit check screens will pop up either when a data entry error has clearly been made (a “hard” error which requires a change to an answer entered), or when an error is suspected (a “signal” which can be suppressed by the interviewer).

For example, an interviewer may record that the respondent’s first live birth was at age “18” (DM21c1=18), and that her last live birth was at age “17” (DM21c2 = 17)...perhaps because of a typo of “17” when “27” was meant. Clearly her last live birth must have been at a later age than her first live birth, and this is therefore an example of a hard error. The edit check programmed to catch such an error would bring up a popup window like the following:

Figure 24

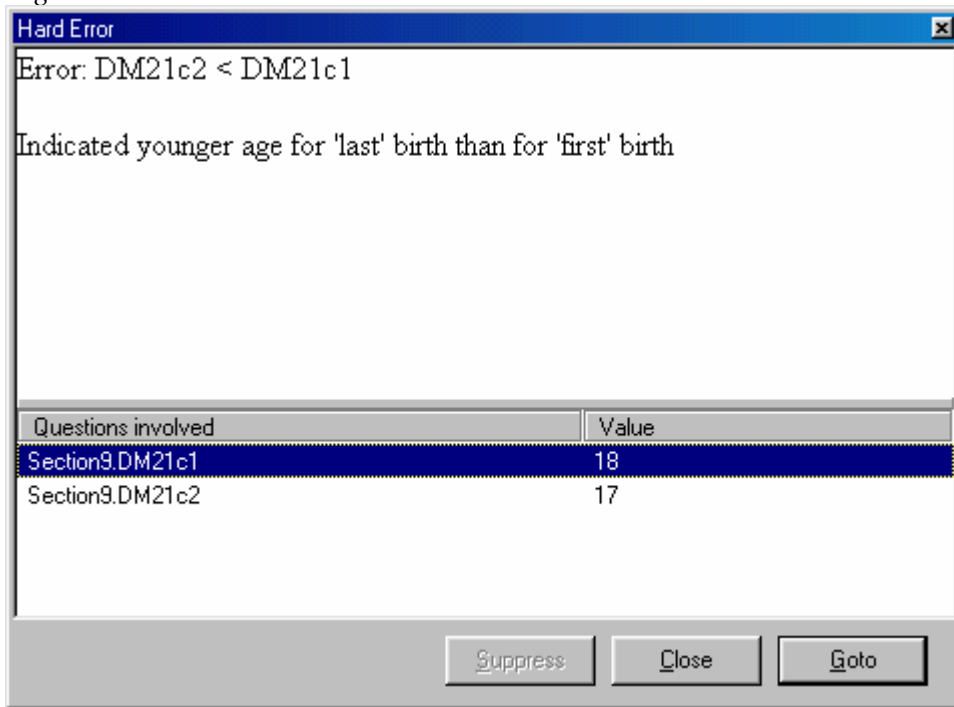

Notice that the “Suppress” button is greyed out. This popup will only go away when the interviewer returns to one of the two questions and changes the answer so that the inconsistency is eliminated. (For example, by selecting the “Section9.DM21c2” item, clicking on the “Goto” button, and changing that answer from “17” to “27” before proceeding to the next question.)



On the other hand, an interviewer **can** suppress a “signal” generated by an edit check of a suspicious answer. Suppressing a “signal” confirms that the suspicious answer is in fact correct; the “signal” popup window therefore goes away and the interviewer is allowed to proceed to the next question.

For example, an interviewer may record that the respondent spends “0” hours awake with her spouse on an average weekday (NT5a=0). This is an unusual answer, but not impossible (since some spouses live apart for work reasons during the week, and get together only on weekends). The edit check programmed to query interviewers about such an unusual but possible answer would bring up a popup window like the following:

*Figure 25*

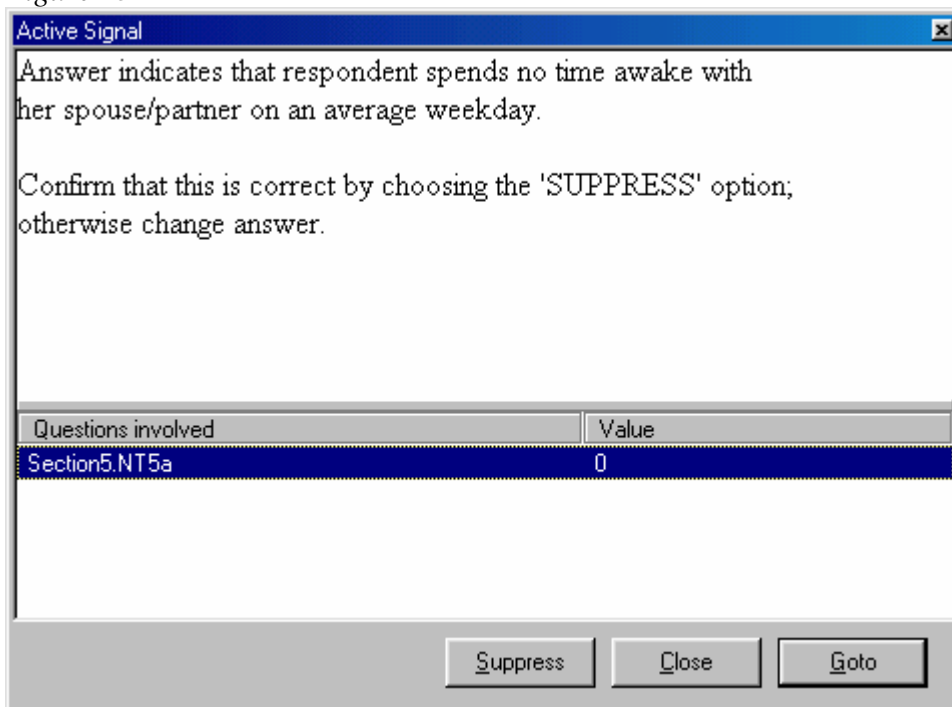

Note that such an interviewer “signal” can be suppressed if the answer entered was indeed the correct one (by clicking on the “Suppress” button). If on the other hand the answer entered turns out to be incorrect (due perhaps to a typo of “0” when “10” was meant), the interviewer can return to the question by clicking on the “Goto” or the “Close” button, and then change the answer before proceeding to the next question.

### **Exiting and saving a form**

You can exit a form in several ways at any point in the interview for a partial interview or at the end.

After the last question in the questionnaire is asked and answered you will be asked if you want to save the form or cancel. If you click on the “cancel” button you will be put back in the questionnaire form. If you click on the “Yes” button your form will be saved and closed.

You can also exit a form at any point by selecting the “Forms” menu option “Close” (to close the form but remain in Blaise) or “Exit” (to both close the form and exit Blaise). Clicking on the “x” box in the upper corner of the Blaise window has the same effect as choosing “Exit” (it closes the form and exits Blaise). In all cases, you will be prompted with the same options as when you complete a form: to either save and exit the form or cancel the exit procedure and return to the form.

#### **CAUTION:**

You must enter a “1” on the last “End\_All” item (as it tells you to) before exiting. If instead you get to the “End\_All” item and just exit the program, the case will not be treated as a completion but as a partial. So the safest way to exit a completed case is to answer all of the questions, including “End\_All”, and press enter so that the program prompts you to save the form.

# **QAPP 2**

## **Appendix 1E**

### **CHEERS Survey Training Manual**

#### **How to do a CAWs Use Survey**

## **HOW TO DO A CAWs USE SURVEY?**

Specific aims of the CAWs usage survey are to determine:

- CAWs usage, in terms of numbers of users and types of recreational activities at various access points.
- To identify differences in usage between locations
- To identify differences in usage at the same location at different times of day, and different days of the week.
- To identify use at informal access points.

The procedure of the CAWs usage survey will be as follows:

- a. The CHEERS Field Manager/Supervisor or the on-site Data Manager will have overall responsibility for identifying sites and times to start sampling as well as for conducting user counts. Only field staff trained in this protocol will conduct this CAWs use survey.
- b. Staff will select a clear view of the access point of interest, preferably in a shaded location. They will fill out the top half of the CAWs Use Survey Data Sheet.
- c. Using the datasheet, staff will tally the number of individuals who begin recreation, by recreational activity. The tally will be done in 10-minute intervals. The first interval will begin at 0, 10, 20, 30, 40, or 50 minutes past the hour. Staff will write into the chart the hour (clock time) for each interval.
- d. In order to avoid counting the same individual more than once, individuals will be counted only when they begin a recreational activity. Those recreating at the time that counting begins will be identified by circling the tally marks for those individuals.
- e. After a datasheet has been completed, staff will begin a second sheet, taking care to again complete the top portion, including the page number.
- f. Consent: Because this is a study of the behavior of anonymous individuals in a public space this study has been granted exempt status by the UIC Institutional Review Board (IRB) for the protection of research subjects. Thus no consent

process for the CAWs recreational use study is necessary and none will be performed.

- g. Safety of the researchers will be maintained at all times. The field study will not be done without adequate light and will be terminated in the event of inclement weather. Researchers will also be instructed to leave the area and seek a safe location in the event that they feel that their safety is threatened in anyway.
- h. At the completion of data collection, data sheets will be given to the on-site Data Manager.

# **QAPP 2**

## **Appendix 1F**

### **CHEERS Survey Training Manual**

#### **Know Your Job**

## **KNOW YOUR JOB**

### Scheduling

Your schedule is planned around your availability, classes and activities and within the framework of our study. Some schedules may stay the same during the entire season, while others may change on a regular basis. You will be scheduled to work Fri/Sat or Sun. We require you to sign up for a minimum of 12 hours of work each week. You may work as many hours as allowed by the university and at the discretion of the study coordinators. Please ask your supervisor for further details. If you have a conflict due to vacation, classes, activities or any other reason, please see Sara and let her know in advance. We will assist you in resolving conflicts with your work schedule. Due to the nature of this study you will probably be required to work holidays and during exam periods. Every effort will be made to accommodate course work and other activities, however a definite commitment in time and availability will be required during the periods of active sampling in the study.

### Pay Day

All employees are paid on a bi-monthly basis. Earnings are directly deposited into the bank account you designated on the NESSIE new hire forms.

Employees are responsible for filling out a time card after each shift which will be signed by the immediate supervisor. If you believe there is an error in your paycheck, please bring it to the attention of the project coordinator immediately.

### Evaluations

Your work performance will be evaluated periodically throughout the season. You will also be given an opportunity to give us feedback.

### Resignations

In the unfortunate event that you have to leave your position, please see Amelia/Preethi or Sara BEFORE you resign. We may be able to help you work out the conflict. If you are sure that you must resign, however, we ask that you give us at least two (2) weeks advance notice. This will allow you to remain eligible for future employment. In addition, this courtesy will give supervisors and coworkers time to replace your shifts.

## **YOUR WORK DAY**

### Rest Periods

You can ask for two (15) minute rest periods when you work at least six consecutive hours. This includes a meal/rest room/phone call break (and smoking breaks too). Your supervisor/field manager/data manager will determine when your breaks may be taken. We encourage you to eat prior to, or at the end of your shifts. Also note, many of the recruiting sites are in relatively remote areas and do not have restaurants or food establishments nearby. Plan to bring food if you need to eat during your workday.

## Training and Supervision

You will be trained in all aspects of your job prior to be sent into the field. Our supervisors/field managers/data managers will then provide further assistance when in the field. We will teach you the proper techniques and safety procedures to ensure that you will be successful in your job. If you are not sure of something during the course of your work day, please see your supervisor/field manager/data manager.

## Reporting for your shift

1. You are expected to report to work on time as scheduled. Please do not arrive late.
2. Arrive at work wearing your CHEERS T-shirt and ready to work.
3. Please be prepared to work your entire shift
4. Complete your time card and submit to the immediate supervisor at the end of each shift. Over reporting of time worked will require disciplinary action.

## **EMPLOYMENT POLICIES**

Every job is important and yours is no exception. It is necessary that you report to work according to your schedule.

- If you are scheduled to work and are unable to do so (for example: you become ill or there is a schedule conflict), you are responsible for finding a substitute who is capable of performing your job. A list of coworkers' phone numbers is posted on the CHEERS website (blackboard).
- If you fail to report to work without finding a substitute, the absence will be unexcused. Unexcused absences may result in termination and a negative evaluation.
- If you are ill and unable to work, we may require you to provide verification from your doctor.
- If you might be late for work, inform your supervisor/field manager/data manager on the schedule for that day. Failure to do so may result in disciplinary action.
- Major emergencies or illnesses will be taken into consideration on an individual basis. Discuss such situation with us.
- Remember, we try to be FLEXIBLE. Keep us informed and you will remain in good standing.
- You will be provided with two CHEERS T-shirts which should be worn during every shift. We expect you to look clean, neat and professional at all times. You can always ask for replacement T-shirts and for any questions about what is appropriate to keep yourself looking great!
- It is unlawful to manufacture, distribute or possess a controlled substance while working for UIC. Working while under the influence of drugs or alcohol is prohibited and will result in termination. All employees are prohibited from carrying out any box, package or container from their workplace without prior consent. Those employees who do not follow this policy will be subject to appropriate discipline, which may include termination. Lost and abandoned



items should be reported to your supervisor.

- As a member of the CHEERS study team, your success during the course of your employment is important to us. Work rules are established and are expected to be followed. Your unit will also express additional expectations to you.

### **Safety Rules / Regulations**

As an employee, you share in the responsibility for the health and safety of yourself, your coworkers, study participants, and other members of the community.

- Follow the Cheers study safety plan at all times.
- Wash your hands or use hand sanitizer after using the rest room, coughing, sneezing, touching your hair, eating or wiping your face.
- Report unsafe working conditions to a supervisor/field manager/data manager.
- If you are injured on the job, regardless of the degree of severity, notify us immediately. Your supervisor will see that you get medical attention if necessary.

### **Quality Control**

A lot of information will be presented during the training period. All this information is designed to provide to you the tools, knowledge and experience necessary to be the best interviewer that you can be. The study relies on the accuracy of the data collected during all parts of the survey. It is very important that data collected is not biased or accidentally misrepresented at any time.

The Assistant Study Director- Surveys, CHEERS Assistant Research Specialists, Study Director, Program Coordinator and field supervisors will monitor each interviewer in the field to receive effective feedback on the performance. Interviewers may not know when or how they are being monitored. Monitoring is done in the field while an interviewer is recruiting participants and administering questionnaires or through the data collected in a survey. The CHEERS surveys have certain built-in checks that help us monitor the data quality by interviewer.

Monitoring is more heavily concentrated during the early phases of data collection and for newly-hired interviewers so that any problems in performance can be detected immediately. The monitor is instructed regarding whom and when to monitor based on random selection of interviewing stations and times during each field shift or as a result of problems noted from previous monitoring sessions.

This ongoing monitoring of CATI interview files permits interviewer skills to be evaluated in a number of key areas, including the ability to follow instructions correctly and the ability to

probe for clear and complete answers. Through monitoring, additional factors, including the interviewer's skills in eliciting cooperation and maintaining neutrality, are routinely evaluated. Errors detected during these reviews are recorded on a standardized form to help supervisors give feedback to interviewers and retrain as necessary. Positive as well as negative feedback is given to ensure that the interviewers maintain a high level of commitment to quality.

## Falsifying Data Collection

Intentionally falsifying data collection is illegal and unethical and will compromise the reliability of the study. All of your work is to be performed in a faithful, industrious, and professional manner in accordance with the code of conduct specifically established for the CHEERS study. Your work must be authentic. CHEERS may validate your work by contacting respondents and you are expected to cooperate with these validation efforts. CHEERS used internal and external checks to validate data collection in 2007 and will continue to do so in 2008.

It is unethical and fraudulent to submit any work that you represent as data that you have collected from sample respondents, when you have not, in fact, done so. Any violation may result in termination of employment and may violate IRB rules regarding scientific integrity. A violation may also lead to other actions by CHEERS, such as criminal court action and claims for money damages.

## **Interacting with the Media Press**

We are not the experts on this survey. We are their means of acquiring data and are not the spokespersons of CHEERS. The CHEERS representatives are the scientists involved with this study. Dr. Samuel Dorevitch (Study Director), Dr. Preethi Pratap (Assistant Study Director - Surveys), Sara Wuellner (Program Coordinator), Amelia DeLaquil (Assistant Research Specialist) and Todd Schoonover (Field Logistics Coordinator) are the CHEERS staff authorized and prepared to answer any and all questions any representative of the media should have.

## Tips for Handling the Press

- Don't Panic: The media are people too. Be calm, if you're in the middle of an interview finish the interview and politely speak with the media person.

- **Be Polite:** Politely explain to the media person that you're job is to conduct interviews and that the principal investigator or a supervisor will be able to more accurately answer their questions. Direct the media person to Sam or to the supervisor available at your location.
- **Be Proactive:** If you see a media person looking for someone to interview, direct them to either Sam or to a supervisor.

# **QAPP 2**

## **Appendix 1G**

### **CHEERS Survey Training Manual**

#### **Professionalism Policy**

## **CHEERS Professionalism Policy:**

It is the study's expectation that all employees will conduct themselves according to high standards of conduct and performance. Our work takes place in the public arena, and unprofessional behavior can impair our ability to collect high quality data, damage to the study's image in the eyes of public, and promote discord within the project team. When employees do not behave professionally, it is the immediate supervisor's responsibility to act in a timely manner and initiate a program of disciplinary steps to address the problem. This policy presents the basic principles and procedures of a system of progressive discipline which is intended to ensure that all employees are treated as consistently and fairly as possible. The disciplinary program has four major purposes:

- To ensure that the employee knows what the problem is
- To communicate what the supervisor's expectations are in order for the employee to correct the problem
- To provide appropriate penalties for improper work conduct
- To provide a record of corrective action taken by supervisors in such problem situations.

### Progressive Discipline

Progressive discipline is a formal process which includes several steps or levels of discipline, each of which provides the employee with the opportunity to correct the problem or inadequacy.

A. Preliminary Actions. Prior to moving to formal discipline the supervisor should do the following:

1. Do a thorough fact-finding which includes collection of all information and applicable records. This will be done by the Field supervisor and Survey Managers.
2. Hold a discussion in private with the employee. During the discussion the supervisor should state the problem clearly and allow the employee to respond.
3. Follow up with the employee after the meeting and after all information has been gathered, to report the findings. If the supervisor intends to move to formal discipline, the employee should be told at the conclusion of the follow-up meeting or as soon after as possible. It should be made clear to the employee which level or step of the discipline process is being applied.
4. Provide a follow up letter as soon after the meeting as possible. The letter should include the date and time of the follow-up meeting, a brief statement of the problem, the supervisor's expectations, and the conclusion reached in the meeting. The stage of discipline must be clearly noted and a statement made that lack of improvement will result in further discipline.

B. The Steps of Progressive Discipline. There are *four steps* in the progressive discipline process; however, in cases of misconduct or repeated infractions, the process may be

shortened and the supervisor, in consultation with the Principal investigator, may move directly to a later step in the process, including termination.

All disciplinary action should be taken within a reasonable time frame it is recommended that no more than two days elapse between the time the supervisor learns or has knowledge of the offense and the action is taken.

The standards of professionalism differentiate between minor and significant violations. Examples of minor violations of standards of professionalism include:

- Not wearing the CHEERS t-shirt while working
- Speaking on a cell phone while working (meaning, while not on a break scheduled by a supervisor)
- Arriving more than 15 minutes late to the study location
- Smoking at or adjacent to the study location

Examples of significant violations of standards of professionalisms include:

- Failure to show-up to work without arranging a shift swap or notifying the supervisor the day before
- Arguing with or making inappropriate comment to study participants
- Insulting study participants
- Theft
- Refusal to perform work
- Falsifying data collection

### 1. Oral Warning

Oral warnings are appropriate for minor first offenses. It is important that supervisors not overuse the oral warning for the same type of offense; no more than two oral warnings should be given.

The supervisor should have a full discussion with the employee before giving the warning to ensure that the employee has the opportunity to respond or to give additional information. If the supervisor believes that an oral warning is appropriate, it should be made clear to the employee that the oral warning is the first step in the progressive discipline process. The oral warning should be *documented* for the supervisor's record and it is recommended that a note summarizing the warning be given to the employee. The record and note should record the date, time and reason for the warning. This will be done by the Field Supervisor or Survey Manager.

*Note: The oral warning remains in effect for 2 months.*

### 2. Written Warning

After an employee has received an oral warning, a subsequent minor offense should be addressed by a written reprimand as appropriate. Arriving more than 30 minutes late will also result in a written warning. When a field supervisor notes such an offence, his/her manager (survey manager, field manager) must review the draft of the written reprimand with the Principal Investigator. The supervisor and employee first meet to

discuss the problem. In the discussion, the supervisor must review the incident or performance problem which requires the reprimand and the supervisor and employee should exchange ideas and information regarding solution(s) to the problem. The written reprimand should be given to the employee directly following the discussion. Employees can provide a written response to the warning within two (2) days of receiving the warning and both documents will be placed in the employee's official personnel file.

The written warning should:

- Be identified as a disciplinary warning
- Describe as specifically as possible the situation which prompted the warning, including day, date, time, location, and what the supervisor saw or heard
- Indicate why the behavior or performance is unacceptable
- Review the decisions that were reached during the discussion regarding how the employee would correct the problem
- State that if the behavior continues or other problems occur, additional corrective measures may be taken, which may result in termination of employment.
- The supervisor should discuss the matter with the employee when giving the employee the warning.

*Note: The written warning can be given without a prior discussion regarding the incident between the supervisor and employee.*

Written warnings are retained in the employee's formal record.

### 3. Suspension

Suspension is the third step of the disciplinary procedure. It is intended to indicate to the employee the seriousness of the infraction and that the employee can reasonably expect that the next step is termination of employment. Suspension is an appropriate response to arguing with study participants, engaging in unsafe or illegal activities, intoxication, or more than one failure to show up for work.

Before determining if an employee should be suspended, *the supervisor must meet with the employee* to discuss the incident or problem and consult with the Principal Investigator. The employee should be notified in writing of the suspension as soon as possible and given two (2) days to respond. The letter should outline the reason for the suspension and the dates of the suspension. Suspensions are normally for three (3) to five (5) consecutive work days and the dates are determined by the supervisor in consultation with the Principal investigator and program coordinator. Longer suspensions because of severe infractions may be given and scheduled at the convenience of management. The employee should be warned that continuation of the behavior may result in termination of employment.

Suspensions are without pay. There may be instances when a final written warning may be more appropriate, and may, upon consultation with the Principal Investigator, substitute for a suspension (for example when discipline is for a pattern of absenteeism).

### 4. Termination

Termination of employment is the culmination of the progressive discipline process or the penalty for very serious offenses such as theft or violence. Whenever possible, the

Principal Investigator, Field Manager, Project Manager, Survey Manager, or Quality Control Manager should conduct a *pre-termination* hearing. The purpose of the hearing is to review with the employee's supervisor and the employee, the past record and any new circumstances leading to the supervisor's request to terminate.

Termination Procedure:

The Supervisor or Survey Manager will provide the pre-termination panel and the employee with any oral warning(s), any written warning(s), and a written statement outlining the reason for termination. A Minimum of two (2) days should be given to the employee to provide a written response to the panel. The panel may then either schedule a meeting or provide an immediate decision as to the appropriate course of action. In either case an action should be taken within fourteen (14) days of the initiation of the procedure.

*Note: Typically the employee will be suspended without pay during the time of this review*



# **QAPP 2**

## **Appendix 1H**

### **CHEERS Survey Training Manual**

### **Survey Training Manual**

## CHEERS Survey Training Manual Documents (2008)

1. CHEERS Survey Methods power-point presentation
2. Professionalism Policy
3. Know your job
4. Standards and Ethics in research
5. Survey Research Lab (SRL) CD
6. Recruiting:
  - a. Script,
  - b. FAQ sheet
  - c. Water Quality info. sheet
  - d. Mobile recruiting
7. Eligibility screener and Refusal Tally
8. Informed Consent:
  - a. Consent/Assent/Parental Consent
  - b. How to consent document
9. CAWs Use Survey:
  - a. How to conduct a use survey
10. Field surveys:
  - a. Refusal Aversion Exercise
  - b. Probing
  - c. Gaining Cooperation
11. BLAISE Manual
12. Mock Interviews (using laptops)
13. CHEERS job descriptions:
  - a. Recruiter
  - b. Interviewer
  - c. Incentive Person
  - d. Data Manager

# **QAPP 2**

## **Appendix 1I**

### **CHEERS Survey Training Manual**

#### **Consent Process**

## HOW TO CONSENT A CHEERS STUDY PARTICIPANT?

Please do take some time to read the consent/ assent and parental consent forms. If a participant is eligible to enroll in the study then you take them through the consent process.

1. All adults **18 years or older** will need to sign and date a CONSENT FORM.
2. All children **8-17 years old** will need a signed/dated PARENTAL CONSENT and also need to sign and date an ASSENT FORM.
3. All children **7 years and below** will need a PARENTAL CONSENT ONLY.
4. Please highlight the 5 main points in the consent form-
  - a. CHEERS is a voluntary research study. You can choose to quit any time you want. This will not affect your relationship with UIC at anytime.
  - b. You will complete a 3 minute Survey A, and a 5-7 minute Survey B. For this you will receive a \$15 Target gift card and a T-shirt. (Note: Water-recreators will need to return (mention time) before we leave for the day and complete Survey B. Only then will they receive the incentives). Tell them about the follow-up phone surveys 2, 5 and 21 days later. The phone surveys take about 6-8 minutes. We will ask them about their health. They will receive a \$35 check in the mail after the final phone call.  
***PARTICIPANTS CAN CHOOSE TO DONATE THE \$50( \$15 gift card + \$ 35 check) CASH INCENTIVE TO ANY CLUB/ORGANIZATION THAT HAS AN MoU WITH UIC. IF WE ARE NOT WORKING WITH A CLUB OR TEAM THEN PARTICIPANTS CAN ONLY DONATE TO: CHEERS STUDY OR FRIENDS OF THE CHICAGO RIVER.***
  - c. Participants may require a home visit if they do experience any skin, eye symptoms. A clinician will visit them at home and we may request a skin or eye swab. OR if participant experiences certain GI symptoms (stomach cramps, vomiting, diarrhea) they may be requested to provide a stool sample. If this happens they will receive an additional \$75.
  - d. The only risk to them is that we ask for their name, phone number and address. We will not share this information with anyone else. This information is used to contact them for the phone surveys and to send them their check. Once their participation is complete- we will only use the case id number (from the wristband) for the data analysis. Show them the wristband.
  - e. Finally, tell them page 4 of the consent form has a number where they can contact us with any questions or concerns about this study.
5. Participants will need to sign and date the consent form. Ensure you sign it and date it and store it in the black folder.
6. Strap one copy of the wrist band on their wrist and staple the other to the consent form. **Participants who lose their wrist bands cannot receive any incentives.**
7. Ensure you give them the first 4 pages of the consent forms.

**STUDY PURPOSE/STUDY QUESTIONS**

**1. What is CHEERS?**

- CHEERS is the "Chicago Health and Environment Exposure Recreation Study"

**2. "What's the purpose of this survey?" "I need more information."**

- Researchers at the University of Illinois Chicago, School of Public Health, want to better understand the connection between water quality and the health of people like you who are active in and around these waterways.
- This is a multi-year research project evaluating the health of people like you who use recreational waters such as Lake Michigan, the Chicago River and other waterways, for kayaking, boating, fishing and other non-water activities such as running, biking, golfing etc.
- Results from this study could be used for developing better environmental water quality standards to improve public health.
- This study is being funded by the Metropolitan Water Reclamation District of Greater Chicago

**3. Why can't swimmers be in this study?**

- Many research studies have evaluated the link between water quality and swimming. This study addresses other forms of water recreation. (Such as- mention participants proposed activity for the day)

**4. "What questions will you ask?"**

The questions asked are primarily about your activity for the day, other waterways you have recently used, your current health status, and some questions about food and pets. During the follow-up telephone survey we will ask you about any symptoms or illnesses you have experienced after your activity today.

**3. "And, what am I going to get out of this?"**

- It is your opportunity to have your input included in an important effort influencing policies and programs that may reduce pollution in recreational waters across the country and to protect recreators from illness.
- You can impact environmental conditions in your community and protect the future health of your family and other lake/river users.
- You will receive a t-shirt and a \$15 gift card today, followed by a \$35 check in the mail when you finish the final phone survey.

**5. "Why has River/Lake been singled out for these interviews?"**

- This study is being conducted for different waterways in the Chicago Area. We are recruiting people at Lake Michigan, Chicago River, Skokie Lagoons, Crystal Lake, Fox River, Desplaines River etc.....

**6. "What about beach water quality? What results are you seeing?"**

- The data is yet to be analyzed, but you can get more information about the water quality from these websites in this information sheet. Please hand out the Water quality Information sheet.

**7. "How long will the study last?"**

- The research study will last about 3 years. If you enroll in the research, your participation will last 3 weeks. Please note this does not mean every day. You will answer a few questions today and 2, 5 and 21 days from today.

## Training material: Not for distribution

### 8. "Can I participate later?"

- Yes, you can reach us at this number on the flyer. We will be at different locations on different days.

### 9. "If I volunteer to be in this study, what will I be asked to do?"

We will explain the study to you in detail and any questions you have will be answered. Then, we will ask you a few questions about your recent health and recreational activities to see if you are eligible to be in this study. If you still want to be in the study, we will ask you to sign a consent form to participate in this study for the next 3 weeks. Then-

- We will ask you a few questions before your activity today. This will take about 3 minutes.
- We will ask a few questions after your recreational activity and your current health. This will take about 7 minutes.
- We will call you 2, 5 and 21 days from today to ask you about how you feel. This will take about 6-8 minutes.

In addition, if you feel ill you **could be** selected for a home visit by a clinician in next 21 days or we may request a stool sample from you. Note: If participant needs more details you can direct them to a senior research staff member.

If you decide to participate, we will give you a T-shirt and a \$15 gift card after you have finished the surveys today.

At the end of 21 days of participation we will send you a \$35 check for your time and effort. We will also give you a check if you qualify for a home visit by a nurse or provide a stool sample.

**ALLEVIATING CONCERNS & FEARS/  
ASSURING CONFIDENTIALITY & LEGITIMACY**

10. **“What is going to happen to the information I give you?” OR “I don’t want to do this study and get on some mailing list.” OR “In this computer age, I just don’t trust who can gain access to my personal business.”**
- By law, all information you give is kept strictly confidential.
  - The information you provide is released only in summary form as statistical totals. (Your responses are added to the responses of others and published as combined information only.)
  - No individual responses or information that would permit the identification of any individual will be released or published.
  - All data is stored in password protected files or in locked cabinets.
  - All personal identifying information is removed and will not be disclosed or released to anyone for any purpose other than persons directly involved with the study, and we are all required to sign a statement of confidentiality regarding all information provided.
  - You will not be added to any mailing list.
11. **“I don’t know anyone who gets sick from the water, and this is something being blown out of proportion for you and the government people to have a job.”**
- Research studies such as this always welcome a cross-section of answers and opinions.
  - We don’t know if anybody gets sick from the water. This is what we are trying to find out.
- [BEAR WITH ARGUMENTATIVE RESPONDENTS WHO WISH TO “VENT.” THEY HAVE NOT REFUSED IF THEY ARE TALKING. DO NOT ARGUE; SIMPLY MAKE SHORT, NEUTRAL COMMENTS SO THEY KNOW YOU ARE LISTENING.]
12. **“No thanks. I’ve had a bad experience doing a phone survey.”**
- I’m sorry that you’ve had a bad experience. I would certainly hope that your experience with me would be a pleasant one. This is a special research effort and by participating in the study, you will help protect the future health of your family and other recreators.

## Training material: Not for distribution

### TIME/MAIL ME QUESTIONNAIRE

13. **“How long will this take?”**

- The amount of time varies from person to person, but it typically takes around 10 minutes.

14. **“I’ll be happy to do this if you send the questions to me in the mail.”**

- There is no paper questionnaire available because people are asked different questions based on the answers they give to previous questions. The computer selects the appropriate questions, which saves time.

### SPONSORS (CLIENTS)/INFORMATIONAL REQUESTS

15. **“Who do you work for?”**

I work for the University of Illinois Chicago, School of Public Health. The School of Public Health conducts studies and evaluations on many different topics related to the health and safety of the public.

16. **“Do you have a website?” “Can I get a copy of the study?”**

- You can contact Dr.Sam Dorevitch (Study Director), or Sara Wuellner (Program Coordinator) at 312-996-2094. Mention that you are calling about the CHEERS study.
- CHEERS website address is : \_\_\_\_\_

17. **IF ASKED A PERSONAL QUESTION:**

- I’m unable to discuss my own personal habits or opinions because they may bias your response and the study results. My job requires that I only ask the study questions.

18. **“What if I get sick after going in the water today?”**

- We will want to know about that. We’ll call you in 2,5, and 21 days from today. We’d want you to call us as well.
- We won’t be able to say if your water contact today made you sick, but by enrolling thousands of people , we will find out if in general , water contact is hazardous.

19. **“ Who will pay for my treatment, if I get sick?”**

- No injury is expected to occur as a result of your participation in this research. However, in the event of any illness that you develop after your water activity today we encourage you to follow your usual way of managing sickness in your family. UIC will not be responsible for diagnosis or treatment of illness that occurs in your family during participation in this study.



# **QAPP 2**

## **Appendix 1K**

### **CHEERS Survey Training Manual**

#### **For Mobile Recruiting**

For mobile recruiting:

1. Organize the mobile folders-
  - a. Consents ( All adults 18+)
  - b. Assents +Parental Consents (All children between 8-17 years)
  - c. Parental Consents only (All children 0-7 years)
  - d. Location flyers
  - e. Case IDs
  - f. Laptop and scanner
  - g. Stapler
  
2. Clipboard-
  - a. Eligibility screener and Refusal Tally sheet
  - b. Mobile Log (just a sheet of paper)- to track Case IDs with survey A and B
  
3. What to do?
  - a. Approach people (make sure fishermen are yet to start fishing)
    - i. Recruit
    - ii. Eligibility screener
    - iii. Record in refusal tally if ineligible or refused to participate
  - b. If eligible to participate
    - i. Consent participant
    - ii. Give Case ID number- one on the wrist and one on the consent form. Make sure participant gets first 4 pages of consent form. Secure signed consent with ID in the folder.
    - iii. Record Case ID given out in a log (JUST A SHEET OF PAPER)
    - iv. Administer survey
      1. Non-water recreators get both survey A and B
      2. Water recreators will get only survey A and will be asked to return to the CHEERS tent for Survey B.
  - c. Incentives- please note that all participants will have to return to the CHEERS tent to collect their incentives. Incentive person will have to make sure that participant has done Survey A and B before they hand out the gift card/t-shirt and stool flyer.
  - d. DM- You can send them out in groups of 2-3 (please monitor the process the first time). These are new interviewers and have minimal interview experience.
  - e. DM- Please review the consent process with them.
  - f. DM- Make sure all interviewers return the log (sheet of paper) with case IDs given out and the corresponding consent forms.



# **QAPP 2**

## **Appendix 1L**

### **CHEERS Survey Training Manual**

## **Instructions for Data Managers**

## Instructions for data manager

### DM responsibilities:

You will receive your assignment by time/location and date from Sara. There will be an option for you to sign-up as DM for each event.

Remember you are the immediate field supervisor in the field for the CHEERS staff.

- Arrive at the location at least 15 minutes before your schedule.
- Receive the supplies from the CHEERS Supply Manager/Driver for that day/location.
- Use the supplies checklist to ensure you have everything you need for that day/location.
- Fill out the time sheets for all staff.
- Each member is allowed 2 fifteen minute breaks in a 6-hour shift. Staff doing a 12-hour shift may take one 30 minute break and 2 fifteen minute breaks. Please read the 'CHEERS professionalism' and 'know-your-job' document to be familiar with the field rules for staff.
- Ensure all supplies are in place and safe.
- Count and account for the signed consent forms.
- Monitor the incentive process- count and account for the gift cards.
- Monitor the recruiting/interview process.
- Assign the CAWs use survey task to a CHEERS staff each time we visit a CAWS location.
- Ensure safe and accurate transfer/download of the data from the laptop to the flash drive.
- Complete the CHEERS field report form (see the sample form)
- Complete the DM task checklist (see sample checklist)
- Hand-over the following to the CHEERS Supply Manager/Drive at the end of the shift:
  - laptops,
  - flash drive,
  - used refusal tally sheets,
  - used incentive forms,
  - signed consents,
  - completed field report form
  - completed DM task checklist
  - completed CAWS use survey
- You can always call the CHEERS on-call senior staff if you have any questions or concerns.

### **Data Manager Survey Supplies List:**

The CHEERS Supplies Driver/Manager will give you the following supplies-

1. A paper rack
2. Data Manager Accordion file
  - a. Permits
  - b. CAWs Use Survey Forms
  - c. CHEERS Field Report form
  - d. Time sheets
  - e. FAQ sheet and Recruiting script of interviewers
  - f. CHEERS staff job description document
3. Black plastic “Signed consents” folder for storing consents and other documents.
4. A Log book to record Case ID, and status of Survey A/ B
5. A box of scanners
6. A box of pens, staplers/pins, bungee cords
7. A box of UNUSED back-up batteries for the laptops
8. An empty box to store DEAD/USED batteries.
9. Set of laptops
10. One flash drive
11. A roll of wrist band case IDs.
12. A box of gift cards
13. Boxes of t-shirts
14. Clipboards
15. Plastics file folders
  - a. Consents ( All adults 18+)
  - b. Assents +Parental Consents (All children between 8-17 years)
  - c. Parental Consents only (All children 0-7 years)
  - d. Water Quality Information sheets
  - e. Location specific flyers
  - f. Eligibility/Refusal Tally sheet
  - g. Incentive sheets
  - h. Stool flyers
16. Mobile recruiting folders (if necessary for that event or location)

In addition- each location will have a set of tables, chairs, tents, water cooler, and a CHEERS Study banner.

### **When you reach the site:**

1. Set up the tent and supplies
  - a. Arrange the papers and laptops on the table
  - b. Put up the CHEERS banner
2. Fill-out time sheets.
3. Announce the location to all CHEERS staff: for example, tell them ‘we are at the CAWs location: Alsip or General Use Waterway location: Crystal Lake today’. This will ensure everybody enters the correct location in survey A and B.
4. Offer CHEERS staff a copy of the recruiting script/FAQ sheet, if they want to brush up on what to say.
5. Offer the CHEERS staff job description documents, if they want to better understand their task for the day.
6. You can also brief the staff about any previous experiences at this location.
7. Assign tasks to CHEERS staff (you can rotate these assignments)
  - a. Recruiters- Each recruiter will have a clipboard with flyers, eligibility and refusal tally sheet. Recruiters will use eligibility and refusal tally sheet as and when they approach people. Participants must be able to return to finish Survey B before the CHEERS event for the day ends. They will then direct the participants to the CHEERS tent. **We do not need recruiters when we work with clubs/teams.**
  - b. DMs will consent participants and assign Case IDs. Please ensure all case IDs are in duplicate. **You will have rolls of Case IDs in your survey supplies. Please start from where the previous DM ended.** Read the instructions on how to consent.
  - c. DMs will record location, date of event, and participant progress by case IDs in the field data log book. Store signed consents in the black plastic file. Please count them on a regular basis.
  - d. DMs can direct the participants to the interviewers. You can also advice the interviewers as to whether the participant is a water or non-water recreator.
  - e. **Participants returning to complete Survey B must check-in with the DM first. If participant has lost/misplaced their wrist band- then find their consent form so that the correct Case ID can be used to finish the survey B.**
  - f. Interviewers- Each interviewer will have a laptop and scanner. Interviewers doing surveys must check with the participant if they are water recreators or non-water recreators before they start the surveys.
  - g. Interviewers will always open the CHEERS folder on the desktop. Followed by the “MAIN LAPTOP-X” folder. Please use “Part A.bat” file for survey A and “Part B.bat” file for survey B.
  - h. **Interviewers close out all interviews – answer all questions (including proxy question). If you enter the wrong case ID or start a wrong survey- then please leave a “Remark” before you start a new survey.**

**This is also the case when you lose power and start a survey on a new laptop. The remarks you leave helps the SRL staff reconcile the data for the phone surveys.**

- i. DM and Interviewers will check laptops batteries every 2 hours and swap batteries, if necessary. Place USED batteries in the USED/DEAD battery box.
- j. Incentive person- Please position yourself close to the DM. You can help the DM when he/she gets swamped. Always direct the participant to the DM when they return for their Survey B and incentives.
- k. Incentive person will always ask participants:
  - i. Have you completed both surveys today?
  - ii. Have you consented to donate incentives today?
- l. Incentive person will use the incentive sheets to record the date/location and start/end count of gift cards along with the participant's incentive status by case ID.
- m. Each participant will receive a t-shirt, gift card and stool flyer. Record "DONATE" if they donated incentives. **Please inform the DM if you run out of t-shirts or gift cards. You will need to record the participants cased ID, name and address so that we can mail it to them.**
- n. Monitor the CAWs use survey (see instructions for use survey).
- o. DM back-up the files onto the flash drive at the end of the shift. Copy the "**Main Laptop- X**" folder from each laptop.
- p. Complete CHEERS field report Note any problems in the field, including interviewer issues.
- q. Return all laptops, signed consents (in the black file), refusal tally sheets, and incentive sheets, time sheets, FLASH DRIVES WITH DATA, CAWs use survey and field report to the CHEERS supply manager/driver. The black log book can stay in the same box. Please count consents again.



### **For mobile recruiting:**

1. Organize the mobile folders-
  - a. Consents ( All adults 18+)
  - b. Assents +Parental Consents (All children between 8-17 years)
  - c. Parental Consents only (All children 0-7 years)
  - d. Location flyers
  - e. Case IDs
  - f. Laptop and scanner
  - g. Stapler
  
2. Clipboard-
  - a. Eligibility screener and Refusal Tally sheet
  - b. Mobile Log (just a sheet of paper)- to track Case IDs with survey A and B
  
3. What to do?
  - a. Approach people (make sure fishermen are yet to start fishing)
    - i. Recruit
    - ii. Eligibility screener
    - iii. Record in refusal tally if ineligible or refused to participate
  - b. If eligible to participate
    - i. Consent participant
    - ii. Give Case ID number- one on the wrist and one on the consent form. Make sure participant gets first 4 pages of consent form. Secure signed consent with ID in the folder.
    - iii. Record Case ID given out in a log (JUST A SHEET OF PAPER)
    - iv. Administer survey
      1. Non-water recreators get both survey A and B
      2. Water recreators will get only survey A and will be asked to return to the CHEERS tent for Survey B.
  - c. Incentives- please note that all participants will have to return to the CHEERS tent to collect their incentives. Make sure they check-in with the DM and then follow the same incentive procedures.
  - d. DM- You can send them out in groups of 2-3 (please monitor the process the first time). These are new interviewers and have minimal interview experience.
  - e. DM- Please review the consent process with all mobile interviewers.
  - f. DM- Make sure all interviewers return the log (sheet of paper) with case IDs given out and the corresponding consent forms.



# **QAPP 2**

## **Appendix 1M**

### **CHEERS Survey Training Manual**

#### **Mobile Recruiting Log**



# **QAPP 2**

## **Appendix 1N**

### **CHEERS Survey Training Manual**

#### **Recruiting Script**

**Training Material: Not for Distribution**

**CHEERS 2008 Field Recruiting Script**

Greeting: Good morning, good afternoon or good evening.....

I am (mention full name) from the University of Illinois Chicago (UIC) School of Public Health. We are conducting a research study. Have you heard about the CHEERS study?

OR

Greeting: Good morning, good afternoon or good evening.....

I am (mention full name) from the University of Illinois Chicago (UIC) School of Public Health. We are conducting a research study. If you have a few minutes we would like to tell you about the Chicago Health and Environment Exposure Research Study, also known as CHEERS.

OR

Greeting: Good morning, good afternoon or good evening.....

I am (mention full name) from the University of Illinois Chicago (UIC) School of Public Health. We are conducting a research study. Did someone hand you a CHEERS flyer (show participant a flyer)?

OR

Greeting: Good morning, good afternoon or good evening.....

I am (mention full name) from the University of Illinois Chicago (UIC) School of Public Health. (Hand out a flyer) We are conducting a research study. If you have a few minutes please stop by the CHEERS tent (point the direction or mention location)- we would like to tell you about the Chicago Health and Environment Exposure Research Study, also known as CHEERS.

OR

Greeting: Good morning, good afternoon or good evening.....

I am (mention full name) from the University of Illinois Chicago (UIC) School of Public Health. We are conducting a research study. CHEERS is an interesting research study for people who use various Chicago waterways for activities. You will receive a free t-shirt and \$50 for your participation in our study today.

# **QAPP 2**

## **Appendix 1-0**

### **CHEERS Survey Training Manual**

#### **Standard Ethics**

# **Standards and Ethics in Survey Research**

**CHEERS Survey Training  
Handout**

**2008 Season**



## STANDARDS AND ETHICS IN SURVEY RESEARCH

CHEERS is committed to the collection of high-quality, independent and unbiased data. We are also committed to following ethical principles and practices in the collection of these data. This commitment assures our clients, researchers, educators, business leaders, and policymakers that they can have confidence in the data we collect.

The material in this handout will help you to:

1. Understand the importance of ethical principles and practices in survey research.
2. Provide you with historical information related to the development of ethical practices in research.
3. Raise your awareness of the process of informed consent and the importance of confidentiality.
4. Help you understand your ethical responsibilities during the performance of your job as a data collector.
5. How to apply the training to field work.



## 1) What is at the core of ethical principles and practices in survey research?

At the core of ethics in data collection is that researchers have responsibilities to the public, to their clients, to study participants, and to you—data collectors.

- Researchers have a responsibility to the public to ensure that the survey findings released/published are an accurate portrayal of survey data. This includes conducting mandatory checks on the accuracy of the information collected.
- Researchers have a responsibility to clients to conduct work as agreed upon (in their contracts) and to maintain all proprietary information in a confidential manner.
- Researchers have a responsibility to study participants (1) to inform them about the basic elements of participation; (2) to maintain participant data confidentiality; and (3) to avoid using practices or methods that may harm, humiliate, or seriously mislead participants.
- Researchers have a responsibility to you—data collectors. Researchers cannot ask you to engage in any activity during the performance of your job as a data collector that does not follow the general principles specified above with regard to the public, our clients, and study participants.

## 2) What are the key international and national events surrounding the development of standards and ethics in research?

Following World War II, the allies convened the Nuremberg Court to try Nazi war criminals and expose Nazi medical war crimes. These crimes included medical testing on unsuspecting human subjects.

In 1949, the court published the **Nuremberg Code** that:

- Formed the basis of global ethics codes for medical researchers.
- Emphasized the importance of voluntary consent for research participants.
- Stated that risks to research participants should be minimized.
- Stressed that participants must be allowed to withdraw from research.

During the years following the publication of the Nuremberg Code, the World Medical Association continued to work on ethics in research, and in 1964 they issued a landmark document called the **Declaration of Helsinki**. This document expanded on the principles laid out in the Nuremberg Code and, most importantly, made “informed consent” a requirement for medical research. It stipulated that study participants must “formally” consent to participation in a study after being fully informed about the basic elements of the study.

At the same time, ethical problems were being uncovered in medical experiments and testing in U.S. research.

Three of the most famous or infamous examples of a lack of oversight were the:

- Tuskegee Alabama Syphilis Study.
- Jewish Chronic Disease Hospital Study.
- Willowbrook Study.

The **Tuskegee Alabama Syphilis Study** tracked the progression of syphilis in African American males. Study researchers “knowingly” did not treat study participants who had syphilis with penicillin even though it was known to be an effective treatment for syphilis.

In the **Jewish Chronic Disease Hospital Study** of 1963, live cancer cells were injected into chronically ill patients without informed consent. The researchers believed that the cancer cells would be rejected. They rationalized their actions by stating that they didn’t want to “alarm” the patients.

The **Willowbrook Study** ran from 1963 through 1966. In this study, live hepatitis was injected into children labeled mentally impaired. The researchers rationalized that the majority of the children would have acquired the infection in the future anyway. In this study, the parents of the children did give consent.

These and other studies raised important questions about ethical practices in our country. The result was that, beginning in 1966, Congress and Federal agencies implemented legislation and developed regulations to protect human subjects—also referred to as study participants.

In **1966**, the U.S. Surgeon General and the head of the National Institutes of Health (NIH) decreed that to conduct research sponsored or subsidized by the Federal Government, researchers would have to submit their research plans for prior review and approval to an independent committee. Today these committees are called **Institutional Review Boards or IRBs**. All Westat studies dealing with human subjects must be reviewed and approved by Westat and client IRBs.

In **1974**, Congress passed the **Privacy Act**. This act focused on restricting the disclosure of personally identifiable records by establishing a code of “fair information practices” to protect study participants.

In **1979**, the Federal Government published the **Belmont Report**, which is considered to be the foundation of ethical research in the United States. It stipulates that study participants must be treated with respect, with beneficence (i.e., protection of participant well-being), and with justice (i.e., in a fair manner).

In **1981**, the **Code of Federal Regulation of Research with Human Subjects** was issued and a Federal office to monitor and support the code was established. By 1991 17 Federal departments and agencies had adopted these regulations—often referred to as the “**Common Rule**.”

In **1995**, another important piece of legislation was passed—the **Paper Work Reduction Act**. It mandated that each Federal agency must review the collection of information in terms of its need, the burden on the respondent, and the plans for using the information collected. It also reinforced the informed consent process and stipulated that authorized studies cannot be fielded or implemented without a valid control number assigned by the Office of Management and Budget displayed on printed material.

### 3) **What is informed consent?**

**Informed consent** is a process where the researchers explain both the risks and the benefits of the research study to the potential human subjects and obtain the subject's permission/consent, whether verbal or written, for them to participate in the study.

Participants must agree or consent to take part in a study before the start of their participation. Their agreement or consent to participate must be an informed one. “Informed participants” are those knowledgeable about the basic elements of study participation.

**3a) What are the basic elements of informed consent that participants must know?**

Study participants must:

- Know who the sponsor is and what the purpose and duration of the research are.
- Understand the procedures of the study—the tasks they will be asked to participate in.
- Know that their participation is voluntary.
- Understand the expected risks and benefits of participating in the study.
- Know if and what compensation exists.
- Know that the information they provide will be maintained following the rules and laws pertaining to confidentiality.
- Understand that they can withdraw from the study at any time.
- Know who to contact if they have questions.

Every study has an informed consent process. The process can vary.

At a minimum, the study must include a **verbal introduction** which specifies all of the basic elements of informed consent we just reviewed. Some studies have **prepared materials** such as advance letters and brochures that must be given to the participant and again include the basic elements of informed consent.

Other studies have an actual **consent form** that must be read and signed by the participant. Studies can have some or all of the above procedures. Data collectors must follow the informed consent procedures of the study they are working on “to the letter.”

**3b) What is confidentiality?**

Confidentiality involves:

- The appropriate treatment of information disclosed in a relationship of trust.
- Meeting the expectation that such information will not be disclosed to others without permission.

Confidentiality includes information collected during an interview and information gleaned from observation, such as observations of the interview setting, the condition of a respondent's home, interpersonal communications observed among family members, etc.

**3c) Why is confidentiality important to survey participants?**

Survey participants must be assured:

- That information provided in confidence will not be used outside the stated purposes of the study.
- That they cannot be uniquely identified based on any study information distributed for public and/or private use.

**3d) Why is confidentiality important to CHEERS?**

- CHEERS staff are ethically bound to follow the confidentiality requirements set forth by our UIC IRB.
- A major breach in data confidentiality procedures could affect our ability to obtain contracts and/or gain respondent cooperation in the future.

**3e) Who must maintain study data confidentiality?**

All project staff must maintain study data confidentiality. This includes:

- CHEERS interviewers

- CHEERS water staff
- CHEERS home visit staff
- CHEERS consultants and subcontractors
- Field supervisors and data collectors
- Field translators, interpreters, and escorts (if used)
- Study Director, Assistant Directors, Coordinators, etc.

**3f) What are your responsibilities with regard to confidentiality?**

- You are the front line of the data collection process—data confidentiality in the field begins with you.
- You cannot disclose anything learned during data collection to anyone except project team members or supervisors.
- You cannot discuss information collected or observed with anyone outside the project staff (i.e., other data collectors not on the project, family members, or friends).
- Unless a special exception is made by project managers, you should not interview anyone you know.
- All data you collect must be submitted through secure electronic transmission and/or other hard-copy submission procedures established for the project.

**4) CHEERS Data Security**

CHEERS has established a quality assurance plan to ensure data security confidentiality. Our plan is based on the following principles:

- Study data must be protected from unauthorized access;
- Every step of data collection, from design to data release and distribution, must be reviewed.

- Study protocols for maintaining confidentiality and data security must be based on documented and proven procedures. This is outlined in the Quality Assurance Protocol.
- All project staff, even volunteer staff and/or short-term staff (e.g., interpreters, escorts), must make every effort to protect data and ensure quality.
- All project staff must be trained to follow the quality assurance plan and maintain confidentiality.

The quality assurance plan is implemented when the study design phase begins and ends with the release of the data to the public.

The key elements of the security plan are:

- Substituting participant codes for participant identifiers (e.g., using an ID# versus the name of participant).
- Separating participant identifiers from survey data. For example, a list with participant name, phone number, and case ID must be destroyed after use or handed over to a supervisor.
- Limiting access to identifiable data.
- Minimizing hard-copy materials kept.
- Storing paper records and materials with identifiers in a secure place in offices, homes, hotel rooms, cars, airplanes, etc.—any place where the records may be at a given point in the data collection process.
- Shredding “unneeded” survey documents with identifiers ASAP.
- Providing security codes (user IDs and passwords) for computerized records.
- Training staff to keep laptops secure in participant homes, offices, hotel rooms, cars, airports, etc.
- When necessary, emailing only data “without” identifiers via the Internet. Or sharing password protected files.
- Storing study data on secure network drives.
- Restricting access to network directories.



- Avoiding the production of analysis files and reports with small cells (e.g., single, female, Ph.D. statistician in small fishing village in Maine).
- Including respondent identification information only as necessary in analysis files and reports.
- Avoiding the production of public-release files with identifying information and data that can be matched against publicly available databases.

The CHEERS study expects data collectors, to follow during their employment on a project, all codes from ethics, to technical performance, to work style, and confidentiality.

#### **5) What to do while conducting interviews.**

- Make sure that you ask the potential respondent if they want to participate in the survey or study. Wait for a verbal yes or no.
- Give the potential respondent time to make a decision.
- If they respond with a verbal “yes” provide the participant with the informational pamphlet/consent form.
- Children under 7 are allowed to participate in this study with the signed consent of the legal guardian, but no assent is needed from the child. Children 8 to 17 years are allowed to participate in the study with the signed consent of the legal guardian and a signed assent from the child. Anyone 18 and older requires only eligibility and a signed consent to participate.
- Approach all potential respondents with respect. Do not argue with the participant. If the potential respondent is rude to you, thank him or her for his or her time and terminate the interview.
- Answer all participants basic questions with knowledge provided to you during training. However, for extended or hard to answer questions, refer him or her to the CHEERS supervisor on site.
- If an individual appears incompetent to participate, do not ask them to participate. Thank him or her for his or her time and walk away.
- State, “No physical risks are involved in participating in this survey.”

- You must inform all possible respondents of the incentives: CHEERS t-shirt, \$15 Target gift card and \$35 for completing the telephone interviews. Do not bribe potential respondents. Simply inform them of the incentives and the benefits of participating in the study, and always thank them for their time, even if they choose not to participate.
- Approach all groups of potential respondents fairly. Do not exclude respondents based on sex, race, ethnicity, language, physical disability, or age.
  - Exceptions are persons under the age of 18 and persons that appear incompetent to make the decision to participate and answer questions.
  - We will have bilingual interviewers that speak Spanish. Always attempt to conduct the interview in English. If the potential participant needs the interview conducted in Spanish, request one of the bilingual interviewers to conduct the interview in Spanish. If the respondent understands or speaks another language besides Spanish and English, we will have to exclude the respondent from the study. Code the as ineligible.
- Do not discuss the respondents' answers with anyone. In the extreme instance that a surveyor must discuss a participant's responses, do so only with individuals associated with the survey and make certain not to identify the respondent. These discussions should normally be between the interviewer and a field supervisor or field manager or data manager on site.
- Do not take **ANY** questionnaires home. Edit all questionnaires at the field location. Questionnaires will always be monitored by supervisory personnel except during the times when they are secured in a locked receptacle.

# **QAPP 2**

## **Appendix 1P**

### **CHEERS Survey Training Manual**

#### **Water Quality Flier**

## Water Quality Information for the Public



IRB approval box

STARTS **APPROVAL** EXPIRES

JUN 21 2008 JUN 20 2009

UNIVERSITY OF ILLINOIS AT CHICAGO  
INSTITUTIONAL REVIEW BOARD

### The Chicago River and Calumet River system

These river systems are managed by the Metropolitan Water Reclamation District of Greater Chicago. Swimming, jet skiing and water skiing not allowed in these waterways, but activities such as boating, fishing, and rowing are allowed. For more information about the waterways, visit: <http://www.chicagoareawaterways.org/>

For more information about the Metropolitan Water Reclamation District, visit:  
<http://www.mwrldg.dst.il.us/>

### Lakes and Beaches

For more information about beach health and beach closings in Chicago, please visit the website of the Chicago Park District Beach Report  
[http://chicagoparkdistrict.com/index.cfm/fuseaction/index.cfm/fuseaction/swim\\_report.home](http://chicagoparkdistrict.com/index.cfm/fuseaction/index.cfm/fuseaction/swim_report.home)

For more information about beach health, please visit to website of the Illinois Department of Public Health Beach Information  
<http://www.idph.state.il.us/envhealth/beachhome.htm>

For more information about water quality on Lake Michigan, visit the website of the Alliance for the Great Lakes: <http://www.greatlakes.org/>

### Eating fish caught in Illinois rivers and lakes

General information, 2007:

<http://www.jchdonline.org/jackson/Fish%20Advisory%2002.02.07.pdf>

Great lakes fish: <http://www.great-lakes.net/envt/flora-fauna/wildlife/fishadv.html>

The Chicago River system: <http://www.idph.state.il.us/envhealth/fishadv/chicagoriver.htm>

## **QAPP 2**

### **Appendix 2**

## **NEEAR Study Beach Survey**

# Study for Beaches Program

2007

## Beach Interview

Part A  
1/26/2007

**Interview status (circle one)**

Complete (Part A & B)

Refused

Ineligible

Incomplete

Leaving Late (after 6pm)

**Language (circle if in Spanish)**

Given in Spanish

**Gift received (circle one):**

COOLER      TOTE BAG

U.S. Environmental Protection Agency  
Research Triangle Park, North Carolina 27711

Centers For Disease Control and Prevention  
1600 Clifton Rd  
Atlanta, GA 30333

Westat, Inc.  
1650 Research Boulevard  
Rockville, Maryland 20850-3195

OMB: 2080.0068

Part A data verified (sign) \_\_\_\_\_

Expires: 09/30/2008

Part B data verified (sign) \_\_\_\_\_

Questionnaire #:   \_\_  \_\_  \_\_

## BEACH INTERVIEW

Interviewer Name (Part A): .....  
Last First

Site ID: .....

Saturday: \_\_\_\_\_ Sunday: \_\_\_\_\_ Monday: \_\_\_\_\_ Friday: \_\_\_\_\_

Date: \_\_\_\_ / \_\_\_\_ / \_\_\_\_

Time: .....AM PM (circle one)

X1. Latitude: \_\_\_\_\_

X2. Longitude: \_\_\_\_\_

X3. Transect Area: \_\_\_\_\_

---

Hi, my name is \_\_\_\_\_. I am conducting the *National Beaches Survey*.

Q1. Have you been interviewed by the National Beaches Survey in the last 28 (4weeks) days?

YES..... 1 → **TERMINATE INTERVIEW**  
NO..... 2

Q1a. **INTERVIEWER BY OBSERVATION: IS THE RESPONDENT 18 OR OLDER?**

YES..... 1  
NO..... 2

Here is a pamphlet describing the study. **(GIVE RESPONDENT THE CONSENT TRI-FOLD PAMPHLET)**

**INTERVIEWER:** The federal government is conducting a nationwide research study on the health of swimmers at marine and Great Lakes beaches. The Environmental Protection Agency (EPA) and the Centers for Disease Control and Prevention (CDC) are the two agencies that are supporting the study. The study involves a two-part questionnaire that you complete today and a telephone interview 10-12 days from now. Your participation today will greatly assist the government in developing better guidelines for safe beach water quality and may improve beachgoer's health. Your participation is voluntary and you may stop the interview at any time. There are no risks involved from participating in this survey. It will take about 10 to 15 minutes of your time for these beach questions and about the same time for an exit interview at the bath house. At the bathhouse we have a gift for you, when you leave to go home. After completing the beach and telephone interview, you will also receive a check for the total of \$25. Your responses to the questions will be confidential and your address and other contact information will be destroyed after you complete the telephone interview and we send you your *Thank You* check.

Q2. May we continue?

YES..... 1 → **START INTERVIEW**  
NO..... 2 → **REFUSAL, GO TO 5.a.**

**INTERVIEWER:** Collect GPS coordinates for participants and nonparticipants.

Q2a. Our survey is primarily for households of one or more persons that live together at the same address. Do you all live at the same address? **(INTERVIEWER PROBE TO IDENTIFY HOUSEHOLD. IF MORE THAN ONE HOUSEHOLD WITH A DIFFERENT ADDRESS, INTERVIEW EACH SEPARATELY.)**

YES ..... 1  
NO ..... 2

Q3. How many members in your household are at the beach today including yourself?

\_\_\_\_\_ MEMBERS

**For the rest of this interview, I will be asking questions mostly about those people in your household who are here today at the beach.**

Q4. What time did you and your household arrive at the beach today? **(CIRCLE AM OR PM)**

\_\_\_\_\_ AM PM

Q5. We are interested in asking about the health of your household during the few weeks following your beach visit. Could you please give me your telephone number so we can get in touch with you in 10-12 days from now?

YES ..... 1 → **GO TO Q5B**  
NO ..... 2 → **GO TO Q5A**

Q5a. **IF “NO,”** Is it for one of the following reasons?

Too busy ..... 1  
No longer interested ..... 2  
Will not be available ..... 3  
Other reason? ..... 4  
Please specify: .....

**INTERVIEWER:** Collect GPS Coordinates all persons on beach regardless of participation.

**INTERVIEWER:** We will end the interview here since a contact telephone number is required to complete the telephone interview that I mentioned. Thank you for speaking with us.

Q5b. 10-12 days from now which phone number(s) should we call?

\_\_\_\_\_

Q5c. Is this your home, vacation, or cell phone number?

Home Phone ..... 1  
Vacation Phone..... 2  
Cell Phone ..... 3  
Specify other ..... 4



Q6. What are the best times to reach you during week days?  
**(INTERVIEWER: MARK WITH AN "X" ALL DAYS THAT APPLY AND APPROXIMATE TIME SPAN.)**

		Mon.	Tues.	Wed.	Thurs.	Fri.
Morning	8:00 AM-12:00 PM (Noon)					
Afternoon	12:01 PM-5:00 PM					
Evening	5:00 PM-9:00 PM					

**INTERVIEWER:** We'll try to reach you during that (those) time(s).

Q6a. Can I please have your mailing address so that we can send you your \$25 *Thank You* check?

First Name: \_\_\_\_\_ Last Name \_\_\_\_\_

Address: .....

City: ..... State: ..... Zip: .....

**INTERVIEWER:** We will destroy your identifying information after we mail the check.

Q7. Please tell me the first name of the members of your household at the beach today, their birth dates, gender, race, ethnicity, and whether they are in diapers.

**[INTERVIEWER: IF 8 OR MORE PEOPLE, USE SUPPLEMENTAL QUESTIONNAIRES.]**

	First Name	Date of Birth	Gender	Hispanic	Race*	In Diapers
You		___/___/___ RF DK	M F RF DK	Y N RF DK		Y N RF DK
Person 2		___/___/___ RF DK	M F RF DK	Y N RF DK		Y N RF DK
Person 3		___/___/___ RF DK	M F RF DK	Y N RF DK		Y N RF DK
Person 4		___/___/___ RF DK	M F RF DK	Y N RF DK		Y N RF DK
Person 5		___/___/___ RF DK	M F RF DK	Y N RF DK		Y N RF DK
Person 6		___/___/___ RF DK	M F RF DK	Y N RF DK		Y N RF DK
Person 7		___/___/___ RF DK	M F RF DK	Y N RF DK		Y N RF DK
Person 8		___/___/___ RF DK	M F RF DK	Y N RF DK		Y N RF DK

\*Race:

- |                                     |  |
|-------------------------------------|--|
| 1. White                            | 5. Native Hawaiian or Other Pacific Islander |
| 2. Black or African American        | 6. Other                                     |
| 3. Asian                            | 7. Refused                                   |
| 4. American Indian or Alaska Native | 8. Don't Know                                |

Q8. Will (you/all these people at the beach with you today) be living (with you) at the same address(es) during the next two weeks?

**YES NO RF DK**

Person 1..... 1 .....2 .....7 ..... 8  
 Person 2..... 1 .....2 .....7 ..... 8  
 Person 3..... 1 .....2 .....7 ..... 8  
 Person 4..... 1 .....2 .....7 ..... 8  
 Person 5..... 1 .....2 .....7 ..... 8  
 Person 6..... 1 .....2 .....7 ..... 8  
 Person 7..... 1 .....2 .....7 ..... 8  
 Person 8..... 1 .....2 .....7 ..... 8

Q9. Have any of these household members at the beach today been ill in the past 3 days with . . .

Person	1	2	3	4	5	6	7	8
	Y N RF DK	Y N RF DK	Y N RF DK	Y N RF DK	Y N RF DK	Y N RF DK	Y N RF DK	Y N RF DK
a. Diarrhea or loose bowels? .....	1 2 7 8	1 2 7 8	1 2 7 8	1 2 7 8	1 2 7 8	1 2 7 8	1 2 7 8	1 2 7 8
b. Urinary tract infection or .....	1 2 7 8	1 2 7 8	1 2 7 8	1 2 7 8	1 2 7 8	1 2 7 8	1 2 7 8	1 2 7 8
c. Throwing up or vomiting? .....	1 2 7 8	1 2 7 8	1 2 7 8	1 2 7 8	1 2 7 8	1 2 7 8	1 2 7 8	1 2 7 8
d. Sore throat or cough? .....	1 2 7 8	1 2 7 8	1 2 7 8	1 2 7 8	1 2 7 8	1 2 7 8	1 2 7 8	1 2 7 8
e. Earache, ear infection or runny .....	1 2 7 8	1 2 7 8	1 2 7 8	1 2 7 8	1 2 7 8	1 2 7 8	1 2 7 8	1 2 7 8
f. Eye infection? .....	1 2 7 8	1 2 7 8	1 2 7 8	1 2 7 8	1 2 7 8	1 2 7 8	1 2 7 8	1 2 7 8
g. Rash or itchy skin? ....	1 2 7 8	1 2 7 8	1 2 7 8	1 2 7 8	1 2 7 8	1 2 7 8	1 2 7 8	1 2 7 8
h. Sunburn? .....	1 2 7 8	1 2 7 8	1 2 7 8	1 2 7 8	1 2 7 8	1 2 7 8	1 2 7 8	1 2 7 8

Q10. Are there any household members **not** present at the beach today?

YES..... 1 → **GO TO Q10a**  
 NO..... 2 → **GO TO Q11**  
 REFUSED..... 7 → **GO TO Q11**  
 DON'T KNOW..... 8 → **GO TO Q11**

Q10a. Have any household members **not** present at the beach today been ill in the past 3 days with . . .

	Y N RF DK
a. Diarrhea or loose bowels?.....	1 2 7 8
b. Urinary tract infection or burning sensation when urinating? .....	1 2 7 8
c. Throwing up or vomiting? .....	1 2 7 8
d. Sore throat or cough?.....	1 2 7 8
e. Earache, ear infection or runny ears? ...	1 2 7 8
f. Eye infection? .....	1 2 7 8
g. Rash or itchy skin? .....	1 2 7 8

Q11. Do you or any household members at the beach today, not including any one that stayed at home, suffer from any of the following chronic, long-term conditions?

Person	1	2	3	4	5	6	7	8
	Y N RF DK	Y N RF DK	Y N RF DK	Y N RF DK	Y N RF DK	Y N RF DK	Y N RF DK	Y N RF DK
a. Gastrointestinal problems such as Crohn's disease or irritable bowel syndrome .....	1 2 7 8	1 2 7 8	1 2 7 8	1 2 7 8	1 2 7 8	1 2 7 8	1 2 7 8	1 2 7 8
b. Chronic respiratory diseases such as asthma or emphysema....	1 2 7 8	1 2 7 8	1 2 7 8	1 2 7 8	1 2 7 8	1 2 7 8	1 2 7 8	1 2 7 8
c. Allergies, other than drug allergies	1 2 7 8	1 2 7 8	1 2 7 8	1 2 7 8	1 2 7 8	1 2 7 8	1 2 7 8	1 2 7 8
d. Skin problems such as psoriasis or eczema .....	1 2 7 8	1 2 7 8	1 2 7 8	1 2 7 8	1 2 7 8	1 2 7 8	1 2 7 8	1 2 7 8

Q12. How many times do you usually come to this beach each year?

..... TIMES

REFUSED..... 7

DON'T KNOW..... 8

Q13. How many miles did you travel to the beach today?

..... MILES

REFUSED..... 7

DON'T KNOW..... 8

Q14. During the past two weeks, did you (anyone in your household at the beach today) go bathing or swimming anywhere - at this or some other beach, pool or lake?

	YES	NO	RF	DK
Person 1.....	1.....	2.....	7.....	8.....
Person 2.....	1.....	2.....	7.....	8.....
Person 3.....	1.....	2.....	7.....	8.....
Person 4.....	1.....	2.....	7.....	8.....
Person 5.....	1.....	2.....	7.....	8.....
Person 6.....	1.....	2.....	7.....	8.....
Person 7.....	1.....	2.....	7.....	8.....
Person 8.....	1.....	2.....	7.....	8.....

**IF NO TO PERSON 1 THROUGH PERSON 8, GO 14c**

Q14a. Did you {PERSON} go bathing or swimming anywhere in the past one week (Monday through Friday) at this or some other beach, pool or lake ?

	YES	NO	RF	DK
Person 1.....	1.....	2.....	7.....	8
Person 2.....	1.....	2.....	7.....	8
Person 3.....	1.....	2.....	7.....	8
Person 4.....	1.....	2.....	7.....	8
Person 5.....	1.....	2.....	7.....	8
Person 6.....	1.....	2.....	7.....	8
Person 7.....	1.....	2.....	7.....	8
Person 8.....	1.....	2.....	7.....	8

Q14b. Did you {PERSON} actually get their head or face wet?

	YES	NO	RF	DK
Person 1.....	1.....	2.....	7.....	8
Person 2.....	1.....	2.....	7.....	8
Person 3.....	1.....	2.....	7.....	8
Person 4.....	1.....	2.....	7.....	8
Person 5.....	1.....	2.....	7.....	8
Person 6.....	1.....	2.....	7.....	8
Person 7.....	1.....	2.....	7.....	8
Person 8.....	1.....	2.....	7.....	8

Q14c. During the past 2 weeks, did you (person) get a sunburn that lasted more than 12 hours?

	YES	NO	RF	DK
Person 1.....	1.....	2.....	7.....	8
Person 2.....	1.....	2.....	7.....	8
Person 3.....	1.....	2.....	7.....	8
Person 4.....	1.....	2.....	7.....	8
Person 5.....	1.....	2.....	7.....	8
Person 6.....	1.....	2.....	7.....	8
Person 7.....	1.....	2.....	7.....	8
Person 8.....	1.....	2.....	7.....	8

**ENTER HERE IF NO TO Q14**

**INTERVIEWER: DID YOU RECORD THE LONGITUDE AND LATITUDE COORDINATES ON PAGE 1?**

**THE FOLLOWING IS ENTERED BY THE INTERVIEWER:**

**X4. HOW COOPERATIVE WAS THIS HOUSEHOLD?**

Very.....	1
Somewhat.....	2
Not at all.....	3

**X5. WAS INTERVIEW CONDUCTED IN SPANISH?**

YES.....	1
NO.....	2

**INTERVIEWER: END OF PART A. PLEASE RETURN QUESTIONNAIRE TO THE BATH HOUSE.**

**End A:** Please go to the exit stations when you leave the beach today, before 5:30 PM, to complete Part B of the Beach Interview and to pick-up your beach gift. Thank you for participating in this portion of the survey.

Interviewer Part A: \_\_\_\_\_

Date: \_\_\_ / \_\_\_ / \_\_\_

Questionnaire #: \_\_\_\_\_

Interviewer Part B: \_\_\_\_\_

### Part B Beach Survey

Thank you for returning to complete the beach interview. We will have your gift ready for you after we complete the interview. Some of the questions will be repetitive to ensure accuracy. May we have your name to link it to your previous answers?

Q15. Were you the person that we interviewed on the beach or earlier today?

- YES..... 1
- NO..... 2

**Q15a. INTERVIEWER: IF NO, CHECK Q7 TO DETERMINE THE PERSON YOU ARE INTERVIEWING.**

Person \_\_\_\_\_

Q16. Did you or anyone in your household wade, swim, or play in the water today? **Name Droplist**

	YES	NO	RF	DK
Person 1.....	1.....	2.....	7.....	8
Person 2.....	1.....	2.....	7.....	8
Person 3.....	1.....	2.....	7.....	8
Person 4.....	1.....	2.....	7.....	8
Person 5.....	1.....	2.....	7.....	8
Person 6.....	1.....	2.....	7.....	8
Person 7.....	1.....	2.....	7.....	8
Person 8.....	1.....	2.....	7.....	8

**IF NO TO PERSON 1 THROUGH PERSON 8, GO TO Q17**

Person	1	2	3	4	5	6	7	8
	Y N R F DK	Y N R F DK	Y N R F DK	Y N R F DK	Y N R F DK	Y N R F DK	Y N R F DK	Y N R F DK
Q16a.1. Did {PERSON} immerse their body, not necessarily {PERSON's} head, in water today?.....	1 2 7 8	1 2 7 8	1 2 7 8	1 2 7 8	1 2 7 8	1 2 7 8	1 2 7 8	1 2 7 8
Q16a.2. Did {PERSON} put their face in water or submerge head in water today? .....	1 2 7 8	1 2 7 8	1 2 7 8	1 2 7 8	1 2 7 8	1 2 7 8	1 2 7 8	1 2 7 8
Q16a.3. Did {Person} get water in the mouth today?	1 2 7 8	1 2 7 8	1 2 7 8	1 2 7 8	1 2 7 8	1 2 7 8	1 2 7 8	1 2 7 8

**IF NO TO PERSON 1 THROUGH PERSON 8 FOR THE ABOVE QUESTION, Q16a.3, GO TO Q16b.**

Q16.a. Did {PERSON} swallow the water?

	YES	NO	RF	DK
Person 1.....	1.....	2.....	7.....	8.....
Person 2.....	1.....	2.....	7.....	8.....
Person 3.....	1.....	2.....	7.....	8.....
Person 4.....	1.....	2.....	7.....	8.....
Person 5.....	1.....	2.....	7.....	8.....
Person 6.....	1.....	2.....	7.....	8.....
Person 7.....	1.....	2.....	7.....	8.....
Person 8.....	1.....	2.....	7.....	8.....

[PROGRAMMER NOTE: PUT IN POP UP ASSIST TO SHOW TIME OF QUESTION 4.]

Q16b. Was {PERSON} in the water at the following times today? **READ ONLY FOR TIME PERIODS THEY WERE AT THE BEACH BASED ON THE ANSWER FROM Q4 ABOVE.** If "Yes," what part of the beach did {PERSON} swim in? **INDICATE AREA ON THE MAP.**

[PROGRAMMER NOTE: PREASSIGNED AREA DESIGNATIONS FOR EACH BEACH.]

Person	1	2	3	4	5	6	7	8
Times	Y N	Y N	Y N	Y N	Y N	Y N	Y N	Y N
Before 10:00 am	1 2	1 2	1 2	1 2	1 2	1 2	1 2	1 2
10:00 AM -11:59 AM	1 2	1 2	1 2	1 2	1 2	1 2	1 2	1 2
12:00 PM - 1:59 PM	1 2	1 2	1 2	1 2	1 2	1 2	1 2	1 2
2:00 PM - 3:59 PM	1 2	1 2	1 2	1 2	1 2	1 2	1 2	1 2
4:00 PM - 5:30 PM	1 2	1 2	1 2	1 2	1 2	1 2	1 2	1 2
Area								
	RF DK	RF DK	RF DK	RF DK	RF DK	RF DK	RF DK	RF DK

**INTERVIEWER: MARK AREA WHERE PERSON SWAM MOST OF THE TIME.**

Q16c. What total time did {PERSON} stay in the water? We are only interested in time actually in the water, not the total time at the beach. **(CIRCLE TIME UNITS)**

			RF	DK
Person 1 .....	___ MINUTES	___ HOURS	7	8
Person 2 .....	___ MINUTES	___ HOURS	7	8
Person 3 .....	___ MINUTES	___ HOURS	7	8
Person 4 .....	___ MINUTES	___ HOURS	7	8
Person 5 .....	___ MINUTES	___ HOURS	7	8
Person 6 .....	___ MINUTES	___ HOURS	7	8
Person 7 .....	___ MINUTES	___ HOURS	7	8
Person 8 .....	___ MINUTES	___ HOURS	7	8

Q16d. Did {PERSON} engage in any of the following water-related activities while at the beach today?  
**(Circle all that apply)**

Person	1	2	3	4	5	6	7	8
	Y N RF DK	Y N RF DK	Y N RF DK	Y N RF DK	Y N RF DK	Y N RF DK	Y N RF DK	Y N RF DK
Swimming	1 2 7 8	1 2 7 8	1 2 7 8	1 2 7 8	1 2 7 8	1 2 7 8	1 2 7 8	1 2 7 8
Swimming laps	1 2 7 8	1 2 7 8	1 2 7 8	1 2 7 8	1 2 7 8	1 2 7 8	1 2 7 8	1 2 7 8
Surfing	1 2 7 8	1 2 7 8	1 2 7 8	1 2 7 8	1 2 7 8	1 2 7 8	1 2 7 8	1 2 7 8
Body Surfing	1 2 7 8	1 2 7 8	1 2 7 8	1 2 7 8	1 2 7 8	1 2 7 8	1 2 7 8	1 2 7 8
Kite Surfing	1 2 7 8	1 2 7 8	1 2 7 8	1 2 7 8	1 2 7 8	1 2 7 8	1 2 7 8	1 2 7 8
Wind Surfing	1 2 7 8	1 2 7 8	1 2 7 8	1 2 7 8	1 2 7 8	1 2 7 8	1 2 7 8	1 2 7 8
Sailing (Hobie cat, Sunfish, etc)	1 2 7 8	1 2 7 8	1 2 7 8	1 2 7 8	1 2 7 8	1 2 7 8	1 2 7 8	1 2 7 8
Paddle Boating	1 2 7 8	1 2 7 8	1 2 7 8	1 2 7 8	1 2 7 8	1 2 7 8	1 2 7 8	1 2 7 8
Canoeing or Kayaking	1 2 7 8	1 2 7 8	1 2 7 8	1 2 7 8	1 2 7 8	1 2 7 8	1 2 7 8	1 2 7 8
Rafting	1 2 7 8	1 2 7 8	1 2 7 8	1 2 7 8	1 2 7 8	1 2 7 8	1 2 7 8	1 2 7 8
Floating on an air mattress	1 2 7 8	1 2 7 8	1 2 7 8	1 2 7 8	1 2 7 8	1 2 7 8	1 2 7 8	1 2 7 8
Snorkeling	1 2 7 8	1 2 7 8	1 2 7 8	1 2 7 8	1 2 7 8	1 2 7 8	1 2 7 8	1 2 7 8
Scuba Diving	1 2 7 8	1 2 7 8	1 2 7 8	1 2 7 8	1 2 7 8	1 2 7 8	1 2 7 8	1 2 7 8
Jet Skiing	1 2 7 8	1 2 7 8	1 2 7 8	1 2 7 8	1 2 7 8	1 2 7 8	1 2 7 8	1 2 7 8
Water Skiing	1 2 7 8	1 2 7 8	1 2 7 8	1 2 7 8	1 2 7 8	1 2 7 8	1 2 7 8	1 2 7 8
Placemaker for sport	1 2 7 8	1 2 7 8	1 2 7 8	1 2 7 8	1 2 7 8	1 2 7 8	1 2 7 8	1 2 7 8
Placemaker for sport	1 2 7 8	1 2 7 8	1 2 7 8	1 2 7 8	1 2 7 8	1 2 7 8	1 2 7 8	1 2 7 8
Did {person} have contact with water in a non-circulating pool or tidal pool?	1 2 7 8	1 2 7 8	1 2 7 8	1 2 7 8	1 2 7 8	1 2 7 8	1 2 7 8	1 2 7 8

**INTERVIEWER:** We would like to ask a few questions about things that may help protect swimmers from becoming ill.

Q17. What would {PERSON} estimate (your/his/her) total time in direct sunlight was? This does not include being indoors or under umbrellas, etc. **(CIRCLE TIME UNITS)** Explain to participant that cloudy day is not considered

			RF	DK
Person 1	.....	MINUTES	7	8
Person 2	.....	MINUTES	7	8
Person 3	.....	MINUTES	7	8
Person 4	.....	MINUTES	7	8
Person 5	.....	MINUTES	7	8
Person 6	.....	MINUTES	7	8
Person 7	.....	MINUTES	7	8
Person 8	.....	MINUTES	7	8



Q18. Did {PERSON} engage in any of the following activities while at the beach today?

Person	1	2	3	4	5	6	7	8
	Y N RF DK	Y N RF DK	Y N RF DK	Y N RF DK	Y N RF DK	Y N RF DK	Y N RF DK	Y N RF DK
<b>a.</b> collecting sea shells, rocks, feathers, etc? .....	1 2 7 8	1 2 7 8	1 2 7 8	1 2 7 8	1 2 7 8	1 2 7 8	1 2 7 8	1 2 7 8
<b>b.</b> digging in sand or building sand castles.	1 2 7 8	1 2 7 8	1 2 7 8	1 2 7 8	1 2 7 8	1 2 7 8	1 2 7 8	1 2 7 8
<b>c.</b> had their body buried in sand .....	1 2 7 8	1 2 7 8	1 2 7 8	1 2 7 8	1 2 7 8	1 2 7 8	1 2 7 8	1 2 7 8
<b>c.1.</b> Did {person} get any sand in their mouth?	1 2 7 8	1 2 7 8	1 2 7 8	1 2 7 8	1 2 7 8	1 2 7 8	1 2 7 8	1 2 7 8
<b>IF YES TO b or c</b>	1 2 7 8	1 2 7 8	1 2 7 8	1 2 7 8	1 2 7 8	1 2 7 8	1 2 7 8	1 2 7 8
<b>c.1.a.</b> After digging in the sand, or building sand castles...did {person} wash their hands before eating? (washing of hands may include the use of personal water-free hand sanitizer.)								
<b>d.</b> playing with algae or seaweed .....	1 2 7 8	1 2 7 8	1 2 7 8	1 2 7 8	1 2 7 8	1 2 7 8	1 2 7 8	1 2 7 8
<b>d.1.</b> Did {person} get any seaweed in their mouth?	1 2 7 8	1 2 7 8	1 2 7 8	1 2 7 8	1 2 7 8	1 2 7 8	1 2 7 8	1 2 7 8
<b>IF YES TO d</b>	1 2 7 8	1 2 7 8	1 2 7 8	1 2 7 8	1 2 7 8	1 2 7 8	1 2 7 8	1 2 7 8
<b>d.1.a.</b> After playing with algae...did {person} wash their hands before eating? (washing of hands may include the use of personal water-free hand sanitizer.)								

18.e Was the sand you dug in or played with dry or wet? (interviewer to read the responses)

- 1) All dry
- 2) Mostly dry, some wet
- 3) Mostly wet, some dry
- 4) All wet

Q19. Did {PERSON} cut themselves today or have an open cut when they came to the beach today?

	YES	NO	RF	DK
Person 1.....	1.....	2.....	7.....	8.....
Person 2.....	1.....	2.....	7.....	8.....
Person 3.....	1.....	2.....	7.....	8.....
Person 4.....	1.....	2.....	7.....	8.....
Person 5.....	1.....	2.....	7.....	8.....
Person 6.....	1.....	2.....	7.....	8.....
Person 7.....	1.....	2.....	7.....	8.....
Person 8.....	1.....	2.....	7.....	8.....

Q20. Did {PERSON} wear sunscreen/sunblock today?

	YES	NO	RF	DK
Person 1.....	1.....	2.....	7.....	8.....
Person 2.....	1.....	2.....	7.....	8.....
Person 3.....	1.....	2.....	7.....	8.....
Person 4.....	1.....	2.....	7.....	8.....
Person 5.....	1.....	2.....	7.....	8.....
Person 6.....	1.....	2.....	7.....	8.....
Person 7.....	1.....	2.....	7.....	8.....
Person 8.....	1.....	2.....	7.....	8.....

**If No, Q23, Otherwise GOTO Q21**

Q21. What was the SPF rating of the sunscreen/sunblock you used most often today?

Enter SPF Level \_\_\_\_\_

Q21a. When you used sunscreen/sunblock today, how did you apply it?

- Only to certain areas of my body (for example, head and shoulders)
- All exposed skin

Q22. Did you reapply at least once today?

Person	1	2	3	4	5	6	7	8
	Y N RF DK	Y N RF DK	Y N RF DK	Y N RF DK	Y N RF DK	Y N RF DK	Y N RF DK	Y N RF DK
a. Did you Once?	1 2 7 8	1 2 7 8	1 2 7 8	1 2 7 8	1 2 7 8	1 2 7 8	1 2 7 8	1 2 7 8

Q23. Did {PERSON} wear a hat today?

	YES	NO	RF	DK
Person 1.....	1.....	2.....	7.....	8.....
Person 2.....	1.....	2.....	7.....	8.....
Person 3.....	1.....	2.....	7.....	8.....
Person 4.....	1.....	2.....	7.....	8.....
Person 5.....	1.....	2.....	7.....	8.....
Person 6.....	1.....	2.....	7.....	8.....
Person 7.....	1.....	2.....	7.....	8.....
Person 8.....	1.....	2.....	7.....	8.....

Q23. If yes, Did the hat have a wide brim or another way to shade face, ears, and back of the neck from the sun?

.....	YES	NO	RF	DK
Person 1 .....	1 .....	2 .....	7 .....	8
Person 2 .....	1 .....	2 .....	7 .....	8
Person 3 .....	1 .....	2 .....	7 .....	8
Person 4 .....	1 .....	2 .....	7 .....	8
Person 5 .....	1 .....	2 .....	7 .....	8
Person 6 .....	1 .....	2 .....	7 .....	8
Person 7 .....	1 .....	2 .....	7 .....	8
Person 8 .....	1 .....	2 .....	7 .....	8

Q23a.1 Did {PERSON} use protective equipment such as a canopy, umbrella or other type of sunshade today?

.....	YES	NO	RF	DK
Person 1 .....	1 .....	2 .....	7 .....	8
Person 2 .....	1 .....	2 .....	7 .....	8
Person 3 .....	1 .....	2 .....	7 .....	8
Person 4 .....	1 .....	2 .....	7 .....	8
Person 5 .....	1 .....	2 .....	7 .....	8
Person 6 .....	1 .....	2 .....	7 .....	8
Person 7 .....	1 .....	2 .....	7 .....	8
Person 8 .....	1	2	7	8

Q23b. Did {PERSON} wear protective clothing, such as a long-sleeved shirt or cover-up?

	YES	NO	RF	DK
Person 1 .....	1 .....	2 .....	7 .....	8
Person 2 .....	1 .....	2 .....	7 .....	8
Person 3 .....	1 .....	2 .....	7 .....	8
Person 4 .....	1 .....	2 .....	7 .....	8
Person 5 .....	1 .....	2 .....	7 .....	8
Person 6 .....	1 .....	2 .....	7 .....	8
Person 7 .....	1 .....	2 .....	7 .....	8
Person 8 .....	1 .....	2 .....	7 .....	8

Q24. During the summer, if you/(PERSON) go(es) out in the sun repeatedly without sunscreen or protective clothing which one of these things most usually happens to your/his/her/skin? READ RESPONSES SLOWLY (Choose only one):

	First Name	Code
You		
Person 2		
Person 3		
Person 4		
Person 5		
Person 6		
Person 7		
Person 8		

- 01 A dark tan
- 02 Some tanning
- 03 No tan, maybe some freckles
- 04 Repeated sunburns
- 05 OTHER (Specify)
- 96 NEVER GO OUT IN THE SUN
- 97 REFUSE
- 98 DON'T KNOW

Q25. Did {PERSON} wear insect repellent today?

	YES	NO	RF	DK
Person 1 .....	1.....	2.....	7.....	8.....
Person 2 .....	1.....	2.....	7.....	8.....
Person 3 .....	1.....	2.....	7.....	8.....
Person 4 .....	1.....	2.....	7.....	8.....
Person 5 .....	1.....	2.....	7.....	8.....
Person 6 .....	1.....	2.....	7.....	8.....
Person 7 .....	1.....	2.....	7.....	8.....
Person 8 .....	1.....	2.....	7.....	8.....

Q26. Did you or any member of your household consume food while at the beach today?

	YES	NO	RF	DK
Person 1 .....	1.....	2.....	7.....	8.....
Person 2 .....	1.....	2.....	7.....	8.....
Person 3 .....	1.....	2.....	7.....	8.....
Person 4 .....	1.....	2.....	7.....	8.....
Person 5 .....	1.....	2.....	7.....	8.....
Person 6 .....	1.....	2.....	7.....	8.....
Person 7 .....	1.....	2.....	7.....	8.....
Person 8 .....	1.....	2.....	7.....	8.....

**IF NO, GO to Q27**

Was the food . . . **(Circle all that apply)**

Person	1	2	3	4	5	6	7	8
	Y N RF DK	Y N RF DK	Y N RF DK	Y N RF DK	Y N RF DK	Y N RF DK	Y N RF DK	Y N RF DK
a. brought from home?	1 2 7 8	1 2 7 8	1 2 7 8	1 2 7 8	1 2 7 8	1 2 7 8	1 2 7 8	1 2 7 8
b. purchased from vending machines or a vendor at the beach? .....	1 2 7 8	1 2 7 8	1 2 7 8	1 2 7 8	1 2 7 8	1 2 7 8	1 2 7 8	1 2 7 8
c. purchased from a vendor outside the beach?	1 2 7 8	1 2 7 8	1 2 7 8	1 2 7 8	1 2 7 8	1 2 7 8	1 2 7 8	1 2 7 8

Q27. Did you or any member of your household consume any drinks while at the beach today?

	YES	NO	RF	DK
Person 1 .....	1.....	2.....	7.....	8.....
Person 2 .....	1.....	2.....	7.....	8.....
Person 3 .....	1.....	2.....	7.....	8.....
Person 4 .....	1.....	2.....	7.....	8.....
Person 5 .....	1.....	2.....	7.....	8.....
Person 6 .....	1.....	2.....	7.....	8.....
Person 7 .....	1.....	2.....	7.....	8.....
Person 8 .....	1.....	2.....	7.....	8.....

**IF NO, GO to Q28**

Was the drink . . . **(Circle all that apply)**

Person	1	2	3	4	5	6	7	8
	Y N RF DK	Y N RF DK	Y N RF DK	Y N RF DK	Y N RF DK	Y N RF DK	Y N RF DK	Y N RF DK
a. brought from home?	1 2 7 8	1 2 7 8	1 2 7 8	1 2 7 8	1 2 7 8	1 2 7 8	1 2 7 8	1 2 7 8
b. purchased from vending machines or a vendor at the beach? .....	1 2 7 8	1 2 7 8	1 2 7 8	1 2 7 8	1 2 7 8	1 2 7 8	1 2 7 8	1 2 7 8
c. purchased from a vendor outside the beach? (Ex. Restaurant, deli)	1 2 7 8	1 2 7 8	1 2 7 8	1 2 7 8	1 2 7 8	1 2 7 8	1 2 7 8	1 2 7 8

Q28. In the last 48 hours has anyone done the following . . .

Person	1	2	3	4	5	6	7	8
	Y N RF DK	Y N RF DK	Y N RF DK	Y N RF DK	Y N RF DK	Y N RF DK	Y N RF DK	Y N RF DK
a. Have you come in contact with any animals?	1 2 7 8	1 2 7 8	1 2 7 8	1 2 7 8	1 2 7 8	1 2 7 8	1 2 7 8	1 2 7 8
b. Come into contact with someone who has complained of diarrhea, vomiting, or stomach illness?	1 2 7 8	1 2 7 8	1 2 7 8	1 2 7 8	1 2 7 8	1 2 7 8	1 2 7 8	1 2 7 8
c. Consumed raw shell fish? (Crab, oyster, mussel)	1 2 7 8	1 2 7 8	1 2 7 8	1 2 7 8	1 2 7 8	1 2 7 8	1 2 7 8	1 2 7 8
d. Consumed rare/raw/undercooked or meat that is pink in center? (Fish, beef, chicken)	1 2 7 8	1 2 7 8	1 2 7 8	1 2 7 8	1 2 7 8	1 2 7 8	1 2 7 8	1 2 7 8
e. Consumed runny or raw eggs? .....	1 2 7 8	1 2 7 8	1 2 7 8	1 2 7 8	1 2 7 8	1 2 7 8	1 2 7 8	1 2 7 8

Thank you for your assistance on this national survey of marine and Great Lake beaches. You can contact us regarding information about the study at the toll-free number or e-mail address in the pamphlet. We will phone you in the next 10-12 days with some brief questions about your health. After completing the telephone interview, your household will receive a \$25 check within 30 days of completing the telephone interview.

**Gift received (circle one):**                      COOLER                      TOTE BAG

**QAPP 2**

**Appendix 3**

**NEEAR Telephone Interview**

**NATIONAL EPIDEMIOLOGICAL AND ENVIRONMENTAL ASSESSMENT OF RECREATIONAL  
(NEEAR) WATER STUDY:  
BEACHES SURVEY  
1/30/2007**

**INTRO 1**

**Hello, my name is \_\_\_\_\_. May I speak to \_\_\_\_\_?**

{IF NEEDED: I am calling about a study for the Environmental Protection Agency (EPA). Recently, we spoke to [BEACH RESPONDENT] at {BEACH}, and we're calling back to complete the interview.}

1. AVAILABLE – GO TO INTRO 4
2. NOT AVAILABLE – GO TO INTRO 2
3. NEVER HEARD OF PERSON – GO TO INTRO 3
4. REFUSED – GO TO INTRO 2

**INTRO 2**

[My name is \_\_\_\_\_ and] I am calling about a follow-up study for the Environmental Protection Agency (EPA). Recently, we spoke to (BEACH RESPONDENT) at {BEACH}, and we're calling to complete the interview. If s/he isn't available, I can talk to someone else. Are you a household member 18 years of age or older?

1. YES -- GO TO AINTRO
2. NO – May I speak to an adult 18 years of age or older?
3. REFUSED – COMPLETE NIRF

**INTRO 3**

Is this number (\_\_\_\_) \_\_\_\_ \_\_\_\_ (Verify the number on the call record sheet)?

1. YES – COMPLETE NIRF
2. NO -- REDIAL THE NUMBER

**INTRO 4**

[Hello, my name is \_\_\_\_\_, and] I'm calling about a study for the Environmental Protection Agency (EPA). Recently, we spoke to you at {BEACH} {IF NEEDED: Indiana National Dunes Park (National Lakeshore)}; and we're calling back to complete the interview.

1. CONTINUE
2. SCHEDULE APPOINTMENT
3. REFUSED – COMPLETE NIRF

IF ASKED TO CALL BACK OR SCHEDULE APPOINTMENT, SAY: The interview needs to be completed by [LAST DATE]. When would be the best time to call you before then?



**Aintro.**

[This is \_\_\_\_\_ with the NEEAR Water Study calling.] I'm going to ask some questions about any swimming or bathing during your initial beach visit or other visits you may have had in the last 10-12 days and about illnesses that have been experienced in the last week. I will be asking about the following members of your household ...

[READ NAMES OF HH MEMBERS AT THE BEACH.]

{display list of persons showing first name/age/sex.}

[IS RESPONDENT SAME PERSON INTERVIEWED AT THE BEACH?]

YES	1 (A1)
NO	2 (A1a)

**A1. RespName**

[May I have just your first name, please?]

\_\_\_\_\_

**During Beach Visit where you enrolled in this study on {date}**

**A2.** (For the persons that were swimmers in the beach interview) Did {PERSON} wear ear plugs while in the water?

	Yes	No	RF	DK
Person 1	1	2	7	8
Person 2	1	2	7	8
Person 3	1	2	7	8
Person 4	1	2	7	8
Person 5	1	2	7	8
Person 6	1	2	7	8
Person 7	1	2	7	8
Person 8	1	2	7	8

**A3.** Did {PERSON} wear nose plugs while in the water?

	Yes	No	RF	DK
Person 1	1	2	7	8
Person 2	1	2	7	8
Person 3	1	2	7	8
Person 4	1	2	7	8
Person 5	1	2	7	8
Person 6	1	2	7	8
Person 7	1	2	7	8
Person 8	1	2	7	8

**A4.** Did {PERSON} wear eye goggles or use a face mask while in the water?

	Yes	No	RF	DK
Person 1	1	2	7	8
Person 2	1	2	7	8
Person 3	1	2	7	8
Person 4	1	2	7	8
Person 5	1	2	7	8
Person 6	1	2	7	8
Person 7	1	2	7	8

Person 8 1 2 7 8

**A5.** During the beach interview, {PERSON} had contact with an animal?

Person 1	Drop down list	Were they unfamiliar to you? Yes No RF DK
Person 2	Drop down list	Were they unfamiliar to you? Yes No RF DK
Person 3	Drop down list	Were they unfamiliar to you? Yes No RF DK
Person 4	Drop down list	Were they unfamiliar to you? Yes No RF DK
Person 5	Drop down list	Were they unfamiliar to you? Yes No RF DK
Person 6	Drop down list	Were they unfamiliar to you? Yes No RF DK
Person 7	Drop down list	Were they unfamiliar to you? Yes No RF DK
Person 8	Drop down list	Were they unfamiliar to you? Yes No RF DK

NEXT QUESTION FOR FEMALE PARTICIPANTS ONLY

**A6.** Between your beach visit on XXXX date and today were you menstruating (or some other word) or pregnant?

<b>1</b>	<b>2</b>	<b>3</b>	<b>4</b>	<b>5</b>	<b>6</b>	<b>7</b>	<b>8</b>
<b>Y N</b>	<b>Y N</b>	<b>Y N</b>	<b>Y N</b>	<b>Y N</b>	<b>Y N</b>	<b>Y N</b>	<b>Y N</b>
1 2	1 2	1 2	1 2	1 2	1 2	1 2	1 2

**We are now going to switch and ask you questions about activities that have occurred since the Beach Interview.**

**B1. AnyoneSwim**

.....  
 Have you or any of the people I just mentioned gone bathing or swimming anywhere since we talked to [you/ORIGINAL RESPONDENT] at the beach interview on {BEACH INTERVIEW DATE}? Please include any bathing or swimming such as at a beach, waterpark, public pool, private pool, or wading pool.

- |            |                 |
|------------|-----------------|
| YES        | 1 (B2)          |
| NO         | 2 (SymtomIntro) |
| REFUSED    | 7 (SymtomIntro) |
| DON'T KNOW | 8 (SymtomIntro) |

**B2. WhoSwam**

Who was it that went bathing or swimming? \_\_\_\_\_

[CODE ALL THAT APPLY.]

{response options are the names of all persons}

ASK B3 THROUGH B5 ABOUT EACH PERSON WHO WAS MARKED IN B2. BEGIN WITH THE FIRST PERSON IN THE LIST WHO WAS MARKED AND CONTINUE WITH ALL OTHER MARKED PERSONS.

**B3a. SameBeach**

Did [PERSON] go bathing or swimming at {BEACH} since the beach interview on {BEACH INTERVIEW DATE}?

YES	1
NO	2
REFUSED	7
DON'T KNOW	8

**B3b. DifferentBeach**

Did [PERSON] go bathing or swimming at any other beach?

YES	1 (B3c)
NO	2 (B3d)
REFUSED	7 (B3d)
DON'T KNOW	8 (B3d)

**B3c. BeachType**

Was this beach at a:

Lake	1
River, or	2
Ocean?	3
OTHER, SPECIFY	6
REFUSED	7
DON'T KNOW	8

**B3d. Waterpark**

Did [PERSON] go bathing or swimming at a waterpark?

YES	1
NO	2
REFUSED	7
DON'T KNOW	8

**B3e. PublicPool**

[Did {PERSON} go bathing or swimming ...] at a public pool?

YES	1
NO	2
REFUSED	7
DON'T KNOW	8

**B3f. PrivatePool**

[Did {PERSON} go bathing or swimming ...] at a private pool?

YES	1
NO	2
REFUSED	7
DON'T KNOW	8

**B3g. WadingPool**

[Did {PERSON} go bathing or swimming ...] in a wading pool?

[NOTE TO INT: THIS COULD BE A BACKYARD INFLATED POOL.]

YES	1
NO	2
REFUSED	7
DON'T KNOW	8

**B3h. AnyOtherSwimming**

[Did {PERSON} go bathing or swimming ...] any other place?

YES	1 (B3i)
NO	2 (B4)
REFUSED	7 (B4)
DON'T KNOW	8 (B4)

CATI EDIT CHECK: IF R ANSWERED YES TO B3a, BUT NO TO B3b THROUGH B3h, ASK, "You've said that (PERSON) went bathing or swimming sometime since (BEACH INTERVIEW DATE). Where did (you/s/he) go swimming?" CODA B3b-B3h

**B3i. OtherSwimLocation**

[SPECIFY:] \_\_\_\_\_

**B4. GetFaceWet**

Did [you/{PERSON}] actually get [your/{his/her}] face wet while bathing or swimming?

YES	1
NO	2
REFUSED	7
DON'T KNOW	8

**B5. DaysSwam**

On which days did [you/{PERSON}] go bathing or swimming? [since {BEACH INTERVIEW DATE}]

\_\_\_\_\_

[CODE ALL THAT APPLY]

INTERVIEWER WILL REFER TO HARD-COPY CALENDAR FOR ALL DATES.

PROG. NOTE: Do not allow a date prior to the BEACH INTERVIEW DATE. Do not allow a date later than today.

**SymptomIntro**

I'm going to go through a list of symptoms. Please tell me if anyone has had any of these symptoms since the interview at {BEACH} on {BEACH INTERVIEW DATE}. Again, the people I am asking about are...

[Questions **B6 to B23** are asked about all household members who were at the beach on the BEACH INTERVIEW DATE.]

**B6. AnyStomachAche**

Have you or anyone else had a stomachache or abdominal cramping since the interview at {BEACH} on {BEACH INTERVIEW DATE}?

- YES 1 (B6a)
- NO 2 (B7)
- REFUSED 7 (B7)
- DON'T KNOW 8 (B7)

**B6a. StomachList**

Who? [had a stomachache or abdominal cramps since the interview at {BEACH} on {BEACH INTERVIEW DATE}??]

[CODE ALL THAT APPLY.]

{response options are the names of all persons (first name/age/sex).}

- REFUSED 7
- DON'T KNOW 8

**B7. AnyDiarrhea**

Has anyone had diarrhea or loose bowels since the interview at {BEACH} on {BEACH INTERVIEW DATE}? By diarrhea we mean, three or more loose or watery stools in a 24-hour period.

YES	1 (B7a)
NO	2 (B8)
REFUSED	7 (B8)
DON'T KNOW	8 (B8)

### B7a. DiarrheaList

Who [had diarrhea or loose bowels since the interview at {BEACH} on {BEACH INTERVIEW DATE}??]

[CODE ALL THAT APPLY.]

{response options are the names of all persons (PERSON).}

REFUSED	7
DON'T KNOW	8

### B8. AnyNausea

Has anyone had nausea since the interview at {BEACH} on {BEACH INTERVIEW DATE}?

YES	1 (B8a)
NO	2 (B9)
REFUSED	7 (B9)
DON'T KNOW	8 (B9)

### B8a. NauseaList

Who? [had nausea since the interview at {BEACH} on {BEACH INTERVIEW DATE}??]

[CODE ALL THAT APPLY.]

{response options are the names of all persons (first name/age/sex).}

REFUSED	7
DON'T KNOW	8

### B9. AnyVomiting

Has anyone had throwing up or vomiting? [since the interview at {BEACH} on {BEACH INTERVIEW DATE}??]

YES	1 (B9a)
NO	2 (B10)
REFUSED	7 (B10)
DON'T KNOW	8 (B10)

### B9a. VomitingList

Who had throwing up or vomiting [since the interview at {BEACH} on {BEACH INTERVIEW DATE}??]

[CODE ALL THAT APPLY.]

{response options are the names of all persons (first name/age/sex).}

REFUSED	7
DON'T KNOW	8

### **B10. AnyUTI**

Has anyone had a urinary tract infection or burning sensation when urinating since the interview at {BEACH} on {BEACH INTERVIEW DATE}?

YES	1 (B10a)
NO	2 (B11)
REFUSED	7 (B11)
DON'T KNOW	8 (B11)

### **B10a. UTIList**

Who? [had a urinary tract infection or burning sensation when urinating since the interview at {BEACH} on {BEACH INTERVIEW DATE}??]

[CODE ALL THAT APPLY.]

{response options are the names of all persons (first name/age/sex).}

REFUSED	7
DON'T KNOW	8

### **B11. AnyFever**

[Has anyone had ...] a fever? [since the interview at {BEACH} on {BEACH INTERVIEW DATE}??]

YES	1 (B11a)
NO	2 (B12)
REFUSED	7 (B12)
DON'T KNOW	8 (B12)

### **B11a. FeverList**

Who? [had a fever since the interview at {BEACH} on {BEACH INTERVIEW DATE}??]

[CODE ALL THAT APPLY.]

{response options are the names of all persons}

REFUSED	7
DON'T KNOW	8

### **B12. AnyHeadache**

[Has anyone had ...] a headache lasting more than a few hours? [since the interview at {BEACH} on {BEACH INTERVIEW DATE}??]

YES	1 (B12a)
NO	2 (B13)

REFUSED	7 (B13)
DON'T KNOW	8 (B13)

### B12a. HeadacheList

Who? [had a headache since the interview at {BEACH} on {beach interview date}??]

[CODE ALL THAT APPLY.]

{response options are the names of all persons}

REFUSED	7
DON'T KNOW	8

### B13. AnySoreThroat

[Has anyone had ...] a sore throat? [since the interview at {BEACH} on {beach interview date}??]

YES	1 (B13a)
NO	2 (B14)
REFUSED	7 (B14)
DON'T KNOW	8 (B14)

### B13a. SoreThroatList

Who? [had a sore throat since the interview at {BEACH} on {beach interview date}??]

[CODE ALL THAT APPLY.]

{response options are the names of all persons}

REFUSED	7
DON'T KNOW	8

### B14. AnyCough

[Has anyone had ] a bad cough? [since the interview at {BEACH} on {BEACH INTERVIEW DATE}??]

YES	1 (B14a)
NO	2 (B15)
REFUSED	7 (B15)
DON'T KNOW	8 (B15)

### B14a. CoughList

Who? [had a cough since the interview at {BEACH} on {beach interview date}??]

[CODE ALL THAT APPLY.]

{response options are the names of all persons}



REFUSED	7
DON'T KNOW	8

### B15. AnyCold

[Has anyone had ...] a cold? [since the interview at {BEACH} on {BEACH INTERVIEW DATE}?]

YES	1 (B15a)
NO	2 (B16)
REFUSED	7 (B16)
DON'T KNOW	8 (B16)

### B15a. ColdList

Who? [had a cold since the interview at {BEACH} on {BEACH INTERVIEW DATE}?]

[CODE ALL THAT APPLY.]

{response options are the names of all persons}

REFUSED	7
DON'T KNOW	8

### B16. AnyRunnyNose

[Has anyone had...] a runny or stuffy nose? [since the interview at {BEACH} on {BEACH INTERVIEW DATE}?]

YES	1 (B16a)
NO	2 (B17)
REFUSED	7 (B17)
DON'T KNOW	8 (B17)

### B16a. RunnyNoseList

Who? [had a runny nose since the interview at {BEACH} on {BEACH INTERVIEW DATE}?]

[CODE ALL THAT APPLY.]

{response options are the names of all persons}

REFUSED	7
DON'T KNOW	8

### B17. AnyEarache

[Has anyone had ...] an earache, ear infection, or runny ears? [since the interview at {BEACH} on {BEACH INTERVIEW DATE}?]

YES	1 (B17a)
NO	2 (B18)

REFUSED	7 (B18)
DON'T KNOW	8 (B18)

**B17a. EaracheList**

[Who? [ had an earache since the interview at {BEACH} on {BEACH INTERVIEW DATE}?]

[CODE ALL THAT APPLY.]

{response options are the names of all persons}

REFUSED	7
DON'T KNOW	8

**B18. AnyWateryEyes**

[Has anyone had ...] watery eyes? [since the interview at {BEACH} on {BEACH INTERVIEW DATE}?]

YES	1 (B18a)
NO	2 (B19)
REFUSED	7 (B19)
DON'T KNOW	8 (B19)

**B18a. WateryEyesList**

Who? [ had watery eyes since the interview at {BEACH} on {beach interview date}?]

[CODE ALL THAT APPLY.]

{response options are the names of all persons}

REFUSED	7
DON'T KNOW	8

**B19. AnyEyeInfection**

[Has anyone had ...] an eye infection? [since the interview at {BEACH} on {BEACH INTERVIEW DATE}?]

YES	1 (B19a)
NO	2 (B20)
REFUSED	7 (B20)
DON'T KNOW	8 (B20)

**B19a. EyeList**

Who? [ had any eye infection since the interview at {BEACH} on {BEACH INTERVIEW DATE}?]

[CODE ALL THAT APPLY.]

{response options are the names of all persons}

REFUSED	7
DON'T KNOW	8

## B20. AnyCuts

(We need to know if the cut became infected after the visit to the beach; When did the cut occur, it could have occurred after they were at the beach. Check to make sure the information is conveyed correctly from Beach Interview) [Has anyone had ...] an infected cut? [since the interview at {BEACH} on {BEACH INTERVIEW DATE}?]

YES	1 (B20a)
NO	2 (B21)
REFUSED	7 (B21)
DON'T KNOW	8 (B21)

### B20a. CutList

Who? [Had an infected cut since the interview at {BEACH} on {BEACH INTERVIEW DATE}?]

[CODE ALL THAT APPLY.]

{response options are the names of all persons}

REFUSED	7
DON'T KNOW	8

## B21. AnyRash

[Has anyone had ...] a rash or itchy skin? [since the interview at {BEACH} on {BEACH INTERVIEW DATE}?]

YES	1 (B21a)
NO	2 (B22)
REFUSED	7 (B22)
DON'T KNOW	8 (B22)

### B21a. RashList

[Who? [Had a rash since the interview at {BEACH} on {BEACH INTERVIEW DATE}?]

[CODE ALL THAT APPLY.]

{response options are the names of all persons}

REFUSED	7
DON'T KNOW	8

## B22. AnySunburn

[Has anyone had ...] a sunburn? [since the interview at {BEACH} on {beach interview date}?]

YES	1 (B22a)
-----	----------

NO	2 (B23)
REFUSED	7 (B23)
DON'T KNOW	8 (B23)

**B22a. AnySunburnList**

Who? [ had sunburn since the interview at {BEACH} on {BEACH INTERVIEW DATE}??]

[CODE ALL THAT APPLY.]

{response options are the names of all persons}

REFUSED	7
DON'T KNOW	8

**B23. ActivitiesIntro**

I'd like to ask you about some activities people may have done since the day of the beach interview on (BEACH INTERVIEW DATE).

**B23a. AnyContactAni**

[Since the day of the beach interview] Has anyone come into contact with any animals?

YES	1 (B23b)
NO	2 (B24)
REFUSED	7 (B24)
DON'T KNOW	8 (B24)

**B23b. AnimalContactList**

Who? [ came into contact with animals since {BEACH INTERVIEW DATE}??]

[CODE ALL THAT APPLY.]

{response options are the names of all persons}

REFUSED	7
DON'T KNOW	8

**B23c. ASK FOR EACH PERSON IN A23a:** (Was this animal/Were any of these animals) unfamiliar to (you/him/her)?

YES	1
NO	2
REFUSED	7
DON'T KNOW	8

**B23d. What kind of animal or animals were they?**

**DROP-DOWN MENU WILL ALLOW FOR CHECKING ALL THAT APPLY**

1. FISH (AQUARIUM)
2. CATS
3. DOGS
4. POULTRY (CHICKENS, TURKEYS)
5. HORSES

6. COWS
7. SHEEP
8. GOATS
9. AMPHIBIANS (FROGS, SALAMANDERS)
10. REPTILES (SNAKES, TURTLES, LIZARDS)
11. BIRDS (PETS)
12. OTHER, SPECIFY: \_\_\_\_\_

**B24a. (Since the day of the beach interview) Has anyone come into contact with someone who has complained of diarrhea, vomiting, or stomach illness?**

YES	1 (B24b)
NO	2 (B25)
REFUSED	7 (B25)
DON'T KNOW	8 (B25)

**B24b. PeopleContactList**

Who? [had contact with someone complaining of diarrhea, vomiting or stomach illness since (BEACH INTERVIEW DATE)?

[CODE ALL THAT APPLY.]

{response options are the names of all persons}

REFUSED	7
DON'T KNOW	8

**B25a. (Since the day of the beach interview) Has anyone eaten raw shell fish, such as oysters, clams, mussels, crabs?**

YES	1 (B25b)
NO	2 (B26)
REFUSED	7 (B26)
DON'T KNOW	8 (B26)

**B25b. ShellfishList**

Who? [has eaten raw shellfish since (BEACH INTERVIEW DATE)?

[CODE ALL THAT APPLY.]

{response options are the names of all persons}

REFUSED	7
DON'T KNOW	8

**B26a. (Since the day of the beach interview) Has anyone eaten rare or raw meat? This includes pink in the center/**

YES	1 (B26b)
NO	2 (B27)
REFUSED	7 (B27)
DON'T KNOW	8 (B27)

**B26b. RawMeatList**

Who? [has eaten rare (pink in center) or raw meat since (BEACH INTERVIEW DATE)?

[CODE ALL THAT APPLY.]

{response options are the names of all persons}

REFUSED	7
DON'T KNOW	8

**B27a. (Since the day of the beach interview) Has anyone eaten runny or raw eggs?**

YES	1 (B27b)
NO	2 (C1INTRO)
REFUSED	7 (C1INTRO)
DON'T KNOW	8 (C1INTRO)

**B27b. EggsList**

Who? [has eaten runny or raw eggs since (BEACH INTERVIEW DATE)?

[CODE ALL THAT APPLY.]

{response options are the names of all persons}

REFUSED	7
DON'T KNOW	8

**IF ANY PERSON WAS MARKED AS HAVING ANY SYMPTOM (B6-B22), ASK ALL PERTINENT SYMPTOM QUESTIONS FOR THAT PERSON. BEGIN WITH THE FIRST PERSON IN THE ENUMERATION WHO WAS MARKED AS HAVING HAD A SYMPTOM, THEN CONTINUE WITH EACH OTHER PERSON MARKED.**

**IF NO PERSON WAS MARKED AS HAVING ANY SYMPTOMS, GO TO QUESTION E1.**

**SECTION C.**

**C INTRO.**

You said that {you/PERSON} experienced some symptoms since {BEACH INTERVIEW DATE}. Now I would like to ask you about those symptoms.

**IF THIS PERSON HAD A STOMACHACHE, GO TO C1 OR ELSE, GO TO C2.**

**C1. StomachStartDay**

On what day did {name/age/sex}'s stomachache or abdominal cramping start?

DATE: \_\_\_\_\_  
REFUSED 7 (C2)  
DON'T KNOW 8 (C2)

INTERVIEWER WILL REFER TO HARD-COPY CALENDAR FOR ALL DATES.

PROG. NOTE: Do not allow a date prior to the BEACH INTERVIEW DATE. Do not allow a date later than today.

**C1a. StomachStill**

Does {name/age/sex} still have a stomachache or abdominal cramping?

YES

1

NO	2
REFUSED	7
DON'T KNOW	8

INTERVIEWER WILL REFER TO HARD-COPY CALENDAR TO NEGOTIATE DATES.

**IF THIS PERSON STILL HAS A STOMACHACHE, GO TO C2.**

**C1b. StomachDays**

For how many days did {name/age/sex}'s stomachache or abdominal cramping last?

\_\_\_\_|

REFUSED	7
DON'T KNOW	8

NOTE: FOR SYMPTOMS LASTING A HALF DAY OR LESS, CODE "00".

IF THIS PERSON HAD DIARRHEA, GO TO C2. OR ELSE, GO TO C3.

**C2. DiarrheaStartDay**

On what day did {name/age/sex}'s diarrhea or loose bowels start?

DATE: \_\_\_\_\_

REFUSED	7 (C3)
DON'T KNOW	8 (C2a)

**C2a. DiarrheaStill**

Does {name/age/sex} still have diarrhea?

YES	1
NO	2
REFUSED	7
DON'T KNOW	8

**IF THIS PERSON STILL HAS DIARRHEA, GO TO C2c**

**C2b. DiarrheaDays**

For how many days did {name/age/sex}'s diarrhea last?

\_\_\_\_|

REFUSED	7
DON'T KNOW	8

**C2c. DiarrheaNumber**

What was the maximum number of bouts or episodes of diarrhea {name/age/sex} experienced in a 24-hour period?



[NUMBER PER DAY:] |\_\_|\_\_|\_\_|

REFUSED 7  
DON'T KNOW 8

IF THIS PERSON HAD NAUSEA, GO TO C3. OR ELSE, GO TO C4.

**C3. NauseaStartDay**

On what day did {name/age/sex}'s nausea start?

DATE: \_\_\_\_\_  
REFUSED 7 (C4)  
DON'T KNOW 8 (C4)

**C3a. NauseaStill**

Does {name/age/sex} still have nausea?

YES 1  
NO 2  
REFUSED 7  
DON'T KNOW 8

IF THIS PERSON STILL HAS NAUSEA, GO TO C4.

**C3b. NauseaDays**

For how many days did {name/age/sex}'s nausea last?

|\_\_|\_\_|\_\_|

REFUSED 7  
DON'T KNOW 8

IF THIS PERSON HAD VOMITING, GO TO C4. OR ELSE, GO TO C5.

**C4. VomitingStartDay**

On what day did {name/age/sex}'s throwing up or vomiting start?

DATE: \_\_\_\_\_  
REFUSED 7 (C5)  
DON'T KNOW 8 (C5)

**C4a. VomitingStill**

Is {name/age/sex} still vomiting?

YES 1  
NO 2  
REFUSED 7

DON'T KNOW 8

**IF THIS PERSON STILL IS VOMITING, GO TO C4c.**

**C4b. VomitingDays**

For how many days did {name/age/sex}'s vomiting last?

[NUMBER] |\_\_|\_\_|\_\_|  
REFUSED 7  
DON'T KNOW 8

**C4c. VomitingNumber**

What was the maximum number of times that {name/age/sex} vomited during a 24-hour period?

[NUMBER] |\_\_|\_\_|\_\_|  
REFUSED 7  
DON'T KNOW 8

**IF THIS PERSON HAD A UTI, GO TO C5. OR ELSE, GO TO C6.**

**C5. UrinaryTractInfectionStartDay**

On what day did {name/age/sex}'s urinary tract infection or burning start?

DATE: \_\_\_\_\_  
REFUSED 7 (C6)  
DON'T KNOW 8 (C6)

**C5a. UrinaryTractInfectionStill**

Does {name/age/sex} still have a urinary tract infection or burning sensation?

YES 1  
NO 2  
REFUSED 7  
DON'T KNOW 8

**IF THIS PERSON STILL HAS A UTI, GO TO C6.**

**C5b. UrinaryTractInfectionDays**

For how many days did {name/age/sex}'s urinary tract infection or burning sensation?

|\_\_|\_\_|\_\_|  
REFUSED 7

DON'T KNOW

8

**IF THIS PERSON HAD A FEVER, GO TO C6. OR ELSE, GO TO C7.**

**C6. FeverStartDay**

On what day did {name/age/sex}'s fever start?

DATE: _____	
REFUSED	7 (C7)
DON'T KNOW	8 (C7)

**C6a. FeverStill**

Does {name/age/sex} still have a fever?

YES	1
NO	2
REFUSED	7
DON'T KNOW	8

**IF THIS PERSON STILL HAS A FEVER, GO TO C6c.**

**C6b. FeverDays**

For how many days did {name/age/sex}'s fever last?

_ _ _	
REFUSED	7
DON'T KNOW	8

**C6c. FeverTempTaken**

Was {name/age/sex}'s temperature taken using a thermometer?

YES	1 (C6d)
NO	2 (C7)
REFUSED	7 (C7)
DON'T KNOW	8 (C7)

**C6d. FeverTemp**

What is the highest temperature that {name/age/sex} has had since {BEACH INTERVIEW DATE}?

[TEMPERATURE:] \_\_\_\_\_

Range: 98.6 to 106.9

REFUSED	7
DON'T KNOW	8

**IF THIS PERSON HAD A HEADACHE, GO TO C7. OR ELSE, GO TO C8.**

**C7. HeadacheStartDay**

On what day did {name/age/sex}'s headache start?

DATE: _____	
REFUSED	7 (C8)
DON'T KNOW	8 (C8)

**C7a. HeadacheStill**

Does {name/age/sex} still have a headache?

YES	1
NO	2
REFUSED	7
DON'T KNOW	8

**IF THIS PERSON STILL HAS A HEADACHE, GO TO C8.**

**C7b. HeadacheDays**

For how many days did {name/age/sex}'s headache last?

_ _ _	
REFUSED	7
DON'T KNOW	8

**IF THIS PERSON HAD A SORE THROAT, GO TO C8. OR ELSE, GO TO C9.**

**C8. SoreThroatStartDay**

On what day did {name/age/sex}'s sore throat start?

DATE: _____	
REFUSED	7 (C9)
DON'T KNOW	8 (C9)

**C8a. SoreThroatStill**

Does {name/age/sex} still have a sore throat?

YES	1
NO	2
REFUSED	7
DON'T KNOW	8

**IF THIS PERSON STILL HAS A SORE THROAT, GO TO C8c.**

**C8b. SoreThroatDays**

For how many days did {name/age/sex}'s sore throat last?

|\_|\_|\_|

REFUSED	7
DON'T KNOW	8

**C8c. SoreThroatAllergy**

Was this sore throat related to allergies?

YES	1
NO	2
REFUSED	7
DON'T KNOW	8

**IF THIS PERSON HAD A BAD COUGH, GO TO C9. OR ELSE, GO TO C10.**

**C9. CoughStartDay**

On what day did {name/age/sex}'s bad cough start?

DATE: _____	
REFUSED	7 (C10)
DON'T KNOW	8 (C10)

**C9a. CoughStill**

Does {name/age/sex} still have a bad cough?

YES	1
NO	2
REFUSED	7
DON'T KNOW	8

**IF THIS PERSON STILL HAS A BAD COUGH, GO TO C9c.**

**C9b. CoughDays**

For how many days did {name/age/sex}'s cough last?

	_ _ _
REFUSED	7
DON'T KNOW	8

**C9c. CoughAllergy**

Was this bad cough related to allergies?

YES	1
NO	2
REFUSED	7
DON'T KNOW	8

**IF THIS PERSON HAD A COLD, GO TO C10. OR ELSE, GO TO C11.**

**C10. ColdStartDay**

On what day did {name/age/sex}'s cold start?

DATE: _____	
REFUSED	7 (C11)
DON'T KNOW	8 (C11)

**C10a. ColdStill**

Does {name/age/sex} still have a cold?

YES	1
NO	2
REFUSED	7
DON'T KNOW	8

**IF THIS PERSON STILL HAS A COLD STILL, GO TO C10c.**

**C10b. ColdDays**

For how many days did {name/age/sex}'s cold last?

_____	
REFUSED	7
DON'T KNOW	8

**C10c. ColdAllergy**

Was this cold related to allergies?

YES	1
NO	2
REFUSED	7
DON'T KNOW	8

**IF THIS PERSON HAD A RUNNY OR STUFFY NOSE, GO TO C11, OR ELSE, GO TO C12.**

**C11. RunnyNoseStartDay**

On what day did {name/age/sex}'s runny or stuffy nose start?

DATE: _____	
REFUSED	7 (C12)
DON'T KNOW	8 (C12)

**C11a. RunnyNoseStill**

Does {name/age/sex} still have a runny or stuffy nose?

YES	1
NO	2
REFUSED	7
DON'T KNOW	8

**IF THIS PERSON STILL HAS A RUNNY NOSE, GO TO C11c.**

**C11b. RunnyNoseDays**

For how many days did {name/age/sex}'s runny or stuff nose last?

|\_|\_|\_|

REFUSED	7
DON'T KNOW	8

**C11c. RunnyNoseAllergy**

Was this runny or stuffy nose related to allergies?

YES	1
NO	2
REFUSED	7
DON'T KNOW	8

**IF THIS PERSON HAD A EARACHE, GO TO C12. OR ELSE, GO TO C13.**

**C12. EaracheStartDay**

On what day did {name/age/sex}'s earache, ear infection or runny ears start?

DATE: \_\_\_\_\_

REFUSED	7 (C13)
DON'T KNOW	8 (C13)

**C12a. EaracheStill**

Does {name/age/sex} still have an earache, ear infection or runny ears?

YES	1
NO	2
REFUSED	7
DON'T KNOW	8

**IF THIS PERSON STILL HAS AN EARACHE, GO TO C12c.**

**C12b. EaracheDays**

For how many days did {name/age/sex}'s earache, ear infection or runny ears last?

|\_|\_|\_|

REFUSED 7  
DON'T KNOW 8

**C12c. EaracheAllergy**

Was this earache, ear infection or runny ears related to allergies?

YES 1  
NO 2  
REFUSED 7  
DON'T KNOW 8

IF THIS PERSON HAD WATERY EYES, GO TO C13. OR ELSE, GO TO C14.

**C13. WateryEyesStartDay**

On what day did {name/age/sex}'s watery eyes start?

DATE: \_\_\_\_\_  
REFUSED 7 (C14)  
DON'T KNOW 8 (C14)

**C13a. WaterEyesStill**

Does {name/age/sex} still have watery eyes?

YES 1  
NO 2  
REFUSED 7  
DON'T KNOW 8

IF THIS PERSON STILL HAS WATERY EYES, GO TO C13c.

**C13b. WateryEyesDays**

For how many days did {name/age/sex}'s watery eyes last?

|\_|\_|\_|

REFUSED 7  
DON'T KNOW 8

**C13c. WateryEyesAllergy**



Were the watery eyes related to allergies?

YES	1
NO	2
REFUSED	7
DON'T KNOW	8

IF THIS PERSON HAD AN EYE INFECTION, GO TO C14. OR ELSE, GO TO C15.

**C14. EyeInfectionStartDay**

On what day did {name/age/sex}'s eye infection start?

DATE: _____	
REFUSED	7 (C15)
DON'T KNOW	8 (C15)

**C14a. EyeInfectionStill**

Does {name/age/sex} still have the eye infection?

YES	1
NO	2
REFUSED	7
DON'T KNOW	8

**IF THIS PERSON STILL HAS AN EYE INFECTION, GO TO C15.**

**C14b. EyeInfectionDays**

For how many days did {name/age/sex}'s eye infection last?

|\_|\_|\_|

REFUSED	7
DON'T KNOW	8

**IF THIS PERSON HAD AN INFECTED CUT, GO TO C15. OR ELSE, GO TO C16.**

**(Make sure information about the cut date is being relayed)**

**C15. CutStartDay (Maybe CutInfectDay)**

On what day did {name/age/sex}'s cut first get infected?

DATE: _____	
REFUSED	7 (C16)
DON'T KNOW	8 (C16)

**C15a. CutStill**

Does {name/age/sex} still have an infected cut?

- YES 1
- NO 2
- REFUSED 7
- DON'T KNOW 8

**IF THIS PERSON STILL HAS AN INFECTED CUT, GO TO C15c.**

**C15b. CutDays**

For how many days did {name/age/sex}'s infected cut last?

\_\_\_\_

- REFUSED 7
- DON'T KNOW 8

**C15c. Where were [you/PERSON#n] cut?**

[Mark all that apply.]

Location	Check if positive
1. ankle	
2. arms	
3. armpits	
4. back	4a. Was that the upper or lower back?
5. breast	
6. buttocks	
7. chest	
8. ears	
9. face	
10. feet	10a. Was it on the soles or the top of the feet/foot?
11. genitalia	

12. groin	
13. hands	13a. Was it on the back of the hand, the palm, or the fingers?
14. legs	
15. mouth	
16. neck	
17. scalp	
18. stomach	
19. throat	
20. other	specify:
21. refused	

**IF THIS PERSON HAD RASH, GO TO C16. OR ELSE, GO TO C17.**

**C16. RashStartDay**

On what day did {name/age/sex}'s rash, itchy skin, or skin infection start?

DATE: \_\_\_\_\_  
 REFUSED 7 (C17)  
 DON'T KNOW 8 (C17)

**C16a. RashStill**

Does {name/age/sex} still have the rash, itchy skin, or skin infection?

YES 1  
 NO 2 (C17)  
 REFUSED 7 (C17)  
 DON'T KNOW 8 (C17)

**IF THIS PERSON STILL HAS SKIN PROBLEM, GO TO C16c.**

**C16b. RashDays**

For how many days did {name/age/sex}'s rash, itchy skin, or skin infection last?

□□□□

REFUSED 7  
 DON'T KNOW 8

**C16c. Where were/was your/{name/age/sex}'s rash?**

[Mark all that apply.]

Location	Check if positive
1. ankle	
2. arms	
3. armpits	
4. back	4a. Was that the upper or lower back?
5. breast	
6. buttocks	
7. chest	
8. ears	
9. face	
10. feet	10a. Was that on the sole or the top of the foot?
11. genitalia	
12. groin	
13. hands	13a. Was that on the back of the hand, the fingers or the palm?
14. legs	
15. mouth	
16. neck	
17. scalp	
18. stomach	
19. throat	
20. other	specify:
21. refused	
22. don't know	

**IF THIS PERSON HAD SUNBURN, GO TO C17. OR ELSE, GO TO QUESTION D1.**

**(When did they get sunburned. Was the information relayed)**

**C17. Sunburn**

On which parts of the body was {name/age/sex} sunburned?

[Mark all that apply.]

Location	Check if positive
1. Face or head	
2. Neck or	

shoulders	
3. Back	
5. Chest or abdomen	
6. Arms or hands	
7. Legs or feet	
8. Other	Specify:
9. Refuse	
11. Don't know	

**ASK D1 ONLY ONCE FOR EACH PERSON REPORTING SYMPTOMS (C1-C172). START WITH PERSON #1.**

**D1.** When (your/PERSON's) (illness/condition) began, (were you/was s/he) working for pay either inside or outside the home? Please include jobs for which (you were/s/he was) self-employed.

YES	1
NO	2
REFUSED	7
DON'T KNOW	8

**[PROG NOTE: Remaining Section D questions will be asked for all household members (1-12) reporting symptoms of the following syndromes:**

- Gastrointestinal/Diarrhea (symptoms – stomach ache, diarrhea, nausea, vomiting)**
- Eye Infection (symptoms – watery eyes, eye infection)**
- Upper Respiratory (symptoms – sore throat, cough, runny nose, cold)**
- Ear Infection (symptom – earache)**
- Urinary Tract Infection (symptom – urinary tract infection)**
- Skin (symptom – cuts, rash, sunburn)**

**Data will not be collected on headache and fever if they occur in isolation and are not linked to specific syndromes.]**

**(Do this for each symptom for each person)**

**DINTRO**You said [you/PERSON] had [LIST OF SYMPTOMS MAKING UP SYNDROME].  
 [READ FOR FIRST SYNDROME FOR FIRST PERSON: We would now like to discuss how this (illness/condition) affected (your/his/her) daily activities.]

<b>DOES D1=01 (Working for pay/business)</b>
<b>Yes go to D2</b>
No go to D4

**D2.** During (your/his/her) illness, did (you/s/he) miss any time from work, for example because (you/s/he) called in sick or took time off to see a doctor?

YES	1 (D3)
NO	2 (D4)
REFUSED	7 (D4)
DON'T KNOW	8 (D4)

**D3.** How many days? |\_|\_|\_| days (IF IN HOURS, i.e. <1 DAY, THEN CODE AS ZERO)

REFUSED	7
DON'T KNOW	8

**D4.** Did this illness prevent (you/him/her) from performing daily activities such as school, recreation, or vacation activities, or work around the home?

YES	1
NO	2 (D6)
REFUSED	7 (D6)
DON'T KNOW	8 (D6)

**D5.** How many days?

\_\_\_\_ days (IF IN HOURS, i.e. <1 DAY, THEN CODE AS ZERO)

REFUSED	7
DON'T KNOW	8

**D6.** Did (your/his/her) illness cause other household members to lose time at work?

YES	1
NO	2 (D8a)
REFUSED	7 (D8a)
DON'T KNOW	8 (D8a)

**D7.** IF Yes: How many days?

\_\_\_\_ days (IF IN HOURS, i.e. <1 DAY, THEN CODE AS ZERO)

REFUSED	7
DON'T KNOW	8

Next, I am going to ask you some questions about the treatment and diagnosis of (your/his/her) illness.

You said that (you/PERSON) suffered from (SYMPTOMS MAKING UP EACH ILLNESS).

**D8a.** Did (you/s/he) consult a healthcare provider over the phone about this (illness/condition)?

YES	1
NO	2
REFUSED	7
DON'T KNOW	8

**D8b.** Did (you/s/he) **visit** a health care provider?

YES	1
NO	2 (D8e)
REFUSED	7 (D8e)
DON'T KNOW	8 (D8e)

**D8c.** How many times?

\_\_\_\_\_ #TIMES

REFUSED	7
DON'T KNOW	8

**D8d.** What illness did the health care provider say (you/s/he) had?

\_\_\_\_\_

REFUSED	7
DON'T KNOW	8

**D8e.** Did (you/s/he) **visit** an emergency room?

YES	1
NO	2 (D9a)
REFUSED	7 (D9a)
DON'T KNOW	8 (D9a)

**D8f.** How many times?

_____ #TIMES	
REFUSED	7
DON'T KNOW	8

**D8g.** Were you admitted to the hospital?

YES	1
NO	2 (D9a)
REFUSED	7 (D9a)
DON'T KNOW	8 (D9a)

**D8h.** How many days (were you/was s/he) hospitalized?

_____ # DAYS	
REFUSED	7
DON'T KNOW	8

**D8i.** (Were you /Was s/he) given intravenous fluids?

YES	1
NO	2
REFUSED	7
DON'T KNOW	8

**D9a.** Did (you/s/he) receive a prescription for an antibiotic or other drug for this (illness/condition)?

YES	1
NO	2 (D10a)
REFUSED	7 (D10a)
DON'T KNOW	8 (D10a)

**D9b.** About how much of your own or your household's money was spent altogether for these prescription medicines?

Amount \$ \_\_\_\_\_

Amount to nearest dollar

**D10a.** Did (you/s/he) use any over-the-counter medications, including things like special drinks, only because of this (illness/condition)?

YES	1
NO	2 (E1)
REFUSED	7 (E1)
DON'T KNOW	8 (E1)



**D10b.** About how much of your own or your household's money was spent altogether for over-the-counter medicines?

Amount \$ \_\_\_\_\_

Amount to nearest dollar

**EXIT STATEMENT**

IF THERE IS ANOTHER PERSON IN THE ENUMERATION WHO WAS MARKED AS HAVING ANY SYNDROME, GO BACK TO D1 FOR THAT PERSON AND ASK APPROPRIATE QUESTIONS FROM **D1** THROUGH **D10b**

OR ELSE, IF THERE IS NO OTHER PERSON IN THE ENUMERATION WHO NEEDS TO BE ASKED ABOUT, GO TO **E1**.

**E1.** Before today, were you aware that people could become ill by swimming at the beach?

- YES 1
- NO 2
- REFUSED 7
- DON'T KNOW 8

**E2.** After today, will you change the way you use the water at the beach? Or Will you change your recreational use of water/activities at the beach?

- YES 1
- NO 2
- REFUSED 7
- DON'T KNOW 8

(We might want to move this to the front. Might make more sense. Moving it may bias)

**Q1.** Did you or anyone in your household wade, swim, or play in the water on \_\_\_/\_\_\_/\_\_\_?

	YES	NO	RF	DK
Person 1.....	1	2	7	8
Person 2.....	1	2	7	8
Person 3.....	1	2	7	8
Person 4.....	1	2	7	8
Person 5.....	1	2	7	8
Person 6.....	1	2	7	8
Person 7.....	1	2	7	8
Person 8.....	1	2	7	8

**IF NO TO PERSON 1 THROUGH PERSON 8, GO TO Q20**

Person	1	2	3	4	5	6	7	8
	Y N RF DK	Y N RF DK	Y N RF DK	Y N RF DK	Y N RF DK	Y N RF DK	Y N RF DK	Y N RF DK
<b>Q1a.1.</b> Did {PERSON} immerse their body, not necessarily {PERSON's} head, in water today? .....	1 2 7 8	1 2 7 8	1 2 7 8	1 2 7 8	1 2 7 8	1 2 7 8	1 2 7 8	1 2 7 8
<b>Q1a.2.</b> Did {PERSON} put their face in water or submerge head in water today?.....	1 2 7 8	1 2 7 8	1 2 7 8	1 2 7 8	1 2 7 8	1 2 7 8	1 2 7 8	1 2 7 8

**CONTINUE**

Person	1	2	3	4	5	6	7	8
	Y N RF DK	Y N RF DK	Y N RF DK	Y N RF DK	Y N RF DK	Y N RF DK	Y N RF DK	Y N RF DK
<b>Q1a.3.</b> Did {Person} get water in the mouth today?	1 2 7 8	1 2 7 8	1 2 7 8	1 2 7 8	1 2 7 8	1 2 7 8	1 2 7 8	1 2 7 8

**IF NO TO THE ABOVE QUESTION, GO TO QUESTION Q2..**

**Q1a.4.** Did {PERSON} gag or cough after getting water in their mouth?

	YES	NO	RF	DK
Person 1.....	1.....	2.....	7.....	8.....
Person 2.....	1.....	2.....	7.....	8.....
Person 3.....	1.....	2.....	7.....	8.....
Person 4.....	1.....	2.....	7.....	8.....
Person 5.....	1.....	2.....	7.....	8.....
Person 6.....	1.....	2.....	7.....	8.....
Person 7.....	1.....	2.....	7.....	8.....
Person 8.....	1.....	2.....	7.....	8.....

**IF NO TO PERSON 1 THROUGH PERSON 8, GO TO Q16d**

Q1a.5. Did {PERSON} swallow the water?

	YES	NO	RF	DK
Person 1.....	1.....	2.....	7.....	8.....
Person 2.....	1.....	2.....	7.....	8.....
Person 3.....	1.....	2.....	7.....	8.....
Person 4.....	1.....	2.....	7.....	8.....
Person 5.....	1.....	2.....	7.....	8.....
Person 6.....	1.....	2.....	7.....	8.....
Person 7.....	1.....	2.....	7.....	8.....
Person 8.....	1.....	2.....	7.....	8.....

**Q2.** What total time did {PERSON} stay in the water? We are only interested in time actually in the water, not the total time at the beach. **(CIRCLE TIME UNITS)**

**RF DK**

Person 1 .....	_____ MINUTES	_____.	__ HOURS	7	8
Person 2 .....	_____ MINUTES	_____.	__ HOURS	7	8
Person 3 .....	_____ MINUTES	_____.	__ HOURS	7	8
Person 4 .....	_____ MINUTES	_____.	__ HOURS	7	8
Person 5 .....	_____ MINUTES	_____.	__ HOURS	7	8
Person 6 .....	_____ MINUTES	_____.	__ HOURS	7	8
Person 7 .....	_____ MINUTES	_____.	__ HOURS	7	8
Person 8 .....	_____ MINUTES	_____.	__ HOURS	7	8

This completes our telephone interview and your participation. I'd like to verify your address so we can mail a check for \$25 to {BEACH RESPONDENT}. (VERIFY ADDRESS ON CALL SHEET.) You will receive your check in 30 days and thank you for your participation in this study. Thank you for taking the time to talk with me. Goodbye.

**IF RESP DOESN'T HAVE BROCHURE:**

You can call 1-888-422-3072, from 8 am to 4:30 pm, Monday through Friday, Eastern time; mention you are calling about the NEEAR study.

Website: NEEAR Water Study

You can also e-mail [neear\\_water\\_study@epa.gov](mailto:neear_water_study@epa.gov).

# **QAPP 2**

## **Appendix 4A**

### **Eligibility Screener**

**University of Illinois, Chicago**  
**CHEERS Study**  
**Eligibility Screener & Refusal Tally sheet 2008**

Hello. My name is *[YOUR NAME]* and I am part of the CHEERS field team. I'm going to ask you a few questions to see if you are eligible to be part of our research study.

1. What outdoor activity will you be doing today: \_\_\_\_\_?  
Are you also going to **SWIM, BOOGIE BOARD, WATER/JET SKI or GO TUBING.**  
**If "YES", terminate recruiting. NO PRIMARY CONTACT ACTIVITY.**
  
2. Have you (or your child) enrolled in the CHEERS study in the past 21 days?  
Yes (terminate recruiting)                      No
  
3. Have you (or you child) participated in any water recreational activity (such as swimming, skiing, kayaking, fishing, boating etc) at a lake, river or beach in the past 48 hours? **SWIMMING IN A POOL IS OK.**  
Yes (terminate recruiting)                      No

***DOG WALKERS- If they waded in the water with their dogs, they are ineligible.***

4. Is it OK for us to contact you by **phone 3 times over the next three weeks** and ask you questions about your health?  
Yes    No (terminate recruiting)
  
5. **WATER-RECREATORS-** Will you be back by (*tell them what time we plan on wrapping up for the day*) today?

***If "NO"-*** Let them know it is important that we complete this survey before we leave this location today. If participant cannot return to complete the survey- they are ***"NOT ELIGIBLE"***.

***If "NOT ELIGIBLE".*** I'm sorry, but you will not be eligible for enrolling in the study now. Please look for the CHEERS team in the future and you may be able to enroll then.

***If ELIGIBLE: Proceed to consent process.***

***Note: Participants are eligible even if they live outside the Chicago area or Illinois.***

STARTS **APPROVAL** EXPIRES

JUN 21 2008    JUN 20 2009

UNIVERSITY OF ILLINOIS AT CHICAGO  
INSTITUTIONAL REVIEW BOARD

# **QAPP 2**

## **Appendix 4B**

### **Refusal Tally Sheet**

## Refusal Tally Sheet

Date \_\_\_\_\_ Researcher \_\_\_\_\_ Location \_\_\_\_\_

Time	No: Adults		No: Child		Reason for Ineligibility *	Reason for refusal*
	M	F	M	F		
					Lang NP CE NPh IWA RWC RL Non-US	NT NR Concerns
					Lang NP CE NPh IWA RWC RL Non-US	NT NR Concerns
					Lang NP CE NPh IWA RWC RL Non-US	NT NR Concerns
					Lang NP CE NPh IWA RWC RL Non-US	NT NR Concerns
					Lang NP CE NPh IWA RWC RL Non-US	NT NR Concerns
					Lang NP CE NPh IWA RWC RL Non-US	NT NR Concerns
					Lang NP CE NPh IWA RWC RL Non-US	NT NR Concerns
					Lang NP CE NPh IWA RWC RL Non-US	NT NR Concerns
					Lang NP CE NPh IWA RWC RL Non-US	NT NR Concerns
					Lang NP CE NPh IWA RWC RL Non-US	NT NR Concerns
					Lang NP CE NPh IWA RWC RL Non-US	NT NR Concerns
					Lang NP CE NPh IWA RWC RL Non-US	NT NR Concerns
					Lang NP CE NPh IWA RWC RL Non-US	NT NR Concerns
					Lang NP CE NPh IWA RWC RL Non-US	NT NR Concerns
					Lang NP CE NPh IWA RWC RL Non-US	NT NR Concerns
					Lang NP CE NPh IWA RWC RL Non-US	NT NR Concerns
					Lang NP CE NPh IWA RWC RL Non-US	NT NR Concerns
					Lang NP CE NPh IWA RWC RL Non-US	NT NR Concerns
					Lang NP CE NPh IWA RWC RL Non-US	NT NR Concerns
					Lang NP CE NPh IWA RWC RL Non-US	NT NR Concerns
					Lang NP CE NPh IWA RWC RL Non-US	NT NR Concerns
					Lang NP CE NPh IWA RWC RL Non-US	NT NR Concerns
					Lang NP CE NPh IWA RWC RL Non-US	NT NR Concerns
					Lang NP CE NPh IWA RWC RL Non-US	NT NR Concerns
					Lang NP CE NPh IWA RWC RL Non-US	NT NR Concerns
					Lang NP CE NPh IWA RWC RL Non-US	NT NR Concerns
					Lang NP CE NPh IWA RWC RL Non-US	NT NR Concerns
					Lang NP CE NPh IWA RWC RL Non-US	NT NR Concerns
					Lang NP CE NPh IWA RWC RL Non-US	NT NR Concerns
					Lang NP CE NPh IWA RWC RL Non-US	NT NR Concerns
					Lang NP CE NPh IWA RWC RL Non-US	NT NR Concerns
					Lang NP CE NPh IWA RWC RL Non-US	NT NR Concerns
					Lang NP CE NPh IWA RWC RL Non-US	NT NR Concerns
					Lang NP CE NPh IWA RWC RL Non-US	NT NR Concerns
					Lang NP CE NPh IWA RWC RL Non-US	NT NR Concerns
					Lang NP CE NPh IWA RWC RL Non-US	NT NR Concerns
					Lang NP CE NPh IWA RWC RL Non-US	NT NR Concerns
					Lang NP CE NPh IWA RWC RL Non-US	NT NR Concerns
					Lang NP CE NPh IWA RWC RL Non-US	NT NR Concerns
					Lang NP CE NPh IWA RWC RL Non-US	NT NR Concerns

\*Please circle or more of the following options:

No time =NT	Confidentiality concerns = Concerns
Language barrier = Lang	Ineligible Water Activity= IWA
No Reason =NR	Recent Water Contact=RWC
No Parent= NP	Return Late= RL
Currently Enrolled= CE	Lives out of US= Non-US
No Phone = NPh	

# CHEERS QAPP 2

## APPENDIX 6: FIELD SURVEY B



CHEERS Part B

PB\_S2loc  
Location:

- 1 = River
  - 2 = Lake
  - DON'T KNOW
  - REFUSAL
- 

IF RIVER:

PB\_S2  
Enter River Location:

- 1 = Skokie Rowing Center
  - 2 = Clark Park
  - 3 = River/Honan Park
  - 4 = North Avenue
  - 5 = Alsip
  - 6 = Worth
  - 7 = Little Calumet River
  - 8 = 28 Street
  - 9 = OTHER (SPECIFY)
  - DON'T KNOW
  - REFUSAL
- 

IF LAKE:

PB\_S3  
Enter General Area Waterways Location:

- 1 = Leone Beach
  - 2 = Montrose Harbor
  - 3 = Wilson Beach
  - 4 = Belmont Harbor
  - 5 = Diversey Harbor
  - 6 = Jackson Park Harbor
  - 7 = Skokie Lagoons
  - 8 = Des Plaines River
  - 9 = Kankakee River
  - 10 = Fox River
  - 11 = OTHER (SPECIFY)
  - DON'T KNOW
  - REFUSAL
-

PB\_Intro

"Thank you for returning to complete the survey. We will have your t-shirt and gift-card ready for you after we complete the survey. May I have your name so that we can link it to your previous answers?"

-----  
PB\_Q1First

"What is your first name?"

-----  
PB\_Q1Last

"What is your last name?"

-----  
PB\_Q9

"Did you engage in any water recreational activities at the <location> today?":

- 1 = Yes
- 2 = No → SKIP TO Q12 SERIES
- DON'T KNOW → SKIP TO Q12 SERIES
- REFUSAL → SKIP TO Q12 SERIES

-----  
IF YES TO PB\_Q9:

PB\_Q9a

"What water recreational activities did you engage in while at the <location> today?"

Check All That Apply. If 'NONE' be sure no others are checked.

- 1 = Boating
- 2 = Canoeing
- 3 = Kayaking
- 4 = Rowing
- 5 = Rafting
- 6 = Fishing on a boat
- 7 = Fishing at the pier, shore or dock
- 8 = None of the above
- DON'T KNOW
- REFUSAL

-----  
PB\_Q9b

"Did you (read activities from list) also while at the <location> today?"

Check All That Apply.

- 1 = Jet ski?
- 2 = Water ski?
- 3 = Go tubing?

- 4 = Boogie board?
- 5 = Use a waverunner?
- 6 = Swim?
- 7 = Go sailing?
- 8 = None of the above?
- DON'T KNOW
- REFUSAL

---

IF PB\_Q9b RESPONSE IS "SWIM":

PB\_Q9c

"You said you swam today. Was it accidental or intentional?":

- 1 = Accidental
- 2 = Intentional
- DON'T KNOW
- REFUSAL

---

IF PB\_Q9b RESPONSE IS "INTENTIONAL"

INEL

"Thank you for participating in the CHEERS study.  
We will not be calling you for the follow-up telephone survey."

(INTERVIEWER): Be sure they receive their t-shirt and \$15 gift card.

---

ASK Q10 SERIES FOR EACH ACTIVITY:

PB\_Q10SAIL.i\_H

"For how long did you <FILL ACTIVITY>?"

Enter in hours and minutes.

Enter a number between 0 and 18 for hours.  
Enter a number between 0 and 59 for minutes

---

ASK ONLY FOR BOAT ACTIVITIES:

PB\_Q10SAIL.ii

"Where did you launch with your <FILL ACTIVITY>?"

- 1 = Shore
- 2 = Pier or dock
- 3 = Boat launch

DON'T KNOW  
REFUSAL

---

ASK ONLY FOR BOAT ACTIVITIES:

PB\_Q10SAIL.iii

"Where did you exit with your <FILL ACTIVITY>?"

1 = Shore  
2 = Pier or dock  
3 = Boat launch  
DON'T KNOW  
REFUSAL

---

ASK ONLY FOR BOAT ACTIVITIES:

PB\_Q10SAIL.iv

"Did you travel upstream or downstream?"

1 = Upstream  
2 = Downstream  
3 = Both  
DON'T KNOW  
REFUSAL

---

PB\_Q10SAIL.v

"Did any part of your body get wet at all today?"

1 = Yes  
2 = No → SKIP TO PB\_Q10SAIL.vii  
DON'T KNOW → SKIP TO PB\_Q10SAIL.vii  
REFUSAL → SKIP TO PB\_Q10SAIL.vii

---

IF YES TO PB\_10SAIL.v:

PB\_Q10SAIL.vi

"How wet did you get? Would you say..."

1 = Sprinkle or few drops,  
2 = Splashed,  
3 = Drenched, or,  
4 = Submerged?  
DON'T KNOW

REFUSAL

---

PB\_Q10SAIL.vi\_feet

"How wet did your feet or legs get? Would you say..."

1 = Sprinkle or few drops,

2 = Splashed,

3 = Drenched,

4 = Submerged, or,

5 = Not wet at all?

DON'T KNOW

REFUSAL

---

PB\_Q10SAIL.vi\_hands

"How wet did your hands or arms get? Would you say...":

1 = Sprinkle or few drops,

2 = Splashed,

3 = Drenched,

4 = Submerged, or,

5 = Not wet at all?

DON'T KNOW

REFUSAL

---

PB\_Q10SAIL.vi\_torso

"How wet did your torso (that is your stomach or back) get? Would you say...":

1 = Sprinkle or few drops,

2 = Splashed,

3 = Drenched,

4 = Submerged, or,

5 = Not wet at all?

DON'T KNOW

REFUSAL

---

PB\_Q10SAIL.vii

"Did your face or head get wet?":

1 = Yes

2 = No → SKIP TO PB\_Q10SAIL.xvii

DON'T KNOW → SKIP TO PB\_Q10SAIL.xvii

REFUSAL → SKIP TO PB\_Q10SAIL.xvii

---

IF YES TO PB\_Q10SAIL.vii:

PB\_Q10SAIL.viii

"How wet did your face or head get? Would you say..."

- 1 = Sprinkle or few drops,
- 2 = Splashed,
- 3 = Drenched, or,
- 4 = Submerged?
- DON'T KNOW
- REFUSAL

---

PB\_Q10SAIL.ix

"Did you get any water in your mouth today?"

- 1 = Yes
- 2 = No
- DON'T KNOW
- REFUSAL

---

PB\_Q10SAIL.xv

"Did you swallow any water while <FILL ACTIVITY> today?"

- 1 = Yes
- 2 = No → SKIP TO
- DON'T KNOW
- REFUSAL

---

IF YES TO PB\_Q10SAIL.xv:

PB\_Q10SAIL.xvi

"Would you say it was..."

(PROBE): Your best estimate is fine."

- 1 = A drop or two,
- 2 = A teaspoon, or,
- 3 = One or more mouthfuls?
- DON'T KNOW
- REFUSAL

---

ASK ONLY FOR BOAT ACTIVITIES:

PB\_Q10SAIL.xvii

"Did you get wet while launching the <FILL ACTIVITY>?"

- 1 = Yes
- 2 = No
- DON'T KNOW
- REFUSAL

---

ASK ONLY FOR BOAT ACTIVITIES:

PB\_Q10SAIL.xviii

"Did your <FILL ACTIVITY> flip over or capsize today?"

- 1 = Yes
- 2 = No → SKIP TO PB\_Q10SAIL.xxiii\_A
- DON'T KNOW → SKIP TO PB\_Q10SAIL.xxiii\_A
- REFUSAL → SKIP TO PB\_Q10SAIL.xxiii\_A

---

IF YES TO PB\_Q10SAIL.xviii:

PB\_Q10SAIL.xix

"How many times?"

- 1 = One
- 2 = Two
- 3 = More than twice
- DON'T KNOW
- REFUSAL

---

IF YES TO PB\_Q10SAIL.xviii:

PB\_Q10SAIL.xix\_H

"How long did you stay in the water after capsizing?"

Enter in hours and minutes.

Enter a number between 0 and 18 for hours.

Enter a number between 0 and 59 for minutes.

---

PB\_Q10SAIL.xxiii\_A

"Did you wade into the water or stand in the water while <FILL ACTIVITY> today?"

- 1 = Yes
- 2 = No → SKIP TO PB\_Q10SAIL.Rubeyes

DON'T KNOW → SKIP TO PB\_Q10SAIL.Rubeyes  
REFUSAL → SKIP TO PB\_Q10SAIL.Rubeyes

---

IF YES TO PB\_Q10SAIL.xxiii\_A:

PB\_Q10SAIL.xxiii\_B

"Did you wear waders or hip boots?"

1 = Yes

2 = No

DON'T KNOW

REFUSAL

---

IF YES TO PB\_Q10SAIL.xxiii\_A:

PB\_Q10SAIL.xxiii\_CH

"How long did you stay in the water?"

Enter in hours and minutes.

Enter a number between 0 and 18 for hours.

Enter a number between 0 and 59 for minutes.

---

PB\_Q10SAIL.Rubeyes

"Did you rub your eyes while <FILL ACTIVITY> today?"

1 = Yes

2 = No

DON'T KNOW

REFUSAL

---

PB\_Q10SAIL.xxiv

"You said you were boating. Was it on a power boat?"

1 = Yes

2 = No

DON'T KNOW

REFUSAL

---

IF YES TO PB\_Q10SAIL.xxiv:

PB\_Q10SAIL.xxv



"How long is your boat?"

Enter a number in feet from 1 to 100.

(PROBE): Approximately how many feet?"

-----  
ASK ONLY FOR BOAT ACTIVITIES:

PB\_Q10SAIL.xxvi

"How many people, not including yourself, were on the boat with you today?"

Enter a number from 0 to 97.

-----  
ASK IF RESPONSE TO PB\_Q10SAIL.xxvi IS MORE THAN "1":

PB\_Q10SAIL.xxvii

"How many of these people, not including yourself, are enrolled in the CHEERS study?"

Enter a number from 0 to 97.

-----  
ASK FOR EACH PERSON:

PB\_Q10SAIL.Roster.Person[01].Q1cName

"What is the full name of the (first/next) person who was on the boat with you, who is also enrolled in the CHEERS study?":

-----  
ASK FOR EACH PERSON:

PB\_Q10SAIL.Roster.Person[01].Q1cGender

"What is their gender?"

1 = Male  
2 = Female  
DON'T KNOW  
REFUSAL

-----  
ASK ONLY FOR FISHING ACTIVITIES:

PB\_Q10SAIL.xxviii

"How many fish did you catch while <FILL ACTIVITY> today?"

-----  
ASK ONLY FOR FISHING ACTIVITIES:

PB\_Q10SAIL.xxvix

"What kind of bait did you use <FILL ACTIVITY> today? Did you use..."

Check All That Apply.

- 1 = Live bait such as worms or minnows?,
- 2 = Artificial lures?,
- 3 = Natural lures such as corn, fish eggs or meat?,
- 4 = Some other type of bait? (SPECIFY)
- DON'T KNOW
- REFUSAL

---

ASK ONLY FOR FISHING ACTIVITIES:

PB\_Q10SAIL.xxx

"Do you plan on eating any of the fish you caught today?"

- 1 = Yes
- 2 = No
- DON'T KNOW
- REFUSAL

---

PB\_Q11.a

"Did you eat during or after your activities at the <LOCATION>?"

(NOTE): Only record any eating before they left the location.

- 1 = Yes
- 2 = No → SKIP TO PB\_Q11.d
- DON'T KNOW → SKIP TO PB\_Q11.d
- REFUSAL → SKIP TO PB\_Q11.d

---

IF YES TO PB\_Q11a:

PB\_Q11.b

"Did you clean your hands before eating?"

- 1 = Yes
- 2 = No → SKIP TO PB\_Q11.d
- DON'T KNOW → SKIP TO PB\_Q11.d
- REFUSAL → SKIP TO PB\_Q11.d

---

IF YES TO PB\_Q11b:

PB\_Q11.c

"Did you use..."

Read All Choices. Check All That Apply.

(NOTE): <LOCATION> water doesn't count.

- 1 = Soap,
- 2 = A hand sanitizer,
- 3 = Hand wipes, or,
- 4 = Just rinse your hands?
- 5 = Other (SPECIFY)
- DON'T KNOW
- REFUSAL

---

PB\_Q11.d

"Did you drink anything during or after your activities at the <LOCATION> today?"

(NOTE): Only record any drinking before they left the location.

- 1 = Yes
- 2 = No → SKIP TO CE\_1Intro
- DON'T KNOW → SKIP TO CE\_1Intro
- REFUSAL → SKIP TO CE\_1Intro

---

IF YES TO PB\_Q11d:

PB\_Q11.e

"Did you clean your hands before drinking?"

- 1 = Yes
- 2 = Sometimes
- 3 = No → SKIP TO PB\_Q11g
- DON'T KNOW → SKIP TO PB\_Q11g
- REFUSAL → SKIP TO PB\_Q11g

---

IF YES OR SOMETIMES TO PB\_Q11e:

PB\_Q11.f

"Did you use..."

Read All Choices. Check All That Apply.

(NOTE): <LOCATION> water doesn't count."

- 1 = Soap,
- 2 = A hand sanitizer,
- 3 = Hand wipes, or,

4 = Just rinse your hands?  
5 = Other (SPECIFY)  
DON'T KNOW  
REFUSAL

---

IF YES TO PB\_Q11d:

PB\_Q11.g

"How many ounces did you drink at the <LOCATION> today?"

(PROBE): Your best estimate is fine.

Use Visual Aids As Appropriate:

Can = 12 ounces

Small bottle = 8 ounces

Regular bottle = 16 ounces

Or Check their water bottle.

Enter a number from 1 to 500.

---

ASK THE Q12 SERIES AND Q13 SERIES FOR RESPONDENTS WHO DID NOT DO ANY WATER REC ACTIVITIES TODAY:

PB\_Q12[

"What activity did you participate in today? Did you..."

Read All Categories. Check All That Apply.":

1 = Roller blade?,

2 = Run?,

3 = Walk?,

4 = Cycle?,

5 = Golf?,

6 = Play baseball?,

7 = Play softball?,

8 = Play soccer?,

9 = Play tennis?,

10 = Walk your dog?,

11 = Do any other activity? (SPECIFY)

DON'T KNOW

REFUSAL

---

PB\_Q13

"Did you at any point in time today come in contact with the <LOCATION> water?"

1 = Yes

2 = No → SKIP TO CE\_1Intro  
DON'T KNOW → SKIP TO CE\_1Intro  
REFUSAL → SKIP TO CE\_1Intro

---

PB\_Q13a

"Did any part of your body get wet at all today?"

1 = Yes  
2 = No → SKIP TO CE\_1Intro  
DON'T KNOW → SKIP TO CE\_1Intro  
REFUSAL → SKIP TO CE\_1Intro

---

PB\_Q13b

"Did your face or head get wet?"

1 = Yes  
2 = No → SKIP TO CE\_1Intro  
DON'T KNOW → SKIP TO CE\_1Intro  
REFUSAL → SKIP TO CE\_1Intro

---

IF YES TO PB\_Q13b:

PB\_Q13c

"How wet did your face or head get?"

1 = Sprinkle or few drops,  
2 = Splashed,  
3 = Drenched, or,  
4 = Submerged?  
DON'T KNOW  
REFUSAL

---

PB\_Q13d

"Did you get any <LOCATION> water in your mouth today?"

1 = Yes  
2 = No  
DON'T KNOW  
REFUSAL

---

PB\_Q13e

"Did you swallow any <LOCATION> water today?"

1 = Yes

2 = No → SKIP TO CE\_1Intro

DON'T KNOW → SKIP TO CE\_1Intro

REFUSAL → SKIP TO CE\_1Intro

---

IF YES TO Q13e:

PB\_Q13f

"Would you say it was..."

(IF NECESSARY): Your best estimate is fine."

1 = A drop or two,

2 = A teaspoon, or,

3 = One or more mouthfuls?

DON'T KNOW

REFUSAL

---

CE\_1Intro

"Now I am going to ask you a few questions about your current health status.

---

CE\_1a1

"Do you have any ongoing stomach or intestinal problems, otherwise known as gastrointestinal problems?"

1 = Yes

2 = No → SKIP TO CE\_1b

DON'T KNOW → SKIP TO CE\_1b

REFUSAL → SKIP TO CE\_1b

---

IF YES TO CE\_1a1:

CE\_1a2

"Which of the following do you have? Do you have..."

Check All That Apply.

1 = Crohn's disease?,

2 = Inflammatory bowel disease?,

3 = Irritable bowel syndrome?,

4 = Ulcers?,  
5 = Gastritis?,  
6 = Acid Reflux?,  
7 = Lactose intolerance?,  
8 = OTHER (SPECIFY)  
DON'T KNOW  
REFUSAL

---

CE\_1b

"Do you have any ongoing respiratory problems such as asthma, bronchitis or emphysema?":

1 = Yes  
2 = No  
DON'T KNOW  
REFUSAL

---

CE\_1c

"Do you have diabetes?"

1 = Yes  
2 = No  
DON'T KNOW  
REFUSAL

---

CE\_1d

"In the past 7 days, have you taken oral antibiotics?"

1 = Yes  
2 = No  
DON'T KNOW  
REFUSAL

---

CE\_1e

"Do you have any condition that makes you more likely to get infections?"

1 = Yes  
2 = No  
DON'T KNOW  
REFUSAL

---

CE\_1f

"In the past 48 hours, have you taken any antacids such as Tums, Roloids and Mylanta?"

(NOTE): Also includes Pepsid AC, Zantac, Prilosec."

1 = Yes

2 = No

DON'T KNOW

REFUSAL

---

CE\_2

"On average, how many bowel movements do you have in a day?"

(PROBE): By bowel movements we mean pooping.

0) Less than one

1) One

2) Two

3) Three or more

DON'T KNOW

REFUSAL

---

CE\_2a

"Do you wear contact lenses?"

1 = Yes

2 = No

3 = Sometimes

DON'T KNOW

REFUSAL

---

CE\_3a

"Now I am going to ask you a few questions about how you are feeling today.

Are you currently experiencing any of the following symptoms?"

Abdominal cramps or stomach ache?

1 = Yes

2 = No

DON'T KNOW

REFUSAL

---

CE\_3b



"Diarrhea or loose bowels?"

1 = Yes  
2 = No  
DON'T KNOW  
REFUSAL

---

CE\_3c

"Nausea?"

1 = Yes  
2 = No  
DON'T KNOW  
REFUSAL

---

CE\_3d

"Vomiting?"

1 = Yes  
2 = No  
DON'T KNOW  
REFUSAL

---

CE\_3e

"Fever?"

1 = Yes  
2 = No  
DON'T KNOW  
REFUSAL

---

CE\_3f

"Headache?"

1 = Yes  
2 = No  
DON'T KNOW  
REFUSAL

---

CE\_3g

"Sore throat?"

1 = Yes  
2 = No  
DON'T KNOW  
REFUSAL

---

CE\_3h

"A bad or persistent cough?

1 = Yes  
2 = No  
DON'T KNOW  
REFUSAL

---

CE\_3i

"A cold, or a runny or stuffy nose?

1 = Yes  
2 = No  
DON'T KNOW  
REFUSAL

---

CE\_3j

"Ear ache or ear infection?

1 = Yes  
2 = No  
DON'T KNOW  
REFUSAL

---

CE\_3k

"Eye irritation?

1 = Yes  
2 = No  
DON'T KNOW  
REFUSAL

---

CE\_3l

"Drainage or crusting in your eyes?

1 = Yes  
2 = No  
DON'T KNOW  
REFUSAL

---

CE\_3cut

"Any areas on your skin where there are cuts?"

1 = Yes  
2 = No  
DON'T KNOW  
REFUSAL

---

CE\_3bug

"Any areas on your skin where there are bug bites?"

1 = Yes  
2 = No  
DON'T KNOW  
REFUSAL

---

CE\_3m

"Any areas on your skin that are sore or draining?"

1 = Yes  
2 = No  
DON'T KNOW  
REFUSAL

---

CE\_3n

"Rash or itchy skin?"

1 = Yes  
2 = No  
DON'T KNOW  
REFUSAL

---

CE\_cut[

"Where are the cuts located? Check All That Apply."

1 = RIGHT SIDE, HEAD/FACE,

2 = RIGHT SIDE, NECK,  
3 = RIGHT SIDE, UPPER ARM,  
4 = RIGHT SIDE, ELBOW,  
5 = RIGHT SIDE, FORE ARM,  
6 = RIGHT SIDE, HAND,  
7 = RIGHT SIDE, FINGERS,  
8 = RIGHT SIDE, THIGH,  
9 = RIGHT SIDE, KNEE,  
10 = RIGHT SIDE, LOWER LEG,  
11 = RIGHT SIDE, ANKLE/FOOT,  
12 = RIGHT SIDE, TOES,  
13 = RIGHT SIDE, ABDOMEN,  
14 = RIGHT SIDE, CHEST,  
15 = RIGHT SIDE, BACK,  
16 = RIGHT SIDE, (SPECIFY),  
17 = LEFT SIDE, HEAD/FACE,  
18 = LEFT SIDE, NECK,  
19 = LEFT SIDE, UPPER ARM,  
20 = LEFT SIDE, ELBOW,  
21 = LEFT SIDE, FORE ARM,  
22 = LEFT SIDE, HAND,  
23 = LEFT SIDE, FINGERS,  
24 = LEFT SIDE, THIGH,  
25 = RIGHT SIDE, KNEE,  
26 = LEFT SIDE, LOWER LEG,  
27 = LEFT SIDE, ANKLE/FOOT,  
28 = LEFT SIDE, TOES,  
29 = LEFT SIDE, ABDOMEN,  
30 = LEFT SIDE, CHEST,  
31 = LEFT SIDE, BACK,  
32 = LEFT SIDE, (SPECIFY)  
DON'T KNOW  
REFUSAL

-----  
IF CUT ON RIGHT SIDE AT OTHER LOCATION:

CE\_cutRO\_text

"Where else on your right side did you cut yourself?"

-----  
IF CUT ON LEFT SIDE AT OTHER LOCATION:

CE\_cutLO\_text

"Where else on your left side did you cut yourself?"

-----  
CE\_bug[

"Where are the bug bites or cuts located? Check All That Apply."

- 1 = RIGHT SIDE, HEAD/FACE,
- 2 = RIGHT SIDE, NECK,
- 3 = RIGHT SIDE, UPPER ARM,
- 4 = RIGHT SIDE, ELBOW,
- 5 = RIGHT SIDE, FORE ARM,
- 6 = RIGHT SIDE, HAND,
- 7 = RIGHT SIDE, FINGERS,
- 8 = RIGHT SIDE, THIGH,
- 9 = RIGHT SIDE, KNEE,
- 10 = RIGHT SIDE, LOWER LEG,
- 11 = RIGHT SIDE, ANKLE/FOOT,
- 12 = RIGHT SIDE, TOES,
- 13 = RIGHT SIDE, ABDOMEN,
- 14 = RIGHT SIDE, CHEST,
- 15 = RIGHT SIDE, BACK,
- 16 = RIGHT SIDE, (SPECIFY),
- 17 = LEFT SIDE, HEAD/FACE,
- 18 = LEFT SIDE, NECK,
- 19 = LEFT SIDE, UPPER ARM,
- 20 = LEFT SIDE, ELBOW,
- 21 = LEFT SIDE, FORE ARM,
- 22 = LEFT SIDE, HAND,
- 23 = LEFT SIDE, FINGERS,
- 24 = LEFT SIDE, THIGH,
- 25 = RIGHT SIDE, KNEE,
- 26 = LEFT SIDE, LOWER LEG,
- 27 = LEFT SIDE, ANKLE/FOOT,
- 28 = LEFT SIDE, TOES,
- 29 = LEFT SIDE, ABDOMEN,
- 30 = LEFT SIDE, CHEST,
- 31 = LEFT SIDE, BACK,
- 32 = LEFT SIDE, (SPECIFY)
- DON'T KNOW
- REFUSAL

-----  
IF BUG BITES ON RIGHT SIDE ON OTHER LOCATION:

CE\_bugRO\_text

"Where else on your right side did you have bug bites?"

-----  
IF BUG BITES ON LEFT SIDE ON OTHER LOCATION:

CE\_bugLO\_text

"Where else on your left side did you have bug bites?"

-----  
CE\_sore[

"Where are the sores or draining skin located? Check All That Apply."

- 1 = RIGHT SIDE, HEAD/FACE,
- 2 = RIGHT SIDE, NECK,
- 3 = RIGHT SIDE, UPPER ARM,
- 4 = RIGHT SIDE, ELBOW,
- 5 = RIGHT SIDE, FORE ARM,
- 6 = RIGHT SIDE, HAND,
- 7 = RIGHT SIDE, FINGERS,
- 8 = RIGHT SIDE, THIGH,
- 9 = RIGHT SIDE, KNEE,
- 10 = RIGHT SIDE, LOWER LEG,
- 11 = RIGHT SIDE, ANKLE/FOOT,
- 12 = RIGHT SIDE, TOES,
- 13 = RIGHT SIDE, ABDOMEN,
- 14 = RIGHT SIDE, CHEST,
- 15 = RIGHT SIDE, BACK,
- 16 = RIGHT SIDE, OTHER (SPECIFY),
- 17 = LEFT SIDE, HEAD/FACE,
- 18 = LEFT SIDE, NECK,
- 19 = LEFT SIDE, UPPER ARM,
- 20 = LEFT SIDE, ELBOW,
- 21 = LEFT SIDE, FORE ARM,
- 22 = LEFT SIDE, HAND,
- 23 = LEFT SIDE, FINGERS,
- 24 = LEFT SIDE, THIGH,
- 25 = LEFT SIDE, KNEE,
- 26 = LEFT SIDE, LOWER LEG,
- 27 = LEFT SIDE, ANKLE/FOOT,
- 28 = LEFT SIDE, TOES,
- 29 = LEFT SIDE, ABDOMEN,
- 30 = LEFT SIDE, CHEST,
- 31 = LEFT SIDE, BACK,
- 32 = LEFT SIDE, OTHER (SPECIFY)
- DON'T KNOW
- REFUSAL

-----  
IF SORES / DRAINING SIDE ON RIGHT SIDE ON OTHER LOCATION:

CE\_soreRO\_text

"List other sites on right side where R has sores or draining skin."

-----  
IF SORES / DRAINING SIDE ON LEFT SIDE ON OTHER LOCATION:

CE\_soreLO\_text

"List other sites on left side where R has sores or draining skin."

-----  
CE\_rash[

"Where is the rash located? Check All That Apply."

- 1 = RIGHT SIDE, HEAD/FACE,
- 2 = RIGHT SIDE, NECK,
- 3 = RIGHT SIDE, UPPER ARM,
- 4 = RIGHT SIDE, ELBOW,
- 5 = RIGHT SIDE, FORE ARM,
- 6 = RIGHT SIDE, HAND,
- 7 = RIGHT SIDE, FINGERS,
- 8 = RIGHT SIDE, THIGH,
- 9 = RIGHT SIDE, KNEE,
- 10 = RIGHT SIDE, LOWER LEG,
- 11 = RIGHT SIDE, ANKLE/FOOT,
- 12 = RIGHT SIDE, TOES,
- 13 = RIGHT SIDE, ABDOMEN,
- 14 = RIGHT SIDE, CHEST,
- 15 = RIGHT SIDE, BACK,
- 16 = RIGHT SIDE, (SPECIFY),
- 17 = LEFT SIDE, HEAD/FACE,
- 18 = LEFT SIDE, NECK,
- 19 = LEFT SIDE, UPPER ARM,
- 20 = LEFT SIDE, ELBOW,
- 21 = LEFT SIDE, FORE ARM,
- 22 = LEFT SIDE, HAND,
- 23 = LEFT SIDE, FINGERS,
- 24 = LEFT SIDE, THIGH,
- 25 = RIGHT SIDE, KNEE,
- 26 = LEFT SIDE, LOWER LEG,
- 27 = LEFT SIDE, ANKLE/FOOT,
- 28 = LEFT SIDE, TOES,
- 29 = LEFT SIDE, ABDOMEN,
- 30 = LEFT SIDE, CHEST,
- 31 = LEFT SIDE, BACK,
- 32 = LEFT SIDE, (SPECIFY),
- DON'T KNOW
- REFUSAL

-----  
IF RASH ON RIGHT SIDE ON OTHER LOCATION:

CE\_rashRO\_text

"Where else on your right side do you have a rash?"

-----  
IF RASH ON LEFT SIDE ON OTHER LOCATION:

CE\_rashLO\_text

"Where else on your left side do you have a rash?"

-----  
PB\_Q15

"Are you currently sunburned?"

1 = Yes

2 = No

DON'T KNOW

REFUSAL

-----  
PB\_Q2a

"In the past 72 hours have you come in contact with someone who had vomiting or diarrhea?"

1 = Yes

2 = No → SKIP TO PB\_Q2b

DON'T KNOW No → SKIP TO PB\_Q2b

REFUSAL No → SKIP TO PB\_Q2b

-----  
IF YES TO PB\_Q2a:

PB\_Q2a1

"Were any of those contacts with people who live with you, such as family members or roommates?"

1 = Yes

2 = No

DON'T KNOW

REFUSAL

-----  
PB\_Q2b

"In the past 72 hours have you come in contact with someone who had a cold, cough or sore throat?"

1 = Yes

2 = No No → SKIP TO PB\_Q2c

DON'T KNOW No → SKIP TO PB\_Q2c

REFUSAL No → SKIP TO PB\_Q2c



-----  
IF YES TO PB\_Q2b:

PB\_Q2b1

"Were any of those contacts with people who live with you, such as family members or roommates?":

(

1 = Yes

2 = No

DON'T KNOW

REFUSAL

-----  
PB\_Q2c

"In the past 72 hours have you come in contact with someone who had an eye infection?"

1 = Yes

2 = No

DON'T KNOW

REFUSAL

-----  
PB\_Q3a

"In the last 48 hours have you touched a cat or dog?"

1 = Yes

2 = No

DON'T KNOW

REFUSAL

-----  
PB\_Q3b

"In the last 48 hours have you touched any animals other than cats or dogs, including farm animals or animals at a petting zoo?"

1 = Yes

2 = No

DON'T KNOW

REFUSAL

-----  
PB\_Q3c

"In the last 48 hours have you Eaten any sushi or raw shell fish such as crab, oyster, or mussels?"

1 = Yes  
2 = No  
DON'T KNOW  
REFUSAL

---

PB\_Q3d

"In the last 48 hours have you eaten any rare, raw, or undercooked meat?"

1 = Yes  
2 = No  
DON'T KNOW  
REFUSAL

---

PB\_Q3e

"In the last 48 hours have you eaten any runny or raw eggs?"

1 = Yes  
2 = No  
DON'T KNOW  
REFUSAL

---

PB\_Q3f

"In the last 48 hours have you eaten a prepackaged sandwich?"

NOTE: Please do not include any home-made sandwiches or hot sandwiches.

1 = Yes  
2 = No  
DON'T KNOW  
REFUSAL

---

PB\_Q3g

"In the last 48 hours have you eaten any fresh fruit, vegetables, or salad greens?"

1 = Yes  
2 = No  
DON'T KNOW  
REFUSAL

---

PB\_Q3h

"In the last 48 hours have you eaten a hamburger?"

1 = Yes  
2 = No  
DON'T KNOW  
REFUSAL

---

PB\_Q16

"When was the last time you were involved in any water activity before today?"

1 = Past 3 days,  
2 = 4-7 days,  
3 = More than 7 days ago but less than 30 days (one month),  
4 = 30 days(one month) or more ago  
DON'T KNOW  
REFUSAL

---

PB\_Q17

"Approximately how many miles did you travel today to get here today?"

Enter a number between 0 and 500.  
Enter 0 for less than a mile.

---

PB\_Q18a

"(INTERVIEWER): Do not ask children this question.

Did you use any tobacco while at the <LOCATION> today?"

1 = Yes  
2 = No → SKIP TO Q19River  
DON'T KNOW → SKIP TO Q19River  
REFUSAL → SKIP TO Q19River

---

IF YES TO PB\_Q18a:

PB\_Q18b

"Was that cigarettes, cigars, a pipe, or chewing tobacco?"

1 = Cigarettes,  
2 = Cigars,  
3 = Pipe,  
4 = Chewing tobacco,  
5 = Other (SPECIFY)  
DON'T KNOW  
REFUSAL

-----  
IF YES TO PB\_Q18a:

PB\_Q18c

"How much did you use?"

(PROBE): How many cigarettes, cigars, pipes did you smoke or pinches of tobacco did you chew?

Enter a number from 1 to 100.

-----  
PB\_Q19River

"In the past 12 months, how many times have you used the Chicago River for any water recreational activities?"

Enter a number from 0 to 365.

(PROBE): Your best estimate is fine."

-----  
PB\_Q19Lake

"In the past 12 months, how many times have you used Lake Michigan for any water recreational activities?"

Enter a number from 0 to 365.

(PROBE): Your best estimate is fine."

-----  
PB\_Q19Lagoon

IF PBS2loc = SKOKIE LAGOON, DES PLAINES RIVER, KANKAKEE RIVER, FOX RIVER OR OTHER GENERAL AREA WATERWAY:

"In the past 12 months, how many times have you used the (SPECIFY GENERAL AREA WATERWAY LOCATION) for any water recreational activities?"

Enter a number from 0 to 365.

(PROBE): Your best estimate is fine."

-----  
PB\_Q19

"On a scale from 0 to 10 where 0 is not at all risky and 10 is very risky, can you tell me how

much of a health risk you think it is to do water sports on the Chicago River?

(PROBE): We are not asking about safety, only health."

-----  
PB\_Q8Addr

"May I please have your mailing address so that we can send you your \$35 'Thank You' check once you have completed the final telephone interview? You should receive your check in about 6-8 weeks.

Enter Street Address. Verify Spelling."

-----  
PB\_Q8City

Enter City. Verify Spelling."

-----  
PB\_Q8State

Enter State. Use Standard 2-Letter Abbreviation."

-----  
PB\_Q8Zip

Enter 5-Digit Zip Code."

-----  
PB\_Thanks

"Thank you for your assistance on this survey. We will call you 2, 5 and 21 days from today. If you have any questions or concerns you can reach us at the numbers provided in the consent document.

-----  
IF RESPONDENT DECLINED TO GIVE ADDRESS:

PB\_InelA

"I'm sorry. In order to be eligible to participate in the rest of the survey we would need your mailing address to mail your 'Thank you' check. Thank you for your time."

-----  
PB\_Phone

(INTERVIEWER): Was the interview completed in person or over the phone?

1 = In person  
2 = Over the phone

---

PB\_Proxy

Was this interview completed by a proxy respondent?

1 = Yes  
2 = No  
DON'T KNOW  
REFUSAL

---

# **QAPP 2**

## **Appendix 5**

### **Field Survey A**

**UNIVERSITY OF ILLINOIS, CHICAGO  
CHEERS FIELD SURVEY  
PART A**

**Interviewer Name (Part A):** .....  
Last First

**CAWs: Location**.....Drop down menu: Skokie Rowing Center, Clark Park, North Avenue, Alsip, Worth, Little Calumet River, 28 street, other  
 If other: Free text

**General Area Waterways: Location**.....Drop down menu: Leone Beach, Montrose Harbor, Wilson Beach, Belmont Harbor, Diversey Harbor, Jackson Park Harbor, Skokie Lagoons, Des Plaines River, Kankakee River, Fox River, other  
 If other: Free text

**ENTER 6-digit Case Identification Number:** \_\_\_\_\_

Date: \_\_\_\_ / \_\_\_\_ / \_\_\_\_

Start Time OF Field Survey A:      AM / PM

(computer to populate this field)

(computer to populate this field)

**Hi, my name is \_\_\_\_\_.** In order for us to find out more about people like you who participate in outdoor activities, I will ask you a few questions about yourself.

Q1. Please tell me your first name, last name and birth month/year. (INTERVIEWER: CODE GENDER.)

First Name	Last Name	Date of Birth mm/yyyy	Gender
		___/___ RF DK	M F RF DK

**Note: PROGRAM decides if this is proxy interview, based on child's age. If child is below 7 years of age interviewer is prompted to request parent to answer the questions.**

Q1a. Do you consider yourself to be ... SELECT ALL THAT APPLY.

- |                                      |  |
|--------------------------------------|--|
| 1. White,                            | 5. Native Hawaiian or Other Pacific Islander, or |
| 2. Black or African American,        | 6. Asian?  |
| 3. Hispanic,                         | 7. Other: Specify _____                          |
|                                      | 8. Refused                                       |
| 4. American Indian or Alaska Native, | 9. Don't Know                                    |

Q1b. Are you here **today** with any people who live with you, such as family members or roommates? Y N RF DK, or If No (Skip to Q2)

Q1c. How many people who you live with are here today? Enter Number. (Please do not include yourself)

Q1d. How many of those people are enrolled or enrolling in the CHEERS study today? Enter Number. (Please do not include yourself)



Q2. Some people swim, canoe, kayak, fish, SCUBA dive, or participate in water recreational activities at places such as beaches, water parks, public pools, private pools, or wading pools. During the past 7 days, have you participated in any water recreational activities anywhere?

- |            |            |
|------------|------------|
| YES        | 1 Go To Q3 |
| NO         | 2 Go To Q5 |
| REFUSED    | 7 Go To Q5 |
| DON'T KNOW | 8 Go To Q5 |

Q3. Where did you engage in these water recreational activity/ activities? Check all that apply. **PROBE: If BEACH, ask – was that an ocean, lake or river?**

Location		
Lake	Y N RF DK	<b>If YES , Were any of these activities at Lake Michigan</b>
River	Y N RF DK	<b>If YES , Were any of these activities at Chicago River or Calumet-Sag channel</b>
Lagoon	Y N RF DK	<b>If YES, Were any of these activities at Skokie Lagoon</b>
Water park	Y N RF DK	
Public Pool	Y N RF DK	
Private pool	Y N RF DK	
Wading pool	Y N RF DK	
Ocean	Y N RF DK	
Other	Specify:	

Q4. During any of these water recreational activities.....

a. Did any part of your body get wet at all? If NO, GoTo Q5	Y N RF DK
b. If YES, did your face/head get wet?	Y N RF DK
c. Did you get any water in your mouth? If NO, GoTo Q5	Y N RF DK
d. If YES, did you swallow any water?	Y N RF DK

Q5. As mentioned earlier we are interested in asking about your health in the next 3 weeks. **May I please have the best phone number where we can reach you at over the next 3 weeks?**

YES ..... 1      **GO TO Q6a**  
 NO ..... 2      **terminate survey**

**(IF NECESSARY): As mentioned earlier we will be calling 2,5, and 21 days from today to ask you a few questions about your health.**

**INTERVIEWER:** We will end the interview here since a contact telephone number is required to complete the telephone interview that I mentioned. Thank you for speaking with us.

Q6a. Which **is the best** phone number(s) to reach you at during this time? **INTERVIEWER: COLLECT AS MANY PHONE NUMBERS AND EXTENTIONS AS POSSIBLE.**

Morning	8:00 AM-12:00 noon	Home phone
Afternoon	12:01 PM-5:00 PM	Vacation phone
Evening	5:01 PM- 9:00 PM	cell phone
		other
Morning	8:00 AM-12:00 noon	Home phone
Afternoon	12:01 PM-5:00 PM	Vacation phone
Evening	5:01 PM- 9:00 PM	cell phone
		other
Morning	8:00 AM-12:00 noon	Home phone
Afternoon	12:01 PM-5:00 PM	Vacation phone
Evening	5:01 PM- 9:00 PM	cell phone
		other

**INTERVIEWER: Thank you.** We'll try to reach you during that (those) time(s).

**End A: IF non-water recreator proceed directly to Survey B.**

**IF water recreator ask: Will you be returning by (mention time) to complete Survey B?**

**IF "YES"- remind them to return to the CHEERS tent by (mention time) to complete Survey B and collect their gift card and t-shirt.**

**Interviewer make sure the data manager has the list of participants who will return to complete survey B.**

End Time for Field Survey A \_\_\_\_\_ AM /PM  
 (computer to populate this field)



# **QAPP 2**

## **Appendix 7**

### **Telephone Follow-up Interview**

UNIVERSITY OF ILLINOIS, CHICAGO  
CHEERS  
FOLLOW-UP TELEPHONE SURVEY

ENTER 6-digit Case Identification Number: \_\_\_\_\_

A1. Hello, my name is \_\_\_\_\_. May I speak to (RESPONDENT NAME: \_\_\_\_\_)?

- 1. AVAILABLE – GO TO A4
- 2. NOT AVAILABLE – GO TO A2
- 3. NEVER HEARD OF PERSON – GO TO A3
- 4. REFUSED – Too busy .....  
                   No longer interested .....  
                   Will not be available .....  
                   Other reason? .....  
                   Please specify: .....

A2. Recently, we spoke to (RESPONDENT) at [fill River/Lake location], and we're calling to complete the interview. If s/he isn't available- Could you please tell us what is the best time to reach him/her?

DATE:  
TIME:

A3. Is this number (\_\_\_\_) \_\_\_\_ \_\_\_\_ ? (VERIFY THE NUMBER ON THE CALL RECORD SHEET)

- 1. YES – COMPLETE NIRF
- 2. NO -- REDIAL THE NUMBER

A4. I'm calling about a follow-up health survey for the CHEERS study. Recently, we spoke to you at [fill River/Lake location]{IF NEEDED: Specify the location and date}; and we're calling back to complete the interview.

- 1. YES- CONTINUE Goto Section B
- 2. NO- SCHEDULE APPOINTMENT
- 3. NO- REFUSED - Too busy  
                   No longer interested .....  
                   Will not be available .....  
                   Other reason? .....  
                   Please specify: .....

IF ASKED TO CALL BACK OR SCHEDULE APPOINTMENT, SAY: The interview needs to be completed by [LAST DATE]. When would be the best time to call you before then?

DATE:  
TIME:

Symptom Intro

**B. Now I am going to ask you a few questions about how you have been feeling since we last spoke. Since we last spoke on (fill Date of survey or last telephone interview) [fill number of days] days ago.**

Note: Go through each symptom. If YES to any symptom, then Go to symptom detail questions. If NO to any symptom, Go to next symptom on the list. If NO to all symptoms, then skip to Section D.

Symptom	Y N RF DK	Symptom Detail
B1. Abdominal cramps or stomach ache	Y N RF DK	If Yes, Complete B1a- B1d.
B2. Diarrhea or loose bowels	Y N RF DK	If Yes, Complete B2a- B2d
B3. Nausea	Y N RF DK	If Yes, Complete B3a- B3d
B4. Vomiting	Y N RF DK	If Yes, Complete B4a- B4d
B5. Fever	Y N RF DK	If Yes, Complete B5a- B5e
B6. Headache	Y N RF DK	If Yes, Complete B6a- B6c
B7. Sore throat	Y N RF DK	If Yes, Complete B7a-B7d
B8. Cough	Y N RF DK	If Yes, Complete B8a-Be
B9. A Cold or a runny or stuffy nose	Y N RF DK	If Yes, Complete B9a-B9d
B10. Earache or ear infection	Y N RF DK	If Yes, Complete B10a-B10d
B11. Eye irritation	Y N RF DK	If Yes, Complete B11a-B11d
B12. Drainage or crusting in eyes	Y N RF DK	If Yes, Complete B12a-B12d
B13. Any areas on your skin that are sore or draining	Y N RF DK	If Yes, Complete B13a-B13h
B14. Rash or Itchy skin	Y N RF DK	If Yes, Complete B14a-B14f

B. Symptom Detail

INTERVIEWER WILL REFER TO HARD-COPY CALENDAR TO NEGOTIATE DATES.

B1a. On what date did the abdominal cramping or stomach ache start?

DATE: \_\_\_\_\_ / \_\_\_\_\_ / 200  
 REFUSED 97  
 DON'T KNOW 98

B1b. Do you still have the abdominal cramping or stomach ache?

YES  
 NO Go to B1c.  
 REFUSED Go to B1c.  
 DON'T KNOW Go to B1c.

B1c. On what date did the abdominal cramps or stomach ache end?

DATE: \_\_\_\_\_ / \_\_\_\_\_ / 200  
 REFUSED 97  
 DON'T KNOW 98

B1d. Was this menstrual cramps? Ask only for female participants 12 years or older.

YES	1
NO	2
REFUSED	97
DON'T KNOW	98

B2a. On what date did the diarrhea or loose bowels start?

DATE: _____ / _____ / <u>200</u>	
REFUSED	97
DON'T KNOW	98

**B2b. Do you still have diarrhea or loose bowels?**

YES  
 NO Go to B2c.  
 REFUSED Go to B2c.  
 DON'T KNOW Go to B2c.

**B2c. On what date did the diarrhea or loose bowels end?**

<b>DATE: _____ / _____ / <u>200</u></b>	
<b>REFUSED</b>	<b>97</b>
<b>DON'T KNOW</b>	<b>98</b>

B2d. What is the maximum number of times you had diarrhea in a 24-hour period?

[NUMBER PER DAY:] |\_\_|\_\_|\_\_|

REFUSED	97
DON'T KNOW	98

B3a. On what date did the nausea start?

DATE: _____ / _____ / <u>2007</u>	
REFUSED	97
DON'T KNOW	98

**B3b. Do you still have nausea?**

YES  
 NO Go to B3c.  
 REFUSED Go to B3c.  
 DON'T KNOW Go to B3c.

**B3c. On what date did the nausea end?**

<b>DATE: _____ / _____ / <u>200</u></b>	
<b>REFUSED</b>	<b>97</b>
<b>DON'T KNOW</b>	<b>98</b>

B3d. Are you pregnant? Ask only adult females.

YES	1
NO	2
REFUSED	97
DON'T KNOW	98

B4a. On what date did you start vomiting?

DATE: _____ / _____ / <u>2007</u>	
REFUSED	97
DON'T KNOW	98

**B4b. Do you still have the vomiting?**

YES  
NO Go to B4c.  
REFUSED Go to B4c.  
DON'T KNOW Go to B4c.

**B4c. On what date did the vomiting end?**

<b>DATE: _____ / _____ / <u>200</u></b>	
<b>REFUSED</b>	<b>97</b>
<b>DON'T KNOW</b>	<b>98</b>

B4d. Are you pregnant? Ask only adult females.

YES	1
NO	2
REFUSED	97
DON'T KNOW	98

B5a. On what date did the fever start?

DATE: _____ / _____ / <u>2007</u>	
REFUSED	97
DON'T KNOW	98

**B5b. Do you still have fever?**

**YES**  
**NO Go to B5c.**  
**REFUSED Go to B5c.**  
**DON'T KNOW Go to B5c.**

**B5c. On what date did the fever end?**

<b>DATE: _____ / _____ / <u>200</u></b>	
<b>REFUSED</b>	<b>97</b>
<b>DON'T KNOW</b>	<b>98</b>



B5d. Was your temperature taken using a thermometer?

YES	1
NO	2 Go To B6a
REFUSED	97 Go To B6a
DON'T KNOW	98 Go To B6a

B5e. What is the highest temperature that you had?

[TEMPERATURE:] \_\_\_\_\_

Range: 98.6 to 106.9

REFUSED	97
DON'T KNOW	98

B6a. On what date did the headache start?

DATE: _____ / _____ / <u>2007</u>	
REFUSED	97
DON'T KNOW	98

**B6b. Do you still have a headache?**

**YES**  
**NO Go to B6.**  
**REFUSED Go to B6c.**  
**DON'T KNOW Go to B6c.**

**B6c. On what date did the headache end?**

<b>DATE: _____ / _____ / <u>200</u></b>	
<b>REFUSED</b>	<b>97</b>
<b>DON'T KNOW</b>	<b>98</b>

B7a. On what date did the sore throat start?

DATE: _____ / _____ / <u>2007</u>	
REFUSED	97
DON'T KNOW	98

**B7b. Do you still have a sore throat?**

**YES**  
**NO Go to B7c.**  
**REFUSED Go to B7c.**  
**DON'T KNOW Go to B7c.**

**B7c. On what date did the sore throat end?**

DATE: _____ / _____ / <u>200</u>	
REFUSED	97
DON'T KNOW	98

B7d. Do you think this sore throat was related to allergies?

YES	1
NO	2
REFUSED	97
DON'T KNOW	98

B8a. On what date did the cough start?

DATE: _____ / _____ / <u>2007</u>	
REFUSED	97
DON'T KNOW	98

**B8b. Do you still have a cough?**

**YES**  
**NO Go to B8c.**  
**REFUSED Go to B8c.**  
**DON'T KNOW Go to B8c.**

B8c. Did you cough up phlegm?

YES	1
NO	2
REFUSED	97
DON'T KNOW	98

**B8d. On what date did the cough end?**

DATE: _____ / _____ / <u>200</u>	
REFUSED	97
DON'T KNOW	98

B8e. Do you think this cough was related to allergies?

YES	1
NO	2
REFUSED	97
DON'T KNOW	98

B9a. On what date did your cold or runny or stuffy nose start?

DATE: _____ / _____ / <u>2007</u>	
REFUSED	97
DON'T KNOW	98

**B9b. Do you still have a cold or runny or stuffy nose?**

**YES**  
**NO Go to B9c.**  
**REFUSED Go to B9c.**  
**DON'T KNOW Go to B9c.**

**B9c. On what date did the cold or runny or stuffy nose end?**

**DATE: \_\_\_\_\_ / \_\_\_\_\_ / 200**  
**REFUSED 97**  
**DON'T KNOW 98**

**B9d. Do you think was this cold or runny or stuffy nose was related to allergies?**

**YES 1**  
**NO 2**  
**REFUSED 97**  
**DON'T KNOW 98**

**B10a. On what date did the earache/ear infection start?**

**DATE: \_\_\_\_\_ / \_\_\_\_\_ / 2007**  
**REFUSED 97**  
**DON'T KNOW 98**

**B10b. Do you still have an earache?**

**YES**  
**NO Go to B10c**  
**REFUSED Go to B10c**  
**DON'T KNOW Go to B10c**

**B10c. On what date did the earache end?**

**DATE: \_\_\_\_\_ / \_\_\_\_\_ / 200**  
**REFUSED 97**  
**DON'T KNOW 98**

**B10d. Was this earache or ear infection in your.....**

**Left ear,**  
**Right ear**  
**Both ears**  
**REFUSED 97**  
**DON'T KNOW 98**

**B11a. On what date did the eye irritation start?**

**DATE: \_\_\_\_\_ / \_\_\_\_\_ / 2007**  
**REFUSED 97**  
**DON'T KNOW 98**

**B11b. Do still have eye irritation?**

**YES**  
**NO Go to B11c**  
**REFUSED Go to B11c**  
**DON'T KNOW Go to B11c**

**B11c. On what date did the eye irritation end?**

**DATE: \_\_\_\_\_ / \_\_\_\_\_ / 200**  
**REFUSED 97**  
**DON'T KNOW 98**

**B11d. Was the irritation in your...**

Left eye,  
Right eye  
Both eyes  
**REFUSED 97**  
**DON'T KNOW 98**

**B12a. On what day did the eye drainage or crusting start?**

**DATE: \_\_\_\_\_ / \_\_\_\_\_ / 2007**  
**REFUSED 97**  
**DON'T KNOW 98**

**B12b. Do you still have eye drainage or crusting?**

**YES**  
**NO Go to B12c**  
**REFUSED Go to B12c**  
**DON'T KNOW Go to B12c**

**B12c. On what date did the eye drainage or crusting end?**

**DATE: \_\_\_\_\_ / \_\_\_\_\_ / 200**  
**REFUSED 97**  
**DON'T KNOW 98**

**B12d. Was this drainage or crusting in your.....**

Left eye,  
Right eye,  
Both eyes  
**REFUSED 97**  
**DON'T KNOW 98**

B13a. Where is the soreness or drainage located?

<b>Right side</b>		<b>Left side</b>	
Head/ Face	Y N RF DK	Head/ Face	Y N RF DK
Neck	Y N RF DK	Neck	Y N RF DK
Upper Arm	Y N RF DK	Upper Arm	Y N RF DK
Fore Arm	Y N RF DK	Fore Arm	Y N RF DK
Elbow	Y N RF DK	Elbow	Y N RF DK
Hand	Y N RF DK	Hand	Y N RF DK
Fingers	Y N RF DK	Fingers	Y N RF DK
Thigh	Y N RF DK	Thigh	Y N RF DK
Lower leg	Y N RF DK	Lower leg	Y N RF DK
Ankle/ Foot	Y N RF DK	Ankle/ Foot	Y N RF DK
Abdomen	Y N RF DK	Abdomen	Y N RF DK
Chest	Y N RF DK	Chest	Y N RF DK
Back	Y N RF DK	Back	Y N RF DK
Knee	Y N RF DK	Knee	Y N RF DK
Toes	Y N RF DK	Toes	Y N RF DK
Other: Specify	Y N RF DK	Other: Specify	Y N RF DK

B13d. On what day did you first notice soreness or drainage?

DATE: \_\_\_\_\_ / \_\_\_\_\_ / 2007

REFUSED

97

DON'T KNOW

98

B13e. Do you still have the soreness or drainage?

**YES**

**NO Go to B13f**

**REFUSED Go to B13f**

**DON'T KNOW Go to B13f**

B13f. On what date did the soreness or drainage end?

DATE: \_\_\_\_\_ / \_\_\_\_\_ / 200

REFUSED

97

DON'T KNOW

98

B13g. Do you think this soreness or drainage was related to insect bites?

Y

N

RF

DK

B13h. Do you think this soreness or drainage was related to allergies?

Y

N

RF

DK

B14a. On what day did the rash or itchy skin start?

DATE: \_\_\_\_\_ / \_\_\_\_\_ / 2007

REFUSED

97

DON'T KNOW

98

**B14b. Do you still have the rash or itchy skin?**

- YES
- NO Go to B14c
- REFUSED Go to B14c
- DON'T KNOW Go to B14c

**B14c. On what date did the rash or itchy skin end?**

DATE: \_\_\_\_\_ / \_\_\_\_\_ / 200  
 REFUSED

97

**B14d. Where is the rash located?**

Right side		Left side	
Head/ Face	Y N RF DK	Head/ Face	Y N RF DK
Neck	Y N RF DK	Neck	Y N RF DK
Upper Arm	Y N RF DK	Upper Arm	Y N RF DK
Fore Arm	Y N RF DK	Fore Arm	Y N RF DK
Elbow	Y N RF DK	Elbow	Y N RF DK
Hand	Y N RF DK	Hand	Y N RF DK
Fingers	Y N RF DK	Fingers	Y N RF DK
Thigh	Y N RF DK	Thigh	Y N RF DK
Lower leg	Y N RF DK	Lower leg	Y N RF DK
Ankle/ Foot	Y N RF DK	Ankle/ Foot	Y N RF DK
Abdomen	Y N RF DK	Abdomen	Y N RF DK
Chest	Y N RF DK	Chest	Y N RF DK
Back	Y N RF DK	Back	Y N RF DK
Knee	Y N RF DK	Knee	Y N RF DK
Toes	Y N RF DK	Toes	Y N RF DK
Other: Specify	Y N RF DK	Other: Specify	Y N RF DK

**B14e. Do you think this rash or itchy skin was related to insect bites?**

- Y
- N
- RF
- DK

**B14f. Do you think this rash or itchy skin was related to allergies?**

- Y
- N
- RF
- DK

**NOTE: IF ANY OF THE SYMPTOMS (B1-B14) WERE REPORTED IN THE FIELD SURVEY B OR PREVIOUS PHONE SURVEY, THEN ASK QB15 –**

**B15. Have you had a 48 hour symptom free period since you reported the (symptom) during the field survey B or previous telephone interview on (enter date)?**

- Y
- N

**RF**  
**DK**

C. You said you had [LIST OF SYMPTOMS FROM B1-B14]. We would now like to discuss how this illness or these symptoms affected your daily activities.

**C1. Did these symptoms prevent you from performing daily activities such as school, work or recreation?**

<b>YES</b>	<b>1</b>
<b>NO</b>	<b>2</b>
<b>REFUSED</b>	<b>97</b>
<b>DON'T KNOW</b>	<b>98</b>

**C2 For how long were you prevented from performing daily activities?**

\_\_\_\_ days (IF IN HOURS, i.e. <1 DAY, THEN CODE AS ZERO)

<b>REFUSED</b>	<b>97</b>
<b>DON'T KNOW</b>	<b>98</b>

**C3. Did you consult a healthcare provider over the phone or in person about any of these symptoms?**

<b>YES</b>	<b>1</b>
<b>NO</b>	<b>2</b>
<b>REFUSED</b>	<b>97</b>
<b>DON'T KNOW</b>	<b>98</b>

**If YES to C3 then ask C4-C8**

**C4 What illness did the health care provider say (you) had, if any?**

\_\_\_\_\_

<b>NONE</b>	
<b>REFUSED</b>	<b>97</b>
<b>DON'T KNOW</b>	<b>98</b>

**C5 Did you visit an emergency room for this illness?**

<b>YES</b>	<b>1</b>
<b>NO</b>	<b>2</b>
<b>REFUSED</b>	<b>97</b>
<b>DON'T KNOW</b>	<b>98</b>

**C6 Were you admitted in the hospital for this illness?**

<b>YES</b>	<b>1</b>
<b>NO</b>	<b>2</b>
<b>REFUSED</b>	<b>97</b>
<b>DON'T KNOW</b>	<b>98</b>

**C7 Did you receive a prescription for an antibiotic or other drug to treat this illness?**

YES	1
NO	2
REFUSED	97
DON'T KNOW	98

**C8 Did you use any over-the-counter medications, including things like special drinks, for these symptoms?**

YES	1
NO	2
REFUSED	97
DON'T KNOW	98

**D. Now I am going to ask you a few questions about your recent water recreational activities .**

**D1. Since we last spoke on (Fill date of last interview) x days ago, have you participated in any water recreational activities anywhere?**

YES	1 D2
NO	2 Go to E1
REFUSED	7 Go to E1
DON'T KNOW	8 Go to E1

**D2. Since we last spoke on (Fill date of last interview) x days ago, on how many days have you participated in these water recreational activities ?**

Enter number: \_\_\_\_\_

**D3. Record date of water recreational activities since last interview. Enter dates: \_\_\_\_\_---**

**D4. Where did you engage in these water recreational activity/activities? Check all that apply. If Beach, ask – Was it ocean, lake or river?**

Location		
Lake	Y N RF DK	If YES , ask if Lake Michigan
River	Y N RF DK	If YES , ask if Chicago River or Calumet-Sag channel
Lagoon	Y N RF DK	If YES, ask if Skokie Lagoon
Beach	Y N RF DK	
Water park	Y N RF DK	
Public Pool	Y N RF DK	
Private pool	Y N RF DK	
Wading pool	Y N RF DK	
Ocean	Y N RF DK	
Other	Specify: _____	



**D5.** During any of these water recreational activities.....

a. Did any part of your body get wet at all?	Y N RF DK
b. If YES, Did your face or head get wet?	Y N RF DK
c. Did you get any water in your mouth? If NO, Go to D6	Y N RF DK
d. If YES, did you swallow any water?	Y N RF DK Y N RF DK

**E.** I'd like to ask you about some other exposures you may have had since we last spoke [fill date of survey or last telephone interview].

**E1.** Since we last spoke on [fill date of survey or last telephone interview].....

a. Have you touched any cat or dog?	Y N RF DK
b. Have you touched any other animals, other than cats or dogs, including farm animals or animals at a petting zoo?	Y N RF DK
d. Have you eaten any sushi or raw shell fish (such as crab, oyster, or mussels)?	Y N RF DK
d. Have you eaten any rare/raw/undercooked meat?	Y N RF DK
e. Have you eaten any runny or raw eggs?	Y N RF DK
f. Have you eaten a pre-packaged sandwich?	Y N RF DK
h. Have you eaten any fresh fruit, vegetables, or salad greens?	Y N RF DK
i. Have you eaten a hamburger?	Y N RF DK

**E2.** Since we last spoke [fill date of survey or last telephone interview], have you come into contact with someone who had .....

a. Vomiting or diarrhea?	Y N RF DK	IF YES Goto E3
b. A cold or sore throat or cough?	Y N RF DK	IF YES Goto E3
c. An eye infection?	Y N RF DK	IF YES Goto E3

**E3.** Were any of those contacts with people who live with you, such as family members or roommates?

Yes GOTO E3a

No GOTO F

**E3a.** How many of those people were enrolled in this CHEERS study?

ENTER NUMBER: \_\_\_\_\_

**E3b.** And what are their names?

First and Last Name	Gender
I RF DK	M F RF DK
RF DK	M F RF DK
RF DK	M F RF DK
RF DK	M F RF DK

F. INTERVIEWER: Reconfirm phone numbers and call back times.

**F1. Which is the best phone number(s) to reach you at during this time? INTERVIEWER: COLLECT AS MANY PHONE NUMBERS AND EXTENTIONS AS POSSIBLE.**

Morning noon	8:00 AM-12:00	Home phone Vacation phone cell phone other
Afternoon	12:01 PM-5:00 PM	
Evening	5:01 PM- 9:00 PM	
Morning noon	8:00 AM-12:00	Home phone Vacation phone cell phone other
Afternoon	12:01 PM-5:00 PM	
Evening	5:01 PM- 9:00 PM	
Morning noon	8:00 AM-12:00	Home phone Vacation phone cell phone other
Afternoon	12:01 PM-5:00 PM	
Evening	5:01 PM- 9:00 PM	

EXIT STATEMENT

Note: If this is the Day 2 or Day 5 interview then ask for a date and time to schedule next telephone interview. Make sure to inform the participant that interview must be completed within a certain period. **Note: Schedule appointment for home visit by the nurse if any symptoms need clinical evaluation.**

**INTERVIEWER: Thank you for your assistance on this survey. We will call you again in about (x) days to complete the next telephone interview. After completing the final telephone interview, you will receive a \$35 check within 30 days.**

At the end of day 21 telephone interview. This completes our telephone interview and your participation. I'd like to verify your address so we can mail a check for \$35 to you. (VERIFY ADDRESS ON CALL SHEET.) You will receive your check in 30 days. Thank you for your participation in this study. Goodbye.

**F2. INTERVIEWER: Was this interview with a proxy respondent?**

YES

NO

**F3. INTERVIEWER: Is there anything you want to add about respondent comprehension, any issues with the answers to specific items, or anything else that affects data quality?**

YES Specify: \_\_\_\_\_

NO

INTERVIEWER NAME: FIRST \_\_\_\_\_ LAST \_\_\_\_\_

**PROGRAM: Home visit triggers.**

If YES to 1 or more of the following symptoms –

<b>B1. Abdominal cramps or stomach ache</b>	<b>Stool sample (ONLY IF THIS IS NOT MENSTRUAL CRAMPS) GOTO G1</b>
<b>B2. Diarrhea or loose bowels</b>	<b>Stool sample Goto G1</b>
<b>B4. Vomiting</b>	<b>Stool sample Goto G1</b>
<b>B3. Nausea</b>	<b>Stool sample. Only if present along with symptoms B1, B2 or B4. OR with FEVER. Goto G1</b>
<b>B12. Drainage from eyes or crusting in eyes. Please ask if there is any discharge from the eyes? If YES, only then get a sample. If it is only a sore area we do not want a sample.</b>	<b>Eye discharge sample. Goto G2 Obtain sample only if there is any eye discharge.</b>
<b>B13. Any areas on your skin that are sore or sore or draining</b>	<b>Skin discharge sample. Goto G2</b>

**Decision tree for home visits and stool collection: This is followed when the survey triggers the home visit or stool sample collection.**

**G1. INTERVIEWER: We will need a stool sample from you.**

1. Have you already collected a stool sample? Y N (Goto G9 )
2. If YES, When did you collect it? (How many hours back?)
3. Have you called the courier service to schedule a pick-up? Y N (Goto G5)
4. If YES- Thank participant. Continue to finish survey.
5. If participant has collected the stool sample in the past 6 hours, but not called the courier service then- Will you be at home in the next 2 hours? Y N (Goto G8 )
6. If YES, may I send the courier service home to pick-up the sample? Y N (Goto G8)
7. If YES, confirm address and contact courier service to pick-up sample in the next 2 hours. Thank participant and continue to finish the survey.
8. If NO, Ok- will you call the courier service to set up a convenient time to pick-up the sample. (The interviewer will have all details of the courier service and how samples need to be collected and stored- if needed by the participant)
9. Do you have a stool kit available? Y N (Goto G13)
10. If YES, Do you understand how to use the kit? Y N (Goto G12)
11. If YES, please follow the instructions on the stool kit and collect the sample. Kindly contact the courier service using the number on the kit for a pick-up. (The interviewer will have all details of the courier service and how samples need to be collected and stored- if needed by the participant)
12. If NO, The interviewer will have all details of the courier service and how samples need to be collected and stored- if needed by the participant.

**13. OK- We will send you a stool kit. After that please follow the instructions on the stool kit and collect the sample. Kindly contact the courier service using the number on the kit for a pick-up.**

**END: Is there any other question or concern regarding the stool collection that I can answer? If YES, Specify:\_\_\_\_\_**

**G2. INTERVIEWER: A CHEERS study clinician will call you to schedule a home visit. The clinician may examine your eyes and take an eye swab, or swab your skin (depending on the symptom). Interviewer has to confirm the address and pass on details to the CHEERS nurse.**

**If a participant calls in with symptoms in between their day 2, 5 and 21 survey then we follow the same decision tree. However, in addition we collect other case details too:**

- 1. Case ID**
- 2. Participant First and Last Name**
- 3. Symptom experienced**
- 4. Start date**
- 5. Does symptom still persist? If NO- then end date.**
- 6. Go through G1 or G2 based on home visit or stool collection trigger.**

## **QAPP 2**

### **Appendix 8: CHEERS Pilot Study Protocol & IRB Approval Letter**

# **QAPP 2**

## **Appendix 8A**

### **CHEERS Pilot Study Protocol and IRB Approval Letter**

#### **Pilot Consent Document**

Leave box empty - For office use only

Flesch-Kincaid Grade level 8.9

University of Illinois at Chicago  
**CONSENT FOR PARTICIPATION IN RESEARCH**

“PILOT STUDY FOR EVALUATING THE CHICAGO WATER RECREATION STUDY  
FIELD AND TELEPHONE QUESTIONNAIRES”  
(To be administered in English)

**Why am I being asked?**

The University of Illinois at Chicago (UIC) School of Public Health is planning a research study on the health of people in the Chicago area who take part in outdoor recreation. You are being asked to be in this pilot study because you are active in outdoor recreation in or around Lake Michigan and the Chicago River. We ask that you read this form and ask any questions you may have before agreeing to be in the research.

Your taking part in this research is voluntary. Your decision whether or not to be in the study will not affect your current or future relationship with the University of Illinois at Chicago (UIC). If you decide to be part of the research, you may withdraw at any time without affecting that relationship.

**Why is this research being done?**

We want to know if the questionnaires developed for a research study are user friendly. Results could be used for improving the quality of the questionnaires to be used in a larger study.

**What is the purpose of this research?**

The main purpose of this pilot study is to evaluate and refine the field and telephone questionnaires developed for a larger study on outdoor recreators in the Chicago area.

**What procedures are involved?**

If you agree to be in this pilot study, we would ask you to do the following things:

- We will first ask you to read and sign this consent form.



- Then we will ask you a few questions, about your current health and your recreational activity today. This will take about 8-12 minutes.
- We then will ask for your feedback about the questionnaire. This will take about 10 to 15 minutes.
- We will ask you for your address and phone number, as we will try to contact you.
- We will call you 1 or 2 days from today to ask you about how you feel. This will take about 10 minutes.
- We then will ask your feedback on the telephone questionnaire that will take about 10-15 minutes.

### **What are the potential risks and discomforts?**

The research has no major physical risks or discomforts other than the time involved. You may feel uncomfortable while answering certain questions during the survey/interview. You have the right to refuse to answer any questions at any time. We will do the telephone follow-up at a time that you tell us is convenient for you.

You may be concerned about how we will store/protect your data. We will protect your confidentiality and to keep your answers private. **When the results of the research are published or discussed in conferences, no information will be included that would reveal your identity.**

### **Are there benefits to taking part in the research?**

There are no direct benefits to the participant from being in this pilot study.

The results from this pilot study may help future research subjects better understand the survey questions being asked.

### **Will I be told about new information that may affect my decision to participate?**

During the course of the pilot study, you will be informed of any significant new findings (either good or bad), such as changes in the risks or benefits resulting from participation in the research or new alternatives to participation that might cause you to change your mind about continuing in the study. If new information is provided to you, your consent to continue participating in this study will be re-obtained.

### **What about privacy and confidentiality?**

The only people who will know that you are a research subject are members of the research team. No information about you, or provided by you during the research will be disclosed to others without your written permission, except:

- If necessary to protect your rights or welfare (for example, if you are injured and need emergency care or when the UIC Institutional Review Board monitors the research or consent process); or

- If required by law.

We respect your privacy. All computer files with identifiers will be password-protected. Any hard copies of the forms/files will be stored in locked cabinets and will be destroyed as soon as data collection is complete. When the results of the research are published or discussed in conferences, no information will be included that would reveal your identity.

**What if I am injured as a result of my participation?**

No injury is expected to occur as a result of your participation in this research. In the event injury related to this research, treatment would be available through the UIC Medical Center. However, you or your third party payer, if any, will be responsible for payment of this treatment. If you feel you have been injured, you may contact Jacqueline Wuellner at 312-996-3395.

**What are the costs for participating in this research?**

There are no costs to you for participating in this research.

**Will I be reimbursed for any of my expenses or paid for my participation in this research?**

You will receive a total of up to \$ 25 in gift certificates for participating in this research according to the following schedule:

If you decide to participate, we will give you a \$15 gift card after you have answered the questions today.

After completing the survey and final telephone interview: a \$10 check will be sent to you in the mail.

**Can I withdraw or be removed from the study?**

Your participation in this research is VOLUNTARY. If you choose not to participate, that will not affect your relationship with UIC or your right to health care or other services to which you are otherwise entitled. If you decide to participate, you are free to withdraw your consent and discontinue participation at any time without affecting your future care at UIC.

**Who should I contact if I have questions?**

The research contact for this study is Dr. Sam Dorevitch. You may ask any questions you have now. If you have questions later, you may contact the Dr.Dorevitch at: 312-355-3629 or 312-413-1739.

**What are my rights as a research subject?**

If you feel you have not been treated according to the descriptions in this form, or you have any questions about your rights as a research subject, you may call the Office for the Protection of

Research Subjects (OPRS) at 312-996-1711 (local) or 1-866-789-6215 (toll-free) or e-mail OPRS at [uicirb@uic.edu](mailto:uicirb@uic.edu).

**Remember:**

Your participation in this research is voluntary. Your decision whether or not to participate will not affect your current or future relations with the University. If you decide to participate, you are free to withdraw at any time without affecting that relationship. You will be given a copy of this form for your information and to keep for your records.

**Signature of Subject or Legally Authorized Representative**

I have read (or someone has read to me) the above information. I have been given an opportunity to ask questions and my questions have been answered to my satisfaction. I agree to participate in this research. I have been given a copy of this form.

\_\_\_\_\_  
Signature

\_\_\_\_\_  
Date

\_\_\_\_\_  
Printed Name

\_\_\_\_\_  
Signature of Researcher

\_\_\_\_\_  
Date (must be same as subject's)

\_\_\_\_\_  
Printed name of Researcher

\_\_\_\_\_  
Signature of Witness (if appropriate)

\_\_\_\_\_  
Date (must be same as subject's)

\_\_\_\_\_  
Printed name of Witness (if appropriate)

## **QAPP 2**

### **Appendix 8B**

#### **CHEERS Pilot Study Protocol and IRB Approval Letter**

#### **Field Pilot Survey Evaluation Form**

PILOT FIELD SURVEY EVALUATION FORM

Interviewer Name \_\_\_\_\_

Participant Name \_\_\_\_\_

Date of interview \_\_\_\_\_

Time of interview \_\_\_\_\_

1. Were there any questions that may be confusing for other people who will take this survey?

Y N RF DK

Notes: \_\_\_\_\_  
\_\_\_\_\_  
\_\_\_\_\_  
\_\_\_\_\_  
\_\_\_\_\_  
\_\_\_\_\_

2. How difficult was it to answer all of the questions?

Notes: \_\_\_\_\_  
\_\_\_\_\_  
\_\_\_\_\_  
\_\_\_\_\_  
\_\_\_\_\_  
\_\_\_\_\_

3. Is there anything that you think would be helpful to add to or take out of the questionnaire?

Y N RF DK

Notes: \_\_\_\_\_  
\_\_\_\_\_  
\_\_\_\_\_  
\_\_\_\_\_  
\_\_\_\_\_  
\_\_\_\_\_

4. Which questions were confusing or difficult to answer?

Notes: \_\_\_\_\_  
\_\_\_\_\_  
\_\_\_\_\_  
\_\_\_\_\_  
\_\_\_\_\_  
\_\_\_\_\_  
\_\_\_\_\_

5. What do you think about the length of the questionnaire?

Notes:

\_\_\_\_\_  
\_\_\_\_\_  
\_\_\_\_\_  
\_\_\_\_\_  
\_\_\_\_\_

6. Did any of the questions make you feel uncomfortable? If so, which ones?

Y N RF DK

Notes: \_\_\_\_\_  
\_\_\_\_\_  
\_\_\_\_\_  
\_\_\_\_\_  
\_\_\_\_\_  
\_\_\_\_\_

7. How would you feel if a nurse or doctor would examine your eyes, skin and ears after you took the survey?

Notes: \_\_\_\_\_  
\_\_\_\_\_  
\_\_\_\_\_  
\_\_\_\_\_  
\_\_\_\_\_  
\_\_\_\_\_

8. What do you think would be good ways to recruit people who (mention activity of participant) for this study?

Notes: \_\_\_\_\_  
\_\_\_\_\_  
\_\_\_\_\_  
\_\_\_\_\_  
\_\_\_\_\_  
\_\_\_\_\_  
\_\_\_\_\_  
\_\_\_\_\_  
\_\_\_\_\_  
\_\_\_\_\_  
\_\_\_\_\_  
\_\_\_\_\_  
\_\_\_\_\_  
\_\_\_\_\_

9. We want to know how wet people get when they (mention the participant's water-recreational activity). What would be good questions to ask people in order to find that out?

Notes: \_\_\_\_\_  
\_\_\_\_\_  
\_\_\_\_\_  
\_\_\_\_\_  
\_\_\_\_\_  
\_\_\_\_\_  
\_\_\_\_\_  
\_\_\_\_\_  
\_\_\_\_\_  
\_\_\_\_\_

10. Do you have any other suggestions for us when we do a research study about water contact, outdoor recreation, and health?

Notes: \_\_\_\_\_  
\_\_\_\_\_  
\_\_\_\_\_  
\_\_\_\_\_  
\_\_\_\_\_  
\_\_\_\_\_  
\_\_\_\_\_  
\_\_\_\_\_  
\_\_\_\_\_  
\_\_\_\_\_  
\_\_\_\_\_  
\_\_\_\_\_  
\_\_\_\_\_

## **QAPP 2**

### **Appendix 8C**

**CHEERS Pilot Study Protocol and IRB Approval Letter**

**Pilot Study Telephone Evaluation Form**



PILOT TELEPHONE QUESTIONNAIRE EVALUATION FORM

Interviewer Name \_\_\_\_\_

Participant Name \_\_\_\_\_

Date of call \_\_\_\_\_

Time of call \_\_\_\_\_

1. Were there any questions that you think may be confusing for other people who will take this survey?

Y N RF DK

Notes: \_\_\_\_\_  
\_\_\_\_\_  
\_\_\_\_\_  
\_\_\_\_\_  
\_\_\_\_\_  
\_\_\_\_\_  
\_\_\_\_\_

2. How difficult was it to answer the questions?

Y N RF DK

Notes: \_\_\_\_\_  
\_\_\_\_\_  
\_\_\_\_\_  
\_\_\_\_\_  
\_\_\_\_\_  
\_\_\_\_\_  
\_\_\_\_\_

3. Is there anything that you think would be helpful to add or take out of the questionnaire?

Y N RF DK

Notes: \_\_\_\_\_  
\_\_\_\_\_  
\_\_\_\_\_  
\_\_\_\_\_  
\_\_\_\_\_  
\_\_\_\_\_  
\_\_\_\_\_

4. Which questions were confusing or difficult to answer?

Notes: \_\_\_\_\_  
\_\_\_\_\_  
\_\_\_\_\_  
\_\_\_\_\_  
\_\_\_\_\_  
\_\_\_\_\_

5. What do you think about the amount it took to finish the interview ?

Y N RF DK

Notes: \_\_\_\_\_  
\_\_\_\_\_  
\_\_\_\_\_  
\_\_\_\_\_

6. Did any of the questions about your health make you uncomfortable?

Y N RF DK

Notes: \_\_\_\_\_  
\_\_\_\_\_  
\_\_\_\_\_  
\_\_\_\_\_  
\_\_\_\_\_  
\_\_\_\_\_

7. Would you have any concerns if a nurse or physician came to your home to collect a stool sample and or examine your eyes, skin or ears if you got sick after your activity at the lake or river?

Y N RF DK

Notes: \_\_\_\_\_  
\_\_\_\_\_  
\_\_\_\_\_  
\_\_\_\_\_  
\_\_\_\_\_

8. How would you feel about answering this telephone interview three times over a three week period?

Y N RF DK

Notes: \_\_\_\_\_  
\_\_\_\_\_  
\_\_\_\_\_  
\_\_\_\_\_  
\_\_\_\_\_  
\_\_\_\_\_

9. On the whole, would you be willing or interested in participating in the CHEERS study?

Y N RF DK

Notes: \_\_\_\_\_  
\_\_\_\_\_  
\_\_\_\_\_  
\_\_\_\_\_  
\_\_\_\_\_  
\_\_\_\_\_

10. If so, how much money do you think we should pay people for their time in answering the questions at the lake or river, and by phone?

Y N RF DK

Notes: \_\_\_\_\_  
\_\_\_\_\_  
\_\_\_\_\_  
\_\_\_\_\_

# **QAPP 2**

## **Appendix 8D**

### **CHEERS Pilot Study Protocol and IRB Approval Letter**

#### **Pilot Study IRB Approval Letter**

UNIVERSITY OF ILLINOIS  
AT CHICAGO

Office for the Protection of Research Subjects (OPRS)  
Office of the Vice Chancellor for Research (MC 672)  
203 Administrative Office Building  
1737 West Polk Street  
Chicago, Illinois 60612-7227

**Approval Notice**  
**Initial Review – Expedited Review**

June 22, 2007

Samuel Dorevitch, MD, MPH  
Environmental and Occupational Health  
2121 W. Taylor St.  
442 S.P.H.W., M/C 923  
Chicago, IL 60612-0690  
Phone: (312) 355-3629 / Fax: (312) 996-0064

**RE: Protocol # 2007-0420**  
**“Pilot Study for Evaluating the Chicago Water Recreation Study Field and Telephone Questionnaires”**

Dear Dr. Dorevitch:

Members of Institutional Review Board (IRB) #3 reviewed and approved your research protocol under expedited review procedures [45 CFR 46.110(b)(1) and 21 CFR 56.110(b)(1)] on June 19, 2007. You may now begin your research

**Please note, *Jacqueline Wuellner's* research training expired on 12/31/2006 and she may not participate in the conduct of the research until an amendment (adding her key research personnel) has been submitted and approved confirming that her continuing education requirement has been completed. You may refer her to the OPRS website at <http://tigger.uic.edu/depts/over/research/protocolreview/irb/education/continuing.shtml> where continuing education offerings are available."**

Your research meets the requirement(s) for the following category - Expedited Review Approval Category 45 CFR 46.110(b)(1) and /or 21 CFR 56.110(b)(1):

(7) Research on individual or group characteristics or behavior (including but not limited to research on perception, cognition, motivation, identity, language, communication, cultural beliefs or practices and social behavior) or research employing survey, interview, oral history, focus group, program evaluation, human factors evaluation, or quality assurance methodologies.

Please note the following information about your approved research protocol:

**Protocol Approval Period:** June 19, 2007 - June 17, 2008  
**Approved Subject Enrollment #:** 50

**Additional Determinations for Research Involving Minors:** These determinations have not been made for this study since it has not been approved for enrollment of minors.

**Performance Sites:** UIC

**Sponsor:** Metropolitan Water Reclamation District of Greater Chicago

**Research Protocol(s):**

- a) Epidemiologic Study of Recreational Use of the Chicago Area Waterways; March 28, 2007

**Informed Consent(s):**

- a) Chicago Water Recreation Study Pilot Consent, June\_2007

Please note the Review History of this submission :

Receipt Date	Submission Type	Review Process	Review Date	Review Action
06/13/2007	Initial Review	Expedited	06/19/2007	Approved

Please remember to:

→ Use only the IRB-approved and stamped consent document(s) enclosed with this letter when enrolling new subjects.

→ Use your **research protocol number** (2007-0420) on any documents or correspondence with the IRB concerning your research protocol.

→ Review and comply with all requirements of the, "UIC Investigator Responsibilities, Protection of Human Research Subjects"

**Please note that the UIC IRB has the right to ask further questions, seek additional information, or monitor the conduct of your research and the consent process.**

We wish you the best as you conduct your research. If you have any questions or need further help, please contact the OPRS office at (312) 996-1711 or me at (312) 355-2939. Please send any correspondence about this protocol to OPRS at 203 AOB, M/C 672.

Sincerely,

Jewell Hamilton, MSW  
IRB Coordinator, IRB # 3  
Office for the Protection of Research Subjects

Enclosure(s):

1. UIC Investigator Responsibilities, Protection of Human Research Subjects
2. Informed Consent Document(s):
  - a) Chicago Water Recreation Study Pilot Consent, June\_2007

cc: Rosemary Sokas, MD, MOH, Environmental and Occupational Health, M/C 922

# **QAPP 2**

## **Appendix 8E**

### **CHEERS Pilot Study Protocol and IRB Approval Letter**

#### **Pilot Study Protocol**

## **CHEERS Pilot Study Protocol 2007**

The procedure for the pilot field testing is outlined below:

- a. Participants will be enrolled at pre-determined sites along the Chicago River, and Lake Michigan. Three groups of participants will be enrolled: 1) recreators with water exposure at the Chicago Area Waterways (CAWs), 2) recreators with water exposure at Lake Michigan and other general use waterways, and 3) recreators without water exposure. We are interested in administering the questionnaires to specific user groups such as (but not limited to) kayakers, boaters, fishers, bikers and golfers or baseball players.
- b. Approximately 50 participants will be recruited for the pilot study over a 1 week period.
- c. CHEERS study personnel will approach individuals and explain the purpose of the pilot study. Only English speaking adults (18 years or older) will be eligible to participate in the pilot study. Interested individuals will be given a consent form to read, and ask any questions necessary for clarification.
- d. Individuals will be told that in order to participate in this pilot study they will be required to:
  - Sign an informed consent for the pilot study (Appendix A)
  - Provide an address (so their stipend can be mailed to them) and telephone number (for administering the telephone survey).
  - Complete an 8-12 minute questionnaire about their health, outdoor activities and other exposures, and provide feedback on the questionnaire. The whole process should take no more than 30 minutes.
  - Complete a 10-minute telephone questionnaire (after 1 or 2 days) about their health after the outdoor activity, and give us some feedback about the telephone questionnaire. The whole process should take no more than 30 minutes.



- Participants will be given a \$15 gift card for completing the field questionnaire and will be sent a \$10 check in the mail after completing the telephone questionnaires.
- e. Following the consent process the Field Clinical Evaluation Form (described in QAPP# 3), without the clinical assessment, Field Survey A (Appendix 5 of QAPP 2) and Field Survey B (Appendix 6 of QAPP 2) will be administered. The questionnaires will be administered by one CHEERS staff member, while a second staff member will record the process by making notes on the paper copy of the questionnaire. Questions that are followed by a long pause before the respondent provides an answer (potentially indicating difficulties in comprehension) will be noted. The observer will also note problems with questions including but not limited to wording difficulties, confusing syntax, question order, and ease of cognition. The observer will note any problems with the administration of the questionnaire, as well as any clarifications request by the participant. The administrators will also make notes of any problems after the questionnaire has been completed. The total duration of administering each survey will be recorded. The field pilot study will be conducted using paper forms or a portable computer.
  - f. After the field questionnaires are administered, the participant will be asked to evaluate any problems with the questionnaire using the field pilot survey evaluation form (Appendix B). Specific questions will be asked to direct the discussion. These questions, listed below, are not strict guidelines and should facilitate discussion of the questionnaire. Researchers will be instructed to allow subjects to converse freely about the questionnaire while covering topics of difficulty, appropriateness, and areas of potential improvement of the questionnaire.
  - g. At the end of the discussion participants will be given a \$ 15 gift card for a coffee shop or supermarket. The administrator will also make a note of the best time to call in the next two days for telephone follow-up.
  - h. A CHEERS staff member will call the participant within 2 days of their field interview. The day and time will be based on the convenience and availability

of the participant. The CHEERS member will administer a 10 minute Telephone Follow-up Interview (Appendix 7 of QAAP 2). After completing the interview participants will be asked to evaluate any problems with the questionnaire. Specific questions, outlined in the field telephone interview evaluation form (Appendix C) will be asked to prompt conversation. These questions are not strict guidelines and are designed to promote discussion of the questionnaire. Researchers will be instructed to allow subjects to converse freely about the questionnaire while covering topics of difficulty, appropriateness, and areas of potential improvement of the questionnaire.

- i. At the end of the telephone interview participants will be thanked for their time and told that a \$10 check will be mailed to them within the next 2 weeks.
- j. All data collected in the field and telephone interviews will be stored in a locked file cabinet.
- k. Evaluation of pilot data: The SPM will develop a list questions that were associated with long pauses prior to response, clarifications requested by participants, and responses to the evaluation questions that followed the administration of the questionnaires. The SPM will also meet with CHEERS personnel who conducted the pilot interviews within two days of the each interview to discuss their impressions. Following the last pilot interview, the SPM will present a summary of findings to the SRL project manager, staff who participated in the pilot, and other CHEERS key personnel. Opportunities to improve the clarity of the questionnaires, and the incorporation of new questionnaires based on respondent suggestions will be discussed.
- l. Time-table for pilot study: The pilot study will be conducted by the SPM and other CHEERS staff trained in the use of the BLAISE/CAPI software. The evaluation meeting will take place in the third week of July, and an amendment to the CHEERS study IRB protocol will be submitted listing these modifications. These changes will also be submitted to SRL for programming. These questionnaires will only be used in the field study following IRB approval.

- m. Locations: The pilots study will be conducted at various Lake Michigan and Chicago River locations. These sites and dates for conducting the pilot survey have been selected to target specific groups of recreators: for example, CAWs boaters at the Worth launch, paddlers at Clark Park, lake fishers and boaters at Jackson Park Harbor and Montrose Harbor, and lake kayakers at Wilson Beach. CAWs fishers are expected to be recruited at the River Park/Honan Park site. Unexposed recreators engaging a variety of activities are found all of the above locations.
  
- n. Human research subjects protections: All members of CHEERS pilot study team will be IRB trained/certified. The protocol will not be implemented until IRB approval is obtained (Appendix D). All hard copies of forms with identifiers will be stored in locked cabinets. All personal identifiers will be removed from the dataset and destroyed following the completion of the pilot study. Participants will not be identified individually in any of the discussions or reports of this pilot study.
  
- o. Staff: The field coordinator will have overall responsibility for identifying sites and times to start the pilot study. The SPM will be responsible for training staff to administer the questionnaire using the CAPI system, to perform the pilot study evaluation, and to record findings on the pilot study field data collection sheet. Staff members will work in groups of two or more.
  
- p. The telephone pilot survey will be conduct at UIC using a computer programmed in BLAISE for CATI, by landline telephone.

## **QAPP 2**

### **Appendix 9**

#### **CAWs Use Survey Data Sheet**

**CAWs Use Survey Data Sheet**

Page    of   

1. Location: \_\_\_\_\_

3. Start Time of observation: \_\_\_\_\_  
(AM / PM)

2. Date: \_\_\_\_\_ (MM / DD / YY)

3. CHEERS Staff Names: \_\_\_\_\_  
\_\_\_\_\_

4. Stop Time of observation: \_\_\_\_\_  
(AM / PM)

Tally of beginning of activity (launch, entry). If present at time of start of observation, then circle the tally mark.

	Boating	Canoeing	Diving/ jumping	Fishing stationary	Jet skiing	Rowing	Sailing	Swimming	Tubing	Wading	Water skiing	Other (indicate)
__:00												
__:10												
__:20												
__:30												
__:40												
__:50												

**Weather Conditions:**

- Cloud Cover       100%       50%       10%       0%
- Precipitation Present       Heavy       Light       Mist       Clear
- Precipitation 24 Hour       Heavy       Light       Mist       Clear
- Precipitation 24 Hour       Heavy       Light       Mist

## **QAPP 2**

### **Appendix 10**

#### **IRB Exemption for Use Survey**

UNIVERSITY OF ILLINOIS  
AT CHICAGO

Office for the Protection of Research Subjects (OPRS)  
Office of the Vice Chancellor for Research (MC 672)  
203 Administrative Office Building  
1737 West Polk Street  
Chicago, Illinois 60612-7227

**Exemption Granted**

June 8, 2007

Samuel Dorevitch, MD, MPH  
Environmental and Occupational Health  
2121 W. Taylor St.  
442 S.P.H.W., M/C 923  
Chicago, IL 60612-0690  
Phone: (312) 355-3629 / Fax: (312) 996-0064

**RE: Research Protocol # 2007-0386**  
**“Recreational Use Profile of the Chicago Area Waterways”**

Dear Dr. Dorevitch:

Your Claim of Exemption was reviewed on June 7, 2007 and it was determined that your research protocol meets the criteria for exemption as defined in the U. S. Department of Health and Human Services Regulations for the Protection of Human Subjects [(45 CFR 46.101(b))]. You may now begin your research

The specific exemption category under 45 CFR 46.101(b) is:

(2) Research involving the use of educational tests (cognitive, diagnostic, aptitude, achievement), survey procedures, interview procedures or observation of public behavior, unless: (i) information obtained is recorded in such a manner that human subjects can be identified, directly or through identifiers linked to the subjects; and (ii) any disclosure of the human subjects' responses outside the research could reasonably place the subjects at risk of criminal or civil liability or be damaging to the subjects' financial standing, employability, or reputation.

You are reminded that investigators whose research involving human subjects is determined to be exempt from the federal regulations for the protection of human subjects still have responsibilities for the ethical conduct of the research under state law and UIC policy. Please be aware of the following UIC policies and responsibilities for investigators:

1. Amendments You are responsible for reporting any amendments to your research protocol that may affect the determination of the exemption and may result in your research no longer being eligible for the exemption that has been granted.
2. Record Keeping You are responsible for maintaining a copy all research related records in a secure location in the event future verification is necessary, at a minimum these documents include: the research protocol, the claim of exemption application, all questionnaires, survey instruments, interview questions and/or data collection instruments

associated with this research protocol, recruiting or advertising materials, any consent forms or information sheets given to subjects, or any other pertinent documents.

3. Final Report When you have completed work on your research protocol, you should submit a final report to the Office for Protection of Research Subjects (OPRS).
4. Information for Human Subjects UIC Policy requires investigators to provide information about the research protocol to subjects and to obtain their permission prior to their participating in the research. The information about the research protocol should be presented to subjects in writing or orally from a written script. When appropriate, the following information must be provided to all research subjects participating in exempt studies:
  - a. The researchers affiliation; UIC, JBVMAC or other institutions,
  - b. The purpose of the research,
  - c. The extent of the subject's involvement and an explanation of the procedures to be followed,
  - d. Whether the information being collected will be used for any purposes other than the proposed research,
  - e. A description of the procedures to protect the privacy of subjects and the confidentiality of the research information and data,
  - f. Description of any reasonable foreseeable risks,
  - g. Description of anticipated benefit,
  - h. A statement that participation is voluntary and subjects can refuse to participate or can stop at any time,
  - i. A statement that the researcher is available to answer any questions that the subject may have and which includes the name and phone number of the investigator(s).
  - j. A statement that the UIC IRB/OPRS or JBVMAC Patient Advocate Office is available if there are questions about subject's rights, which includes the appropriate phone numbers.

Please be sure to:

→Use your research protocol number (listed above) on any documents or correspondence with the IRB concerning your research protocol.

We wish you the best as you conduct your research. If you have any questions or need further help, please contact me at (312) 355-2908 or the OPRS office at (312) 996-1711. Please send any correspondence about this protocol to OPRS at 203 AOB, M/C 672.

Sincerely,

Charles W. Hoehne  
Assistant Director, IRB # 2  
Office for the Protection of Research Subjects

Enclosure(s): None

cc: Rosemary Sokas, MD, MOH, Environmental and Occupational Health, M/C 922





## **QAPP 2**

### **Appendix 11**

# **IRB Approval for Survey Methods Protocol**

UNIVERSITY OF ILLINOIS  
AT CHICAGO

Office for the Protection of Research Subjects (OPRS)  
Office of the Vice Chancellor for Research (MC 672)  
203 Administrative Office Building  
1737 West Polk Street  
Chicago, Illinois 60612-7227

**Approval Notice**  
**Initial Review – Expedited Review**

June 26, 2007

Samuel Dorevitch, MD, MPH  
Environmental and Occupational Health  
2121 W. Taylor St.  
442 S.P.H.W., M/C 923  
Chicago, IL 60612-0690  
Phone: (312) 355-3629 / Fax: (312) 996-0064

**RE: Protocol # 2007-0436**  
**“Epidemiologic Study of Recreational Use of the Chicago Area Waterways”**

Dear Dr. Dorevitch:

Members of Institutional Review Board (IRB) #3 reviewed and approved your research protocol under expedited review procedures [45 CFR 46.110(b)(1) and 21 CFR 56.110(b)(1)] on June 22, 2007. You may now begin your research.

Your research meets the requirement(s) for the following categories - Expedited Review Approval Category 45 CFR 46.110(b)(1) and /or 21 CFR 56.110(b)(1):

- (3) Prospective collection of biological specimens for research purposes by noninvasive means.
- (7) Research on individual or group characteristics or behavior (including but not limited to research on perception, cognition, motivation, identity, language, communication, cultural beliefs or practices and social behavior) or research employing survey, interview, oral history, focus group, program evaluation, human factors evaluation, or quality assurance methodologies.

Please note the following information about your approved research protocol:

**Protocol Approval Period:** June 22, 2007 - June 20, 2008

**Approved Subject Enrollment #:** 9330

**Additional Determinations for Research Involving Minors:** These determinations have not been made for this study since it has not been approved for enrollment of minors.

**Performance Sites:** UIC

**Sponsor:** Metropolitan Water Reclamation District of Greater Chicago

**Research Protocol(s):**

- a) Epidemiologic Study of Recreational Use of the Chicago Area Waterways; March 28, 2007

**Recruitment Material(s):**

- a) "Be part of a research study about water quality and your health!" Flyer; CHEERS ver.1\_June 18, 2007

**Informed Consent(s):**

- a) CHEERS (Parental Permission), Ver. 1, June 18, 2007
- b) CHEERS (Consent), Version. 1, June 18, 2007

**Assent(s):**

- a) CHEERS\_assent\_ver.1 June 18, 2007

Please note the Review History of this submission :

Receipt Date	Submission Type	Review Process	Review Date	Review Action
06/18/2007	Initial Review	Expedited	06/22/2007	Approved

Please remember to:

→ **Use only the IRB-approved and stamped consent document(s) enclosed with this letter when enrolling new subjects.**

→ Use your **research protocol number** (2007-0436) on any documents or correspondence with the IRB concerning your research protocol.

→ Review and comply with all requirements of the, **"UIC Investigator Responsibilities, Protection of Human Research Subjects"**

**Please note that the UIC IRB has the right to ask further questions, seek additional information, or monitor the conduct of your research and the consent process.**

We wish you the best as you conduct your research. If you have any questions or need further help, please contact the OPRS office at (312) 996-1711 or me at (312) 355-2939. Please send any correspondence about this protocol to OPRS at 203 AOB, M/C 672.

Sincerely,

Jewell Hamilton, MSW  
 IRB Coordinator, IRB # 3  
 Office for the Protection of Research Subjects

Enclosure(s):

- 1. UIC Investigator Responsibilities, Protection of Human Research Subjects**
- 2. Informed Consent Document(s):**
  - a) CHEERS (Parental Permission), Ver. 1, June 18, 2007
  - b) CHEERS (Consent), Version. 1, June 18, 2007
- 3. Assent Document(s):**
  - a) CHEERS\_assent\_ver.1 June 18, 2007
- 4. Recruiting Material(s):**
  - a) "Be part of a research study about water quality and your health!" Flyer; CHEERS ver.1\_June 18, 2007

cc: Rosemary Sokas, MD, MOH, Environmental and Occupational Health, M/C 922

## **QAPP 2**

### **Appendix 12**

# **Thermal Wristband Barcoding Technology**

# Zebra Wrist Band Solutions



Web Link :<http://healthcare.infologixsys.com/products/Products/Barcode/Patient-Identification-Wristbands/Zebra-Wrist-Band-Solutions/default.asp>

A premium direct thermal wristband that provides automated ID verification for hospitals and other facilities seeking to boost efficiency and accuracy. Wrist band labels are also available with UV varnish, which provides excellent chemical resistance for printed information. Thermal wristbands are ideal for any environment where the accuracy of information is critical to providers.

Zebra wristbands and thermal printers are designed to perform together as a complete, optimal bar code wristband print solution -- ensuring the highest quality results for uncompromised patient safety. Easy to operate and load, Zebra's all-in-one solution makes it extremely simple for anyone to quickly create legible, accurate, reliable bar coded wristbands. As a result, CHEERS team members can quickly print Case ID wristbands for each subject with minimal instruction.

## Zebra Z-Band Direct Wristbands

- Direct thermal printing
- Clinically proven antimicrobial coating
- Pressure-sensitive adhesive tab
- Six color options
- Three sizes: adult, pediatric and infant

## Z-Band QuickClip Wristbands

- Direct thermal printing
- Clinically proven antimicrobial coating
- Secure, clip closure
- Antimicrobial coating
- Six color options
- Two sizes: Adult (1 3/16" x 11") and infant (1" x 7")

The Z-Band Zebra direct thermal wristbands feature an inorganic ionic silver coating that kills microorganisms that come into contact with it. As the silver ions are taken into the microorganisms, they react and bond to the cellular enzyme. This inhibits the microorganism enzyme activity and multiplication, which eliminates them.

Zebra's antimicrobial coating has been clinically proven to prevent the growth and survival of the following microorganisms on patient id wristbands:

- *S. aureus*
- *P. aeruginosa*
- *E. coli*

## Z-Band Zebra Direct Thermal Wristbands

- **Printers are easy to use:** within seconds you can print and secure the patient identification wristband.
- **Highly durable:** they're specially coated to resist water, soaps, chemicals and other elements so the printed bar codes remain crisp and scannable for up to 14 days. Zebra patient wristbands are scannable after repeated exposure to water and common solvents, including isopropyl alcohol, ethyl rubbing alcohol, Betadine, and Purell.
- Zebra patient wristbands offer superior tensile strength.
- Zebra patient wristbands are unlikely to cause skin irritation.



## **Benefits with Zebra Patient Identification**

Designed to work together to create a complete bar coded wristband solution, Zebra's direct thermal printers and Z-Band direct thermal wristbands with antimicrobial coating:

- Produce bar codes that remain legible and scannable for the duration of a subjects participation in the field surveys.
- Significantly reduce errors by automating access to accurate participant information.
- Satisfy participant safety and privacy standards set by IRB.

## **Zebra Barcode Printer - Model S4M**

- Affordable choice for high-volume wristband printing
- Full 8" wristband roll capacity
- Wide range of connectivity options

## **Zebra Barcode Thermal Printer - Model H 2824-Z**

- Economical and compact
- Print on a variety of patient id wristband types and sizes

## **QAPP 2**

### **Appendix 13**

## **Survey Methods Field Report**

**CHEERS**  
**Field Progress Report/Unusual Occurrence Report for Data Managers**

**Location:**

**Date:**

**Time:**

**Staff Members:**

**Shift 1:**

**Shift 2:**

**Data:**

Consent Forms	Field Survey A	Field Survey B

**1. Equipment and Supplies Issues: (battery/scanner issues, start up etc)**

**2. Data Transfer Issues:**

Case ID range given out today-

Laptop numbers used in the field today-

Data downloaded from all laptops: YES      NO

**3. Interviewer Issues: (absenteeism, non-compliance etc)**

\_\_\_\_\_ 'W' did not show up on time.

---

---

---

---

Was time sheet completed?    YES    NO

Was field supervisor informed about any interviewer issues?    YES    NO

**4. Participant Issues: (Lost wrist bands, incomplete surveys etc)**

**John Doe lost his wrist band. We looked up his consent form and completed survey B.**

**Case ID 200902 and 200967 did not return to complete survey B.**

**5. Site Factors: (weather, set up site etc)**

## **QAPP 2**

### **Appendix 14: Field Maps of Recruitment Areas**

# **QAPP 2**

## **Appendix 14A**

### **Maps of Recruitment Areas**

#### **Alsip Boat Launch**

## Alsip Boat Launch – CAWS

### Tent & table set-up (tack symbol):

1. Near Boat Launch and parking lot

**\*\*CAWS Use Survey Required\*\***

Mobile recruiting: See circled area for recruiting area – use mobile unit as necessary.

Site Permission: Cook County Right of Entry Agreement (in emergency about site permission, contact Vito Benignole at 708-906-1561 (cell))

Teams/Clubs: None

### General Target Participants:

- Boaters
- Fishermen
- Bikers, walkers, runners and other non-water recreators



# **QAPP 2**

## **Appendix 14B**

### **Maps of Recruitment Areas**

#### **Belmont Harbor**

## Belmont Harbor – G UW

### Tent & table set-up (tack symbol):

1. 41/N. Lake Shore to parking lot on North side of harbor
2. Belmont Ave. to parking lot on South side of harbor

Mobile recruiting: See circled areas. Mobile recruiting necessary from each tent location.

Site Permission: Chicago Park District Right of Entry Agreement. In emergency concerning park officers, contact Brian Loll, 773-761-8674 (office).

### General Target Participants:

- Boaters (not sailors)
- Fishermen
- Bikers, walkers and runners and other non-water recreators

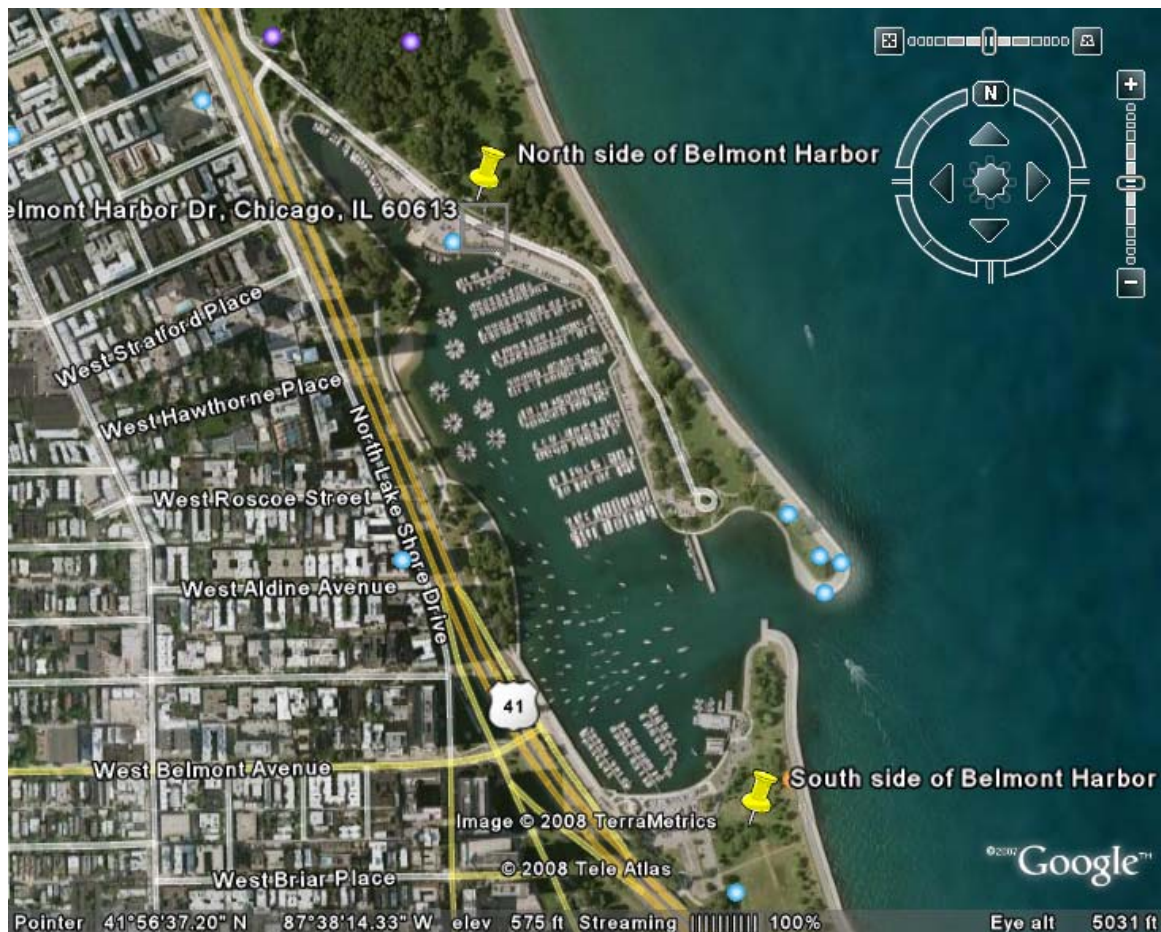



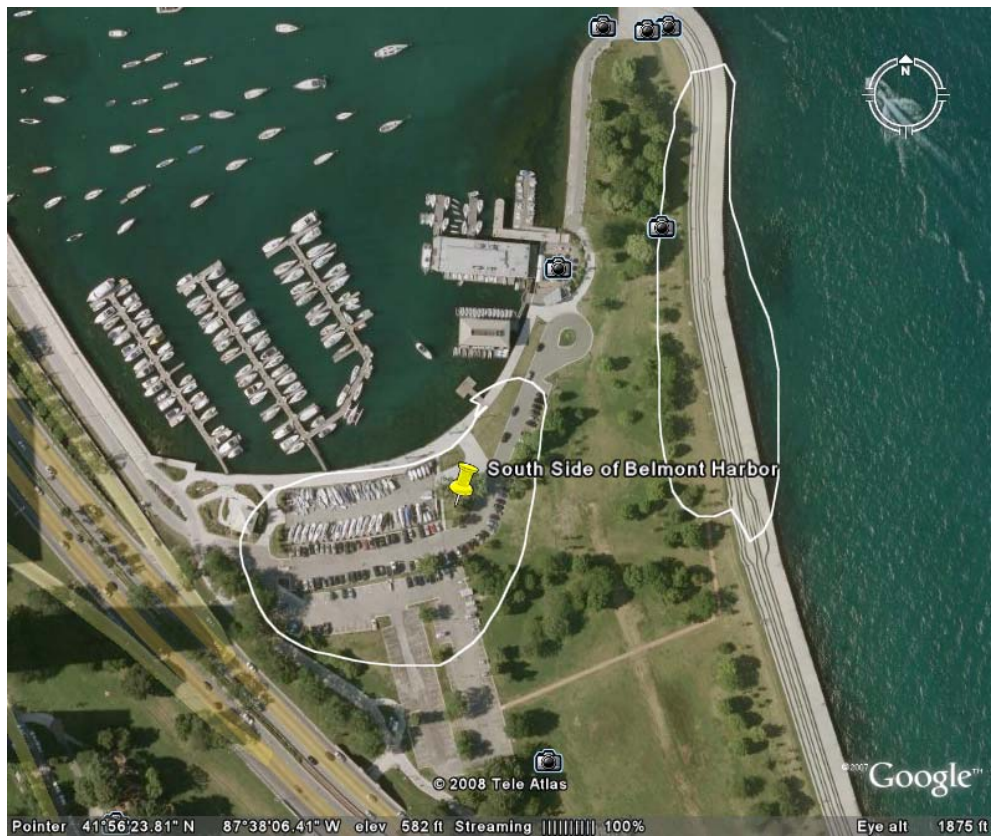

# **QAPP 2**

## **Appendix 14C**

### **Maps of Recruitment Areas**

#### **Burnham Harbor**

## Burnham Harbor - G UW

### Tent & table set-up (tack symbol):

1. Near parking lot and paths

Mobile recruiting: See circled areas. Area on other side of harbor also possibility if there are enough staff and someone is willing to walk all the way over there.

**NOTE:** Data manager – get **1** extra mobile recruiting folder from supply manager.

Site Permission: Chicago Park District Right of Entry Agreement. In emergency concerning park officers, contact Brian Loll, 773-761-8674 (office).

Teams/Clubs: None

### General Target Participants:

- Fishermen and boaters
- Bikers, runners and other non-water recreators

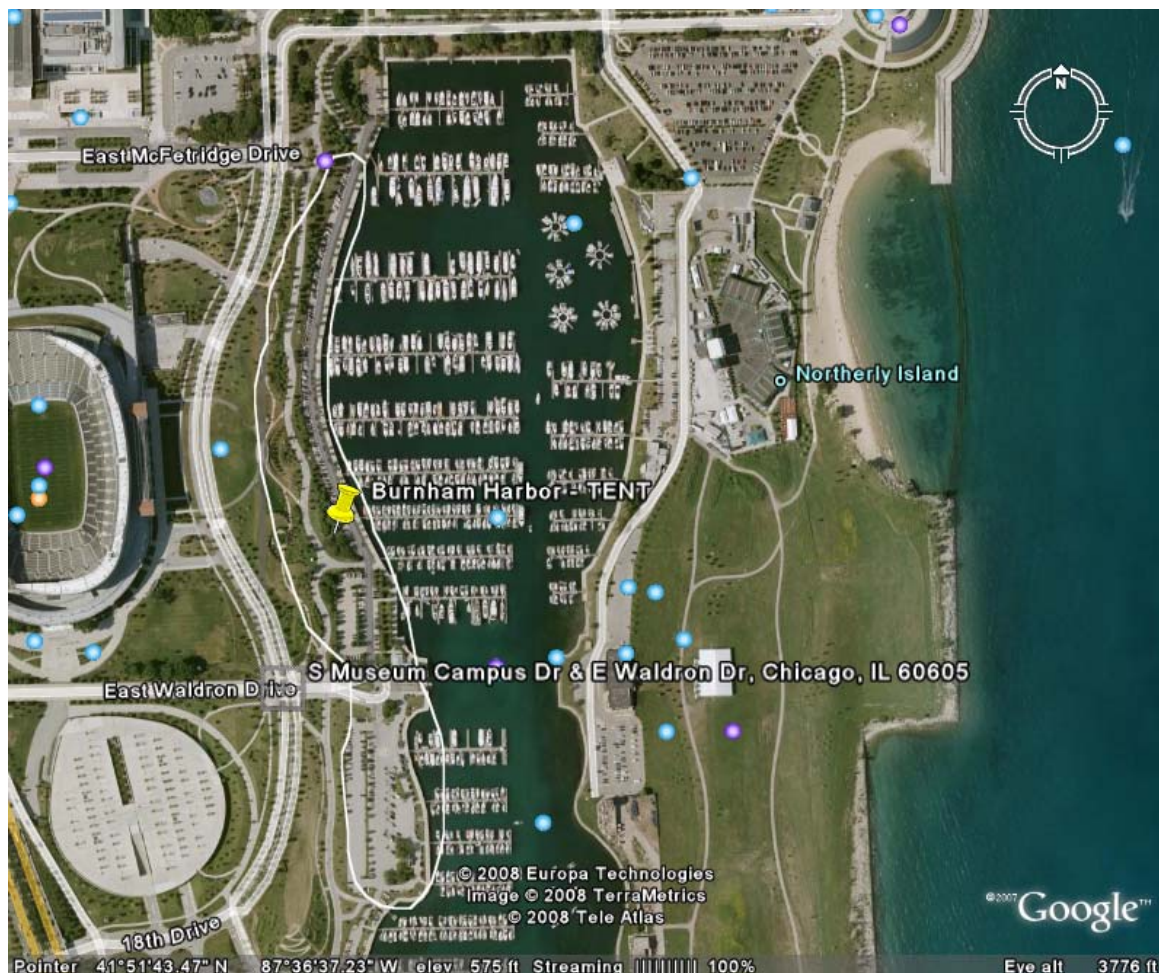

# **QAPP 2**

## **Appendix 14D**

### **Maps of Recruitment Areas**

#### **Busse Lake Boating Center**

## Busse Lake Boating Center - G UW

### Tent & table set-up (tack symbol):

1. Near boat rental facility

Mobile recruiting: See circled areas. **NOTE: Data manager – get 1 extra mobile recruiting folders from supply manager.**

Site Permission: Cook County Right of Entry Agreement (in emergency about site permission, contact Vito Benignole at 708-906-1561 (cell))

### General Target Participants:

- Boaters, paddlers and rowers
- Fishermen
- Bikers, walkers and runners and other non-water recreators

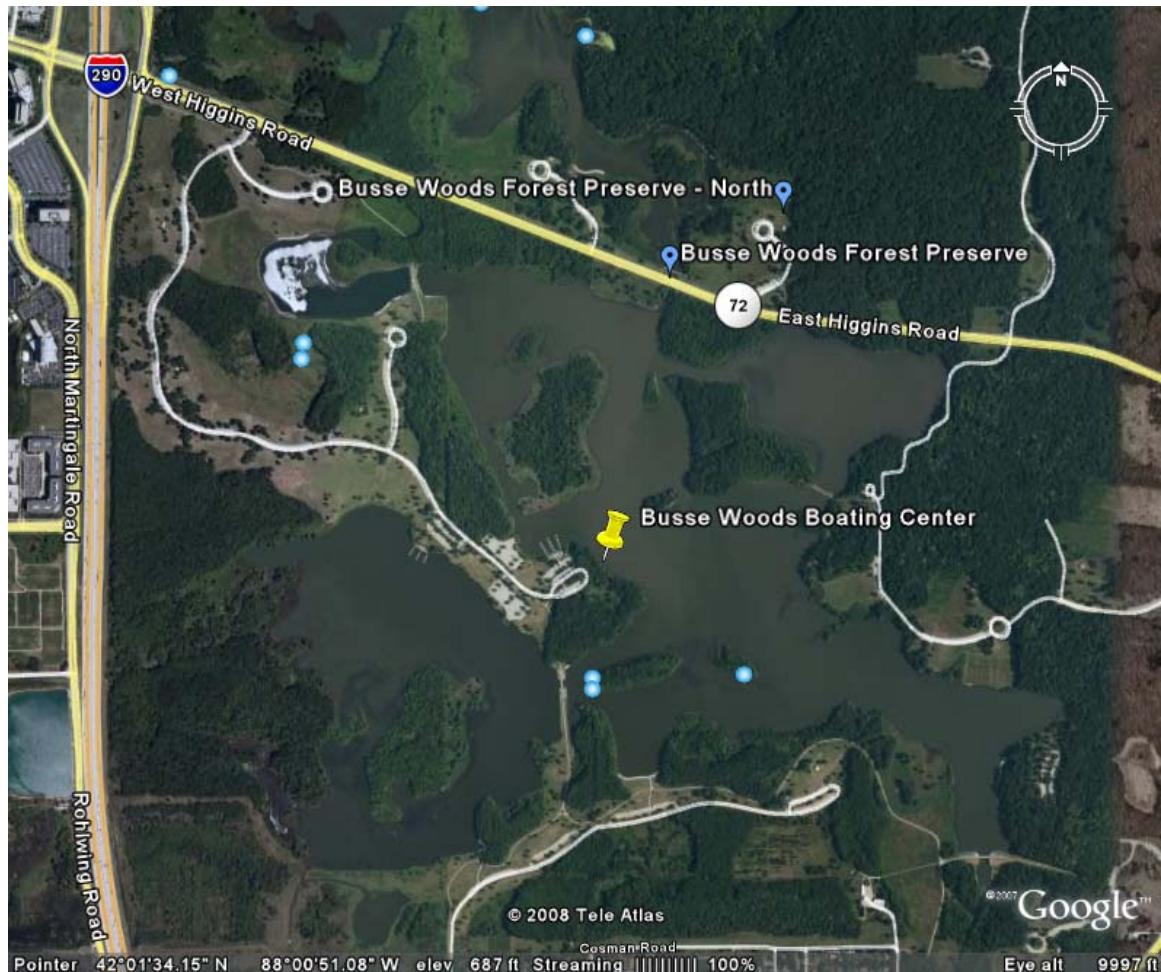



Busse Woods Boating Center

© 2008 Tele Atlas

© 2007 Google™

Pointer 42°01'26.08" N 88°01'02.24" W elev 690 ft Streaming ||||| 100% Eye alt 2340 ft

# **QAPP 2**

## **Appendix 14E**

### **Maps of Recruitment Areas**

#### **Chicago Dragon Boat Race**

## **Chicago Dragon Boat Race – CAWS**

(Ping Tom Park, 300 W. 19<sup>th</sup> St., Sat. 7/26)

### Tent & table set-up tack symbol):

1. On grass near main pavilion – location is flexible as long as it is in a visible place.

### **\*\*CAWS Use Survey Required\*\***

### Supply Manager:

**No vehicles are allowed on the park site between 7:00am - 4:00pm. All unloading of equipment by car must be done strictly before 7:00am** on the day of the races. There is only one entrance into the park and this pathway is relatively narrow. To navigate vehicles whilst there is on foot traffic has been seen in the past to be incredibly dangerous and hazardous. As a direct result of this, the Chicago Police is strongly enforcing this rule this year. In addition, on the day of the event the park is still open to the general public therefore increasing the amount of pedestrians in the park on this day. However, should you wish to unload your equipment on foot and utilize hand trolleys, you are welcome to do so. The event is scheduled to finish at approximately 4:00pm and again, no vehicles are allowed before this time.

### Parking:

In terms of parking facilities in Chinatown, there is street and metered parking as well as 2 Chinatown Parking Lots, both located on Wentworth Avenue (between 19th St. and Cermak Road). Parking between 3-12 hours costs \$16, whilst 12-24 hours costs \$25. I would strongly recommend you arrive early as possible as previous years have proven that parking fills up by 9:00am. Parking in general on most days here in Chinatown is limited, and it will be even more so on the day of the event. You have been warned!

Mobile recruiting: None. No extra mobile recruiting folders necessary.

Site Permission: Chicago Park District Right of Entry Agreement. In emergency concerning park officers, contact Brian Loll, 773-761-8674 (office), and Chicago Dragon Boat Race/ Chinatown Chamber of Commerce.

Teams/Clubs: None

### General Target Participants:

- Paddlers – **Dragon boat racers**
- Bikers, walkers, runners and other non-water recreators



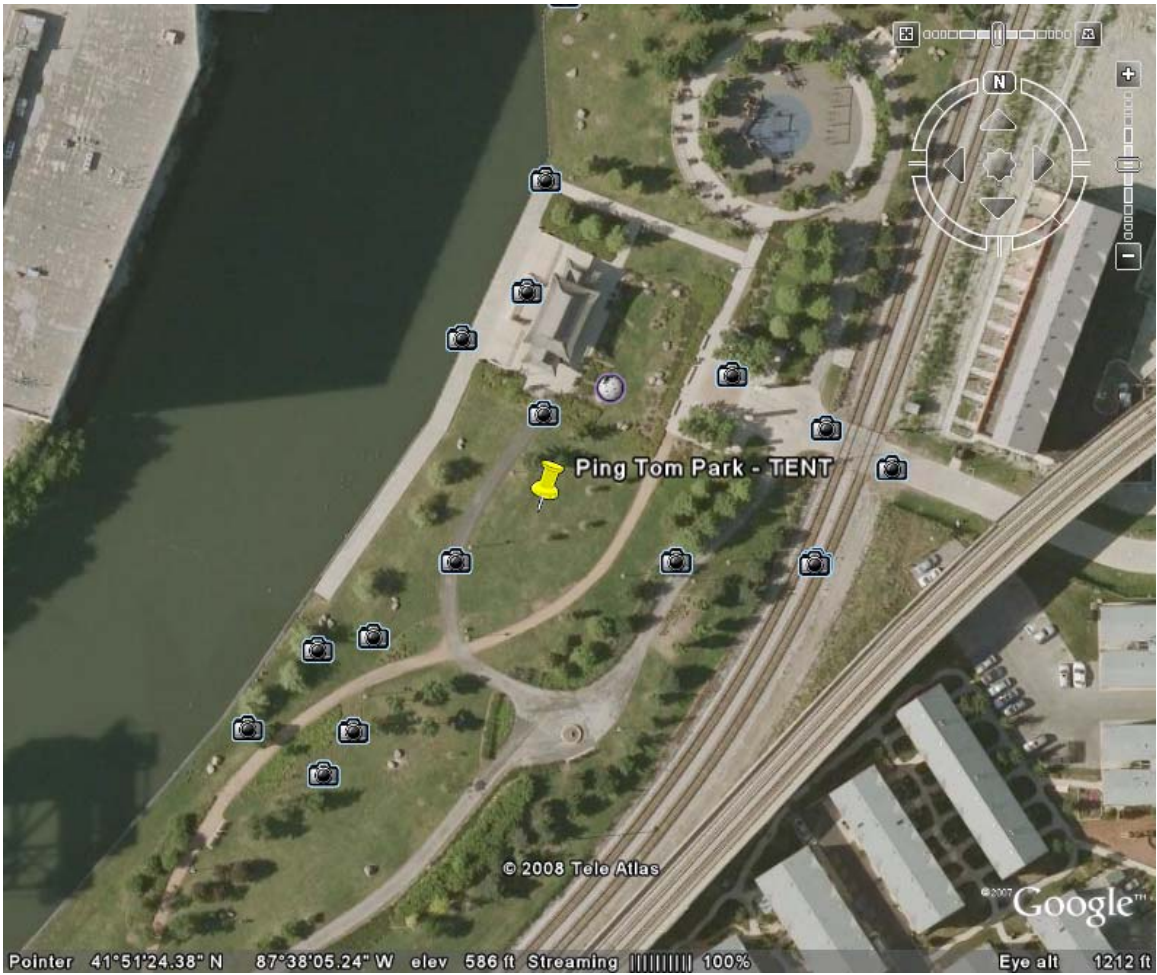

# **QAPP 2**

## **Appendix 14F**

### **Maps of Recruitment Areas**

#### **Chicago Sprints**

## **Chicago Sprints @ Lincoln Park Boat Club - G UW**

Tent & table set-up: Near registration/ check-in tent (see LPBC staff for directions).

Time: 7:30am – 7pm

Parking: Supply manager –drop off supplies and park on street, either Canon or Stockton. If you don't mind paying the zoo fees, just park in the zoo lot by the boathouse.

*NOTE: let coaches and others who check in know about the study, they'll be the ones who decide whether and when to send their athletes to you.*

Mobile Recruiting: May be useful if team members do not want to come to table.

Site Permission: LPBC – Steve Neumann

Teams/Clubs: Lincoln Park Boat Club

Target Participants:

- Rowers involved with the Chicago Sprints tournament – **BE CAREFUL with ELIGIBILITY!**
- Non water recreators in vicinity

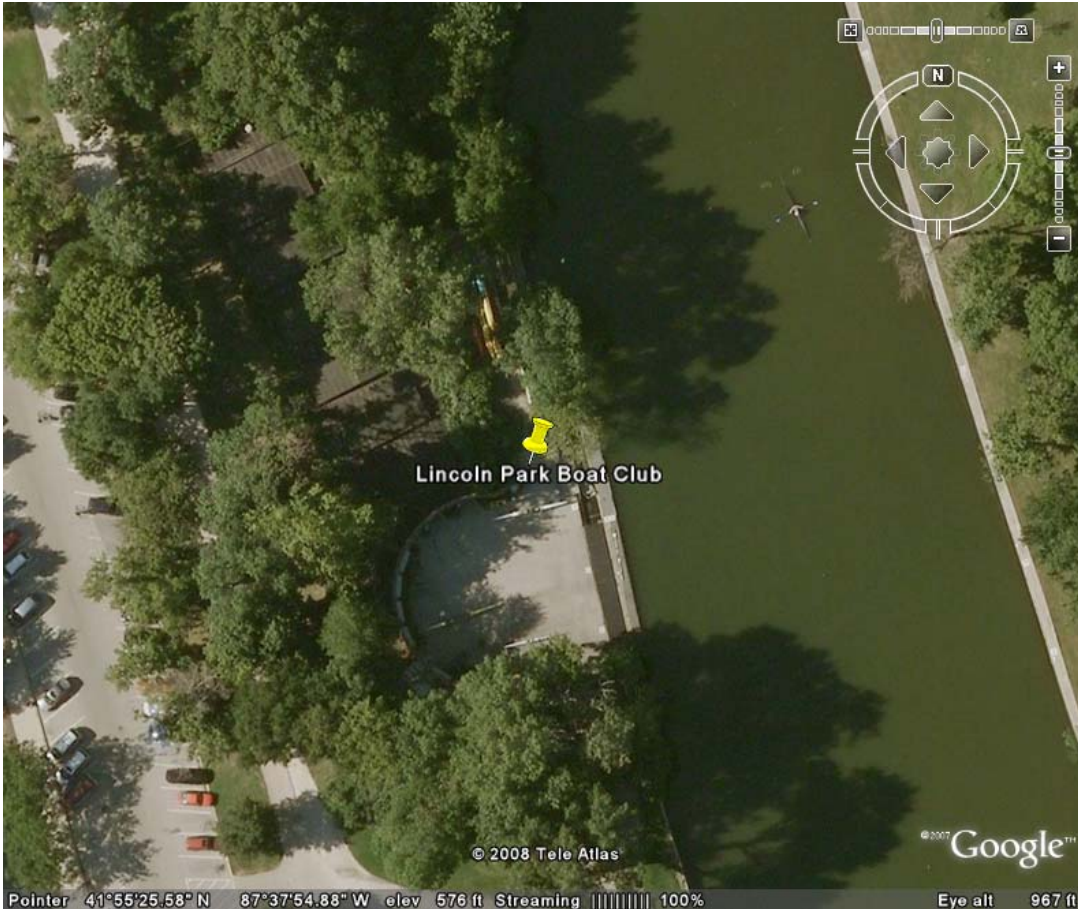

# **QAPP 2**

## **Appendix 14G**

### **Maps of Recruitment Areas**

#### **Clark Park**

**Clark Park – CAWS (3400 N. Rockwell St., Chicago IL 60618)**

Tent & table set-up **tack symbol**):

1. Near Chicago River Canoe & Kayak rental facility

**\*\*CAWS Use Survey Required\*\***

Mobile recruiting: See circled areas. No extra mobile recruiting folders necessary.

Site Permission: Chicago Park District Right of Entry Agreement. In emergency concerning park officers, contact Brian Loll, 773-761-8674 (office).

Teams/Clubs: None

General Target Participants:

- Paddlers
- Fishermen
- Bikers, walkers, runners and other non-water recreators

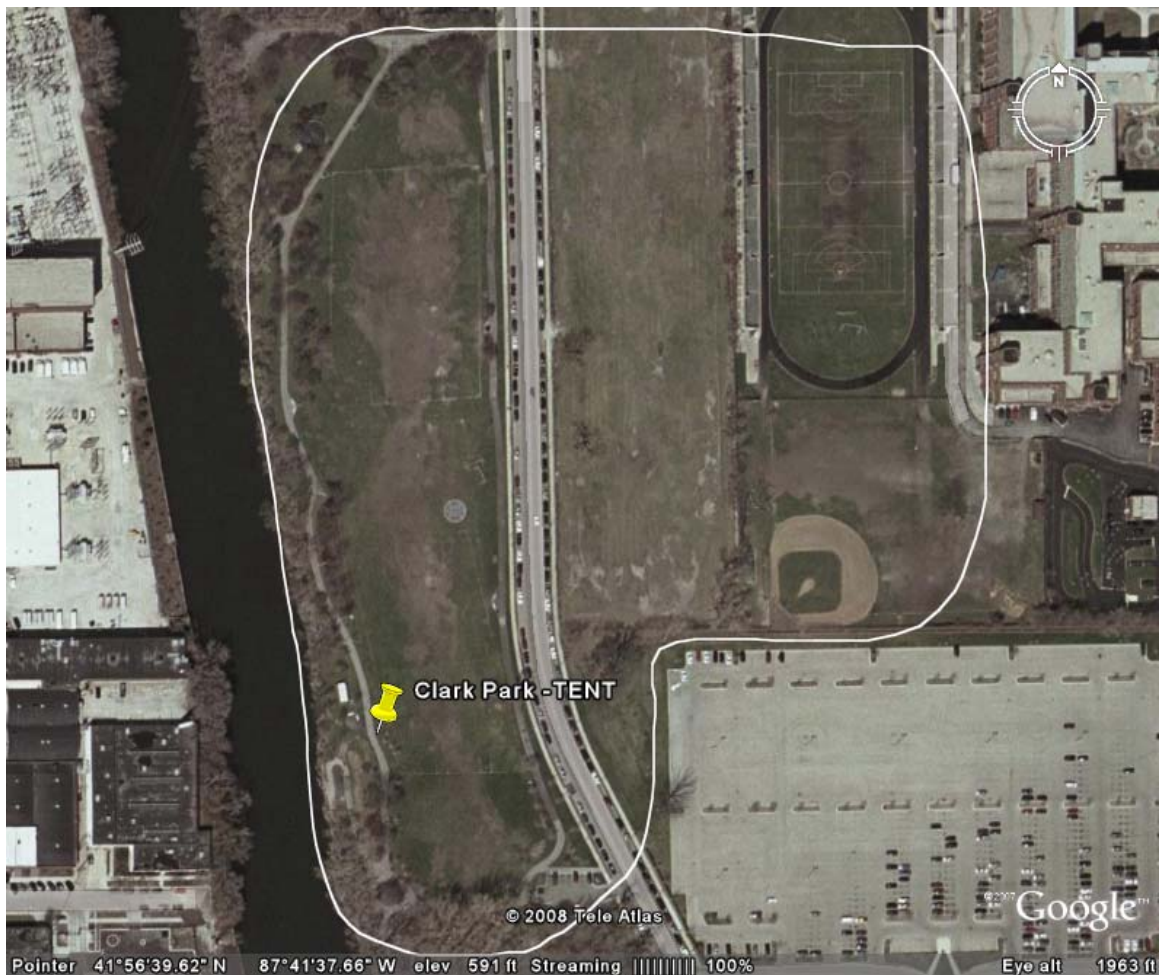

# **QAPP 2**

## **Appendix 14H**

### **Maps of Recruitment Areas**

#### **Crystal Lake**

## Crystal Lake - G UW

Recruiting sites: Boat launch

Site Permission: Crystal Lake Rowing Club, contact Arne Arnesen, (815) 356-9215.

Teams/Clubs: Crystal Lake Rowing Club – only participants recruiting.

Recruiting Method: Tent and table set-up. No mobile recruiting necessary.

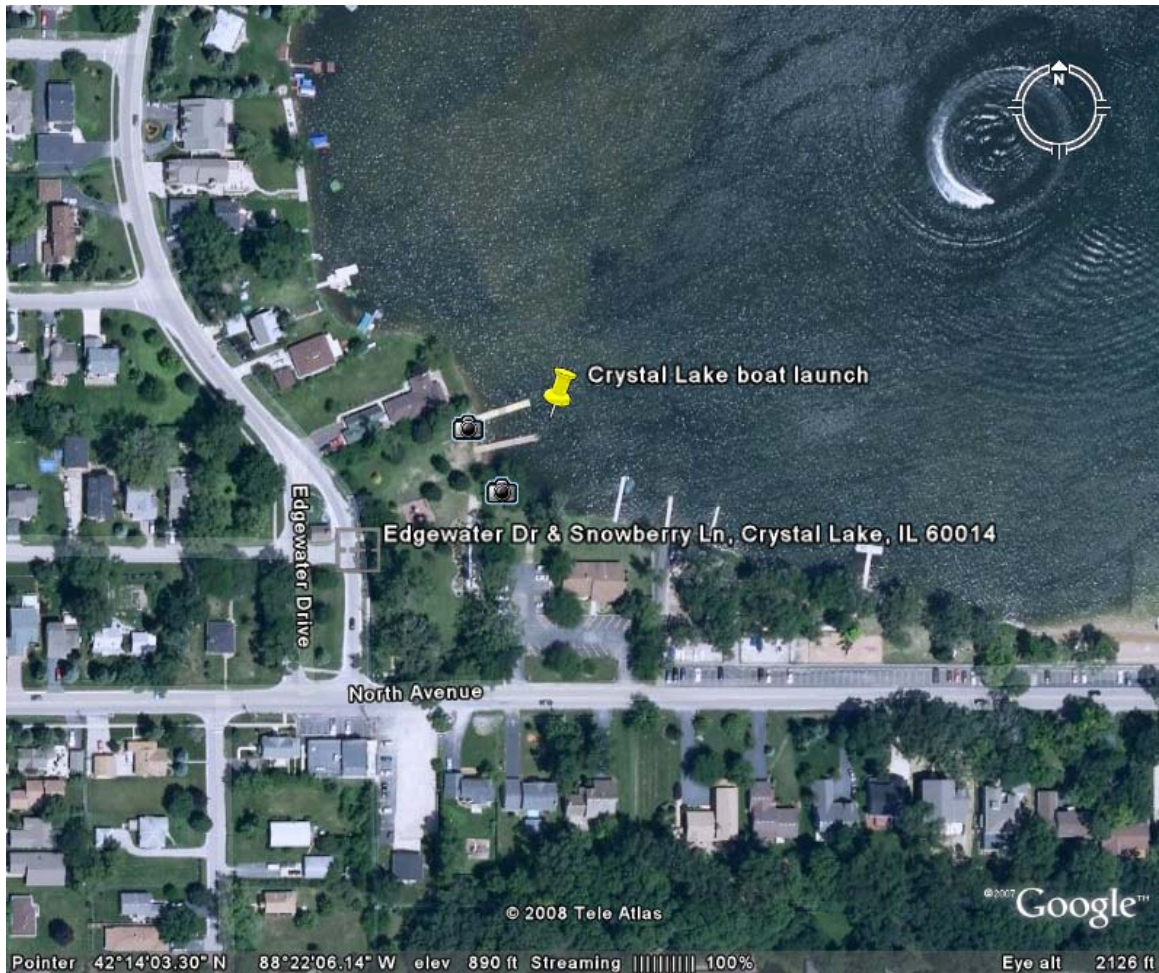



# **QAPP 2**

## **Appendix 14I**

### **Maps of Recruitment Areas**

#### **Diversey Harbor**

## Diversey Harbor - GUW

### Tent & table set-up (tack symbol):

1. Northern boat launch

Mobile recruiting: See circled areas. No extra mobile folders needed.

Site Permission: Chicago Park District Right of Entry Agreement. In emergency concerning park officers, contact Brian Loll, 773-761-8674 (office).

Teams/Clubs: none

### General Target Participants:

- Boaters (no sailboats)
- fishermen
- Bikers, walkers and runners and other non-water recreators

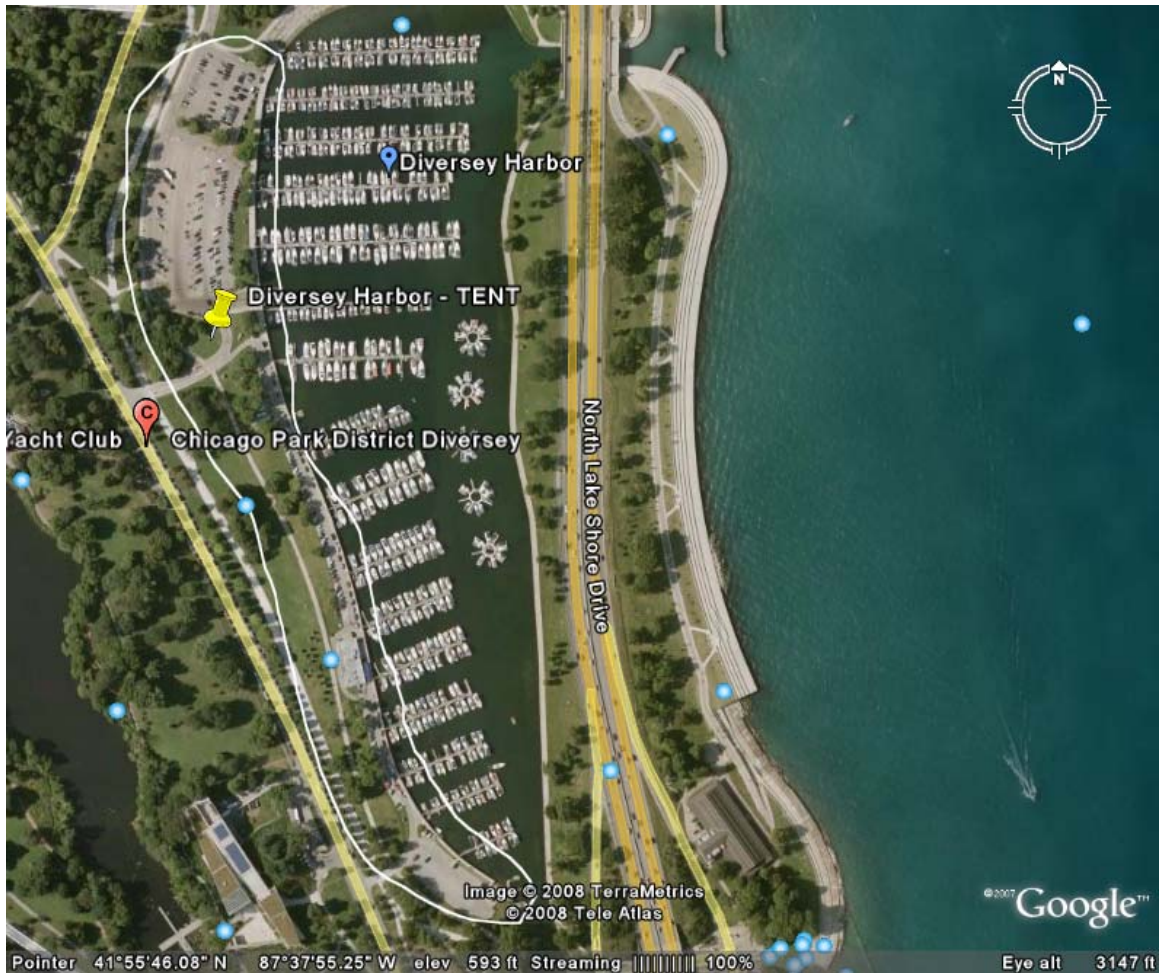

# **QAPP 2**

## **Appendix 14J**

### **Maps of Recruitment Areas**

#### **Lake Arlington**

## Lake Arlington – Sea Kayak Extravaganza - G UW

### Tent & table set-up (tack symbol):

1. In between both boat docks

Mobile recruiting: See circled area.

Site Permission: Lake County Forest Preserve Right of Entry Agreement.

Clubs/Teams: The Northwest Passage – Contact: Nancy Vedder.

### General Target Participants:

- Paddlers, rowers and boaters
- Fishermen
- Bikers, walkers and runners and other non-water recreators

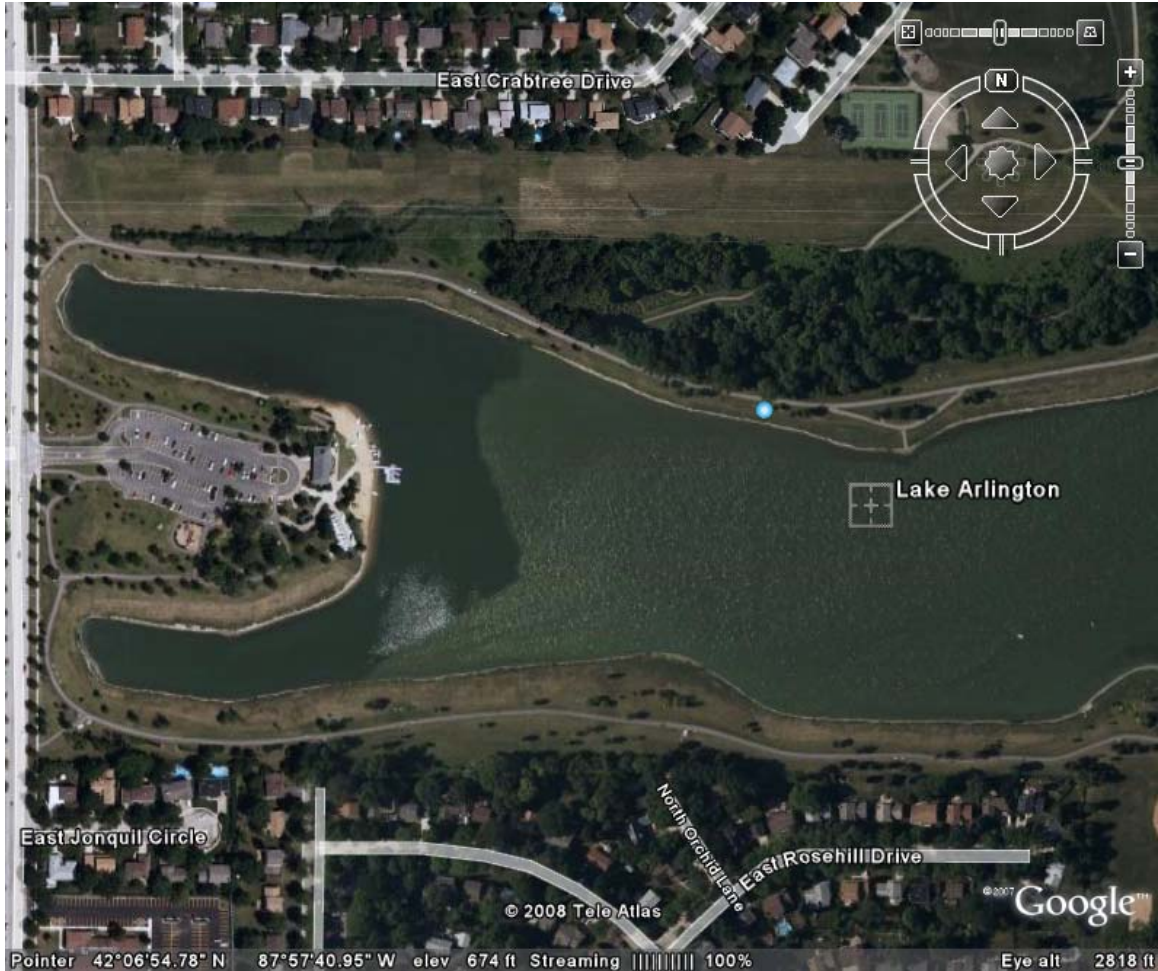



© 2008 Tele Atlas

© 2007 Google™

Pointer 42°06'54.90" N 87°57'47.86" W elev 676 ft Streaming 100% Eye alt 1123 ft

# **QAPP 2**

## **Appendix 14K**

### **Maps of Recruitment Areas**

#### **Leone Beach**

## Leone Beach - GUW

### Tent & table set-up (tack symbol):

1. Next to Kayak Chicago rental facility at beach

Mobile recruiting: At DM's discretion.

Site Permission: Chicago Park District Right of Entry Agreement. In emergency concerning park officers, contact Brian Loll, 773-761-8674 (office).

Teams/Clubs: None

### General Target Participants:

- Kayakers from **Kayak Chicago** rental facility
- Fishermen
- Non-water recreators at park south of rental facility – baseball diamonds and basketball court

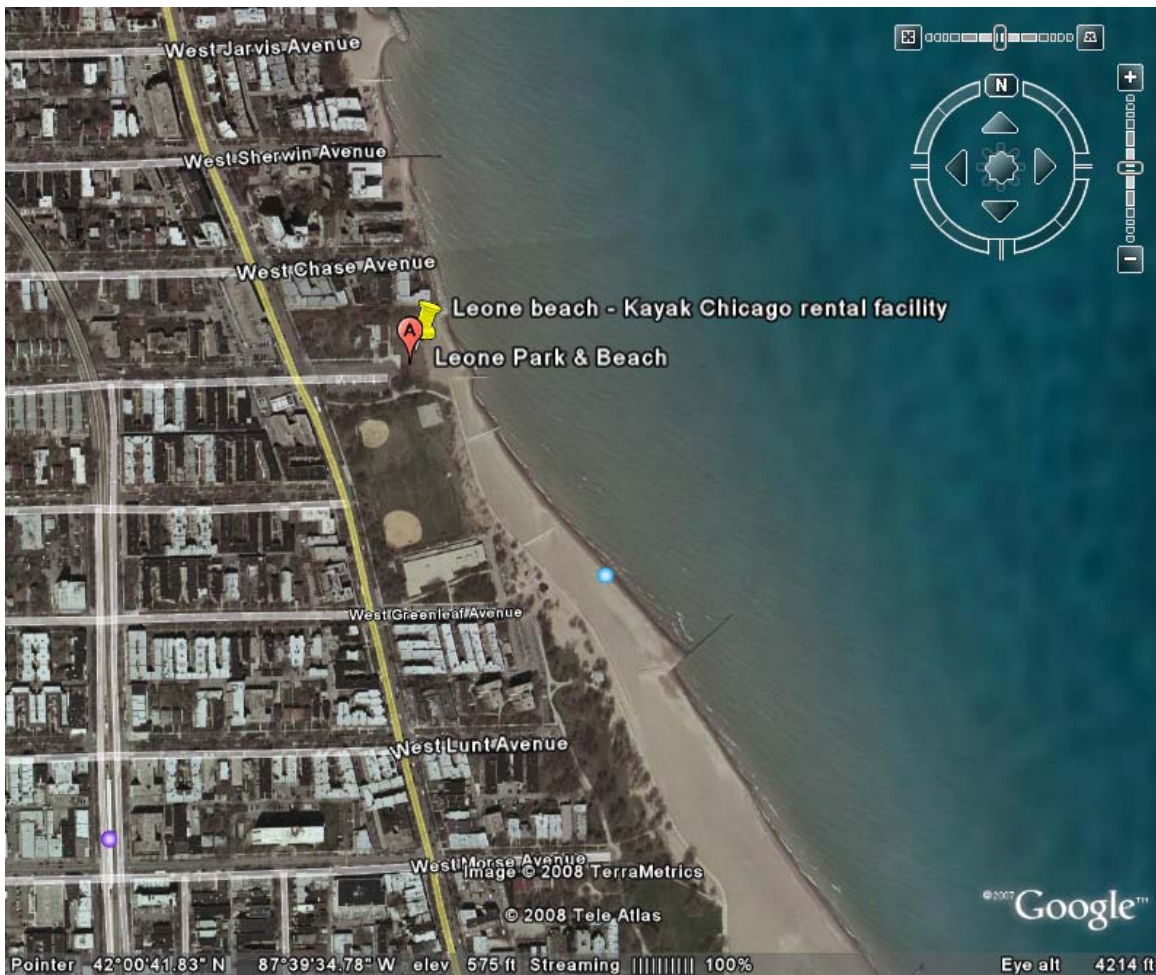





# **QAPP 2**

## **Appendix 14L**

### **Maps of Recruitment Areas**

#### **Lincoln Park Boat Club**

## Lincoln Park Boat Club - G UW

### Tent & table set-up (tack symbol):

1. Near Lincoln Park Boat Club boathouse - lagoon is between Lake Shore Drive and Cannon Dr.

Mobile Recruiting: See circled areas. No extra mobile recruiting folders necessary.

Site Permission: Chicago Park District Right of Entry Agreement. In emergency concerning park officers, contact Brian Loll, 773-761-8674 (office).

Teams/Clubs: Lincoln Park Boat Club – events, classes, recreators. Contact: Steve Neumann.

### General Target Participants:

- Paddlers and rowers at the boat club – **make sure to go through eligibility screening!!**
- Bikers, walkers, runners and other non-water recreators

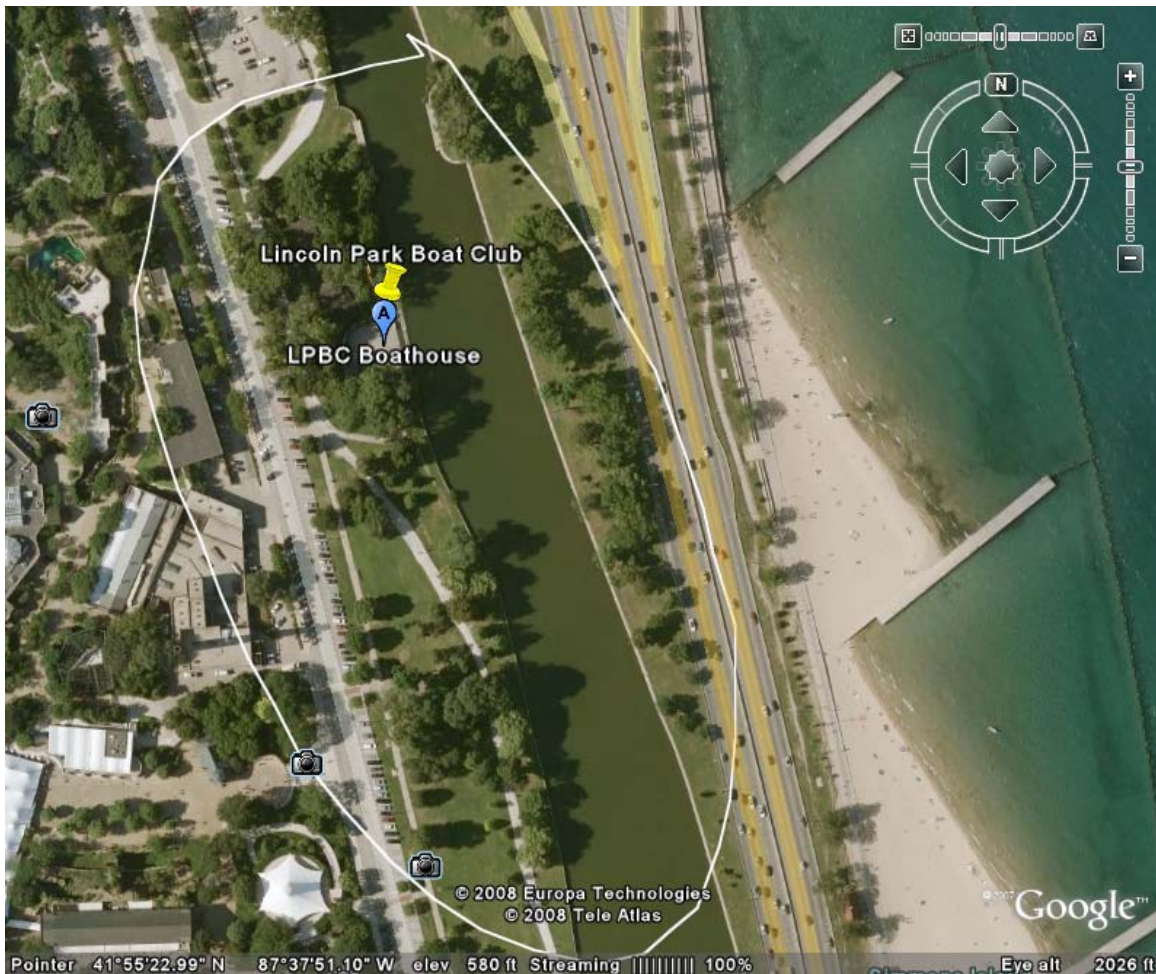



# **QAPP 2**

## **Appendix 14M**

### **Maps of Recruitment Areas**

#### **Mayor Daley's Fishing Festival**

## Mayor Daley's River Fishing Festival – CAWS

### Tent & Table set-up (tack symbol):

1. N. Columbus & East Wacker.

Directions for SM: Go Roosevelt to Columbus drive (just east of state and west of LSD). Go north on Columbus. You'll drive underground at Randolph (near Frank Ghery Band Shell), keep going north (you're now on lower columbus). Look out for 'CENTRAL AUTO POUND' signs, they will help to guide you. Pass Lake. Take a left at 'South Water'... this is where it gets tricky. You want to turn onto the part of the street that looks like a ramp heading downward (on the map it is called the 'service level' or something). Drive down the ramp. Stetson should be the next street. Take a right. You're now on the 'service level' it is one level below both lower wacker and lower columbus. Stetson deadends at the Wacker Service level. Take a right. Go straight past the Columbus service level street and head straight for the autopound at the very end of the street (if you look to your left, you'll see a gap in the concrete/fence that opens to the bikepath and a grassy knoll w/ bike rental place -- that's your goal). The street (Wacker Service level) does a U-turn @ autopound, follow the turn. Pull up in front (or near) the gap in the gate/concrete. Look for your team... unload... have a great CHEERS day.

### **\*\*CAWS Use Survey Required\*\***

Site Permission: Chicago Park District Right of Entry Agreement. In emergency concerning park officers, contact Brian Loll, 773-761-8674 (office).

Teams/Clubs: None

### General Target Participants:

- **Fishermen**
- Non-water okay but not priority

### **Mobile recruiting ESSENTIAL! DM – get 2 extra mobile folders from SM**

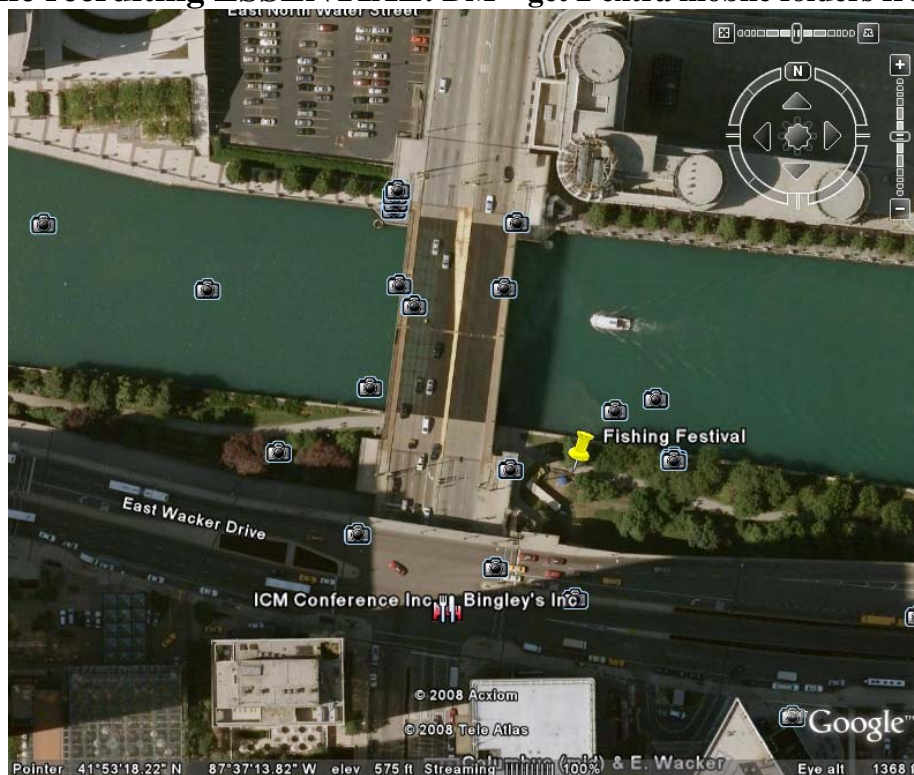

# **QAPP 2**

## **Appendix 14N**

### **Maps of Recruitment Areas**

#### **Montrose Beach**

## Montrose Beach - G UW

### Tent & table set-up (tack symbol):

1. Next to Kayak Chicago rental facility at beach
2. Near harbor – ONLY TABLES & CHAIRS IF AVAILABLE

Mobile recruiting: See circled areas. **NOTE: Data manager – get 2 extra mobile recruiting folders from supply manager.**

Site Permission: Chicago Park District Right of Entry Agreement. In emergency concerning park officers, contact Brian Loll, 773-761-8674 (office).

Teams/Clubs: None

### General Target Participants:

- Kayakers from **Kayak Chicago** rental facility
- Fishermen and boaters at north and south sides of harbor
- Bikers, runners and other non-water recreators



# **QAPP 2**

## **Appendix 140**

### **Maps of Recruitment Areas**

#### **North Ave. at Kingsbury**



## North Ave. @ Kingsbury – CAWS

### Tent & table set-up (tack symbol):

1. On pavement/sidewalk down the hill past the parking lot by Old Navy.

**\*\*CAWS Use Survey Required\*\***

Mobile recruiting: No mobile recruiting necessary. See circled area for general recruiting.

Site Permission: Private property, we're there at the invitation of the rowing club.

Contact: Mike Wallin – head coach.

### Teams/Clubs:

- Lincoln Park Juniors (LPJ)

### General Target Participants:

- Rowers on LPJ team
- Non-water recreators (sometimes rowers go to a gym to work out during practice – they are still eligible as unexposed)



# **QAPP 2**

## **Appendix 14P**

### **Maps of Recruitment Areas**

#### **North Ave. at Magnolia**

## North Ave. @ Magnolia – CAWS

### Tent & table set-up (tack symbol):

1. On pavement/sidewalk outside of kayak/rowing facility (unless otherwise given permission to come inside gates).

### **\*\*CAWS Use Survey Required\*\***

Mobile recruiting: Mobile recruiting not necessary. See circled area for general recruiting.

Site Permission: Metropolitan Water Reclamation District

### Teams/Clubs:

- Kayak Chicago – rental facility & tours (contact: Dave Olsen)
- University of Chicago
- Ignatius Chicago Crew
- Lincoln Park Boat Club men’s and women’s rowing teams (contact: Steve Neumann)

### General Target Participants:

- Rowers and paddlers
- Non-water recreators



# **QAPP 2**

## **Appendix 14Q**

### **Maps of Recruitment Areas**

#### **Skokie Lagoons**

## Skokie Lagoons - G UW

### Tent & table set-up (tack symbol):

1. Tower Rd. Boat launch

Mobile recruiting: See circled areas. No extra mobile recruiting folders necessary.

Site Permission: Cook County Right of Entry Agreement (in emergency about site permission, contact Vito Benignole at 708-906-1561 (cell))

Teams/Clubs: Chicago Kayak Club, Chicago River Canoe & Kayak, and The Northwest Passage. **NOTE: Classes given by Chicago Kayak and The Northwest Passage teach rolling/rescuing; therefore, those people are not eligible for the study.**

### General Target Participants:

- Kayakers and canoers put in at the boat launch, along with some boaters who are usually fishing off their boats.
- Fishermen need to be searched for – they are not usually near the boat launch.
- Bikers – more of a priority here than at other sites, but all non-water recreators eligible

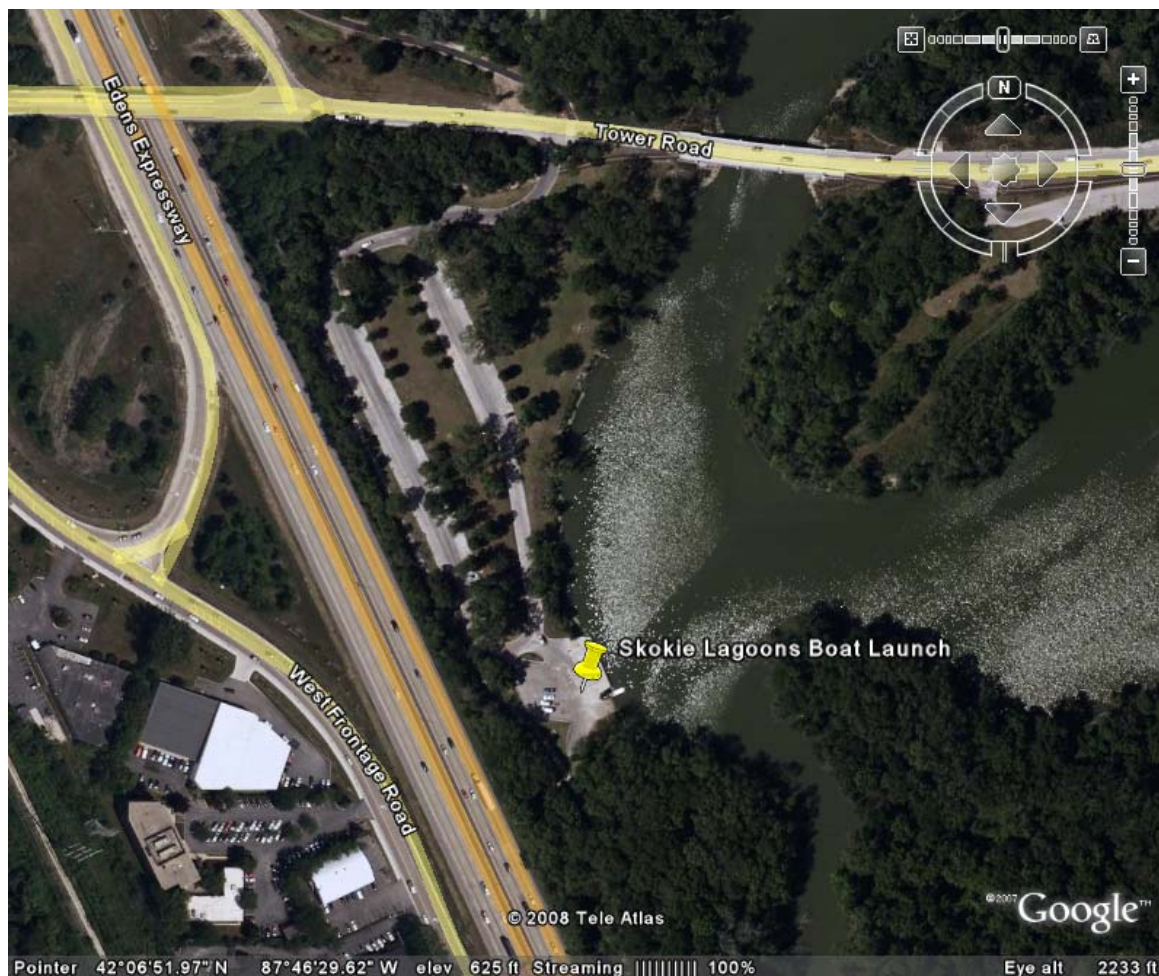

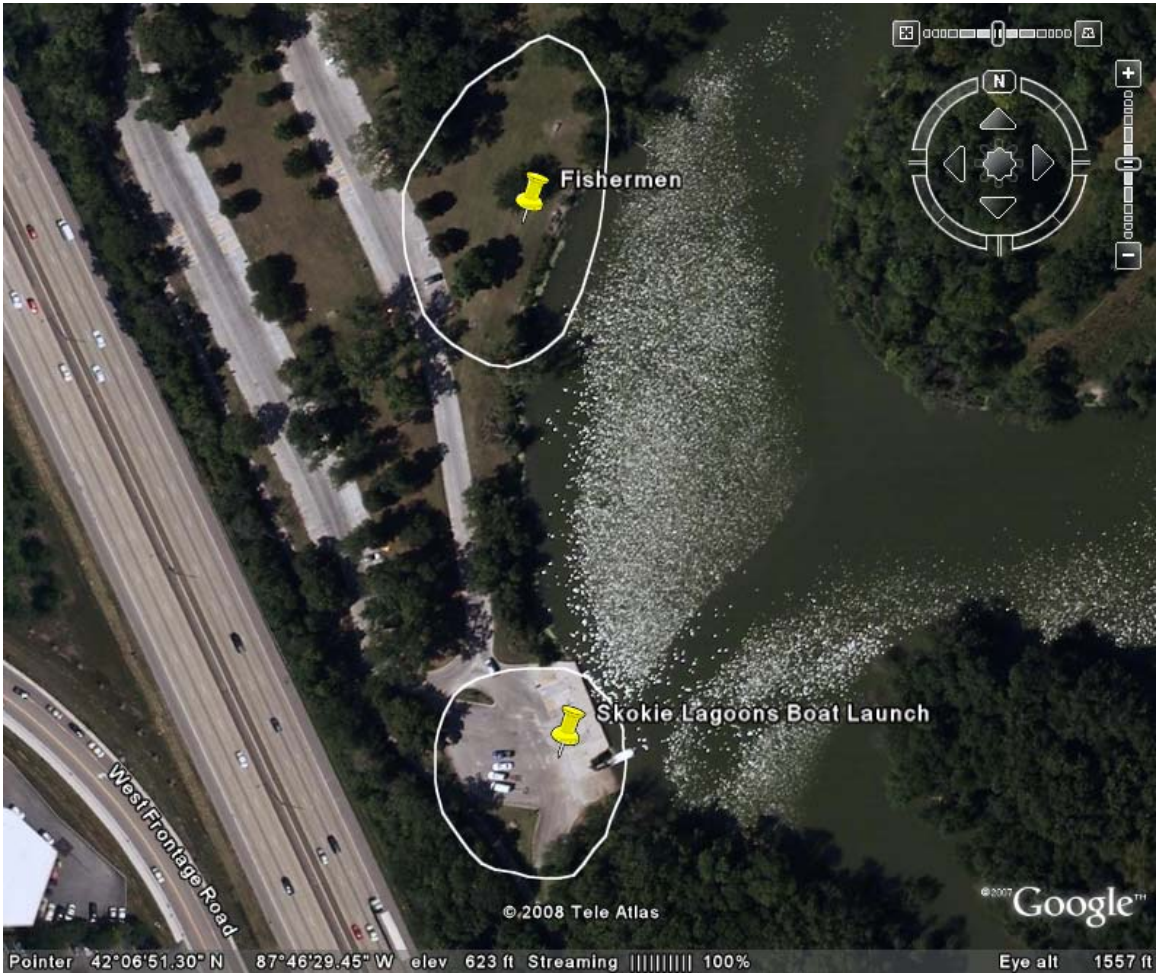

# **QAPP 2**

## **Appendix 14R**

### **Maps of Recruitment Areas**

#### **Skokie Rowing Center**

## Skokie Rowing Center – CAWS

3220 Oakton St., Skokie IL 60076 (aka Dammrich Rowing Center)

### Tent & table set-up (tack symbol):

1. Next to pavilion where Chicago R. Canoe & Kayak sets up. **DO NOT** set up under the pavilion.

### **\*\*CAWS Use Survey Required\*\***

Mobile recruiting: See circled area. No extra folders needed, but recruit non-water recreators in rest of the park north of tent.

Site Permission: Village of Skokie

### Teams/Clubs:

- Chicago River Canoe & Kayak has a rental facility (open 10am – 6pm) and hosts classes Sat. & Sun. 10am and 1pm. Contact: Ryan Chew.
- Northwestern University rowing club
- North Park University Vikings (women's crew), *note: cannot accept incentives*
- North Park University men's club
- New Trier High School Rowing
- Loyola Academy – students **DO NOT** have permission to participate in study
- Woodlands Academy – we do not have any agreement with them

### General Target Participants:

- Paddlers and rowers
- Fishermen (occasionally)
- Bikers, walkers and runners are okay but not priority.





# **QAPP 2**

## **Appendix 14S**

### **Maps of Recruitment Areas**

#### **Solidarity Drive**

## Solidarity Drive - G UW

### Tent & table set-up (tack symbol):

1. On E. Solidarity Dr. in between Aquarium and Planetarium

**OR**

2. In front of Aquarium

Mobile recruiting: See circled areas. There is a lot of ground to cover so do what you can with the staffing available.

**NOTE: Data manager – get 2 extra mobile recruiting folders from supply manager.**

Site Permission: Chicago Park District Right of Entry Agreement. In emergency concerning park officers, contact Brian Loll, 773-761-8674 (office).

Teams/Clubs: None

### General Target Participants:

- Fishermen and boaters
- Bikers, runners and other non-water recreators



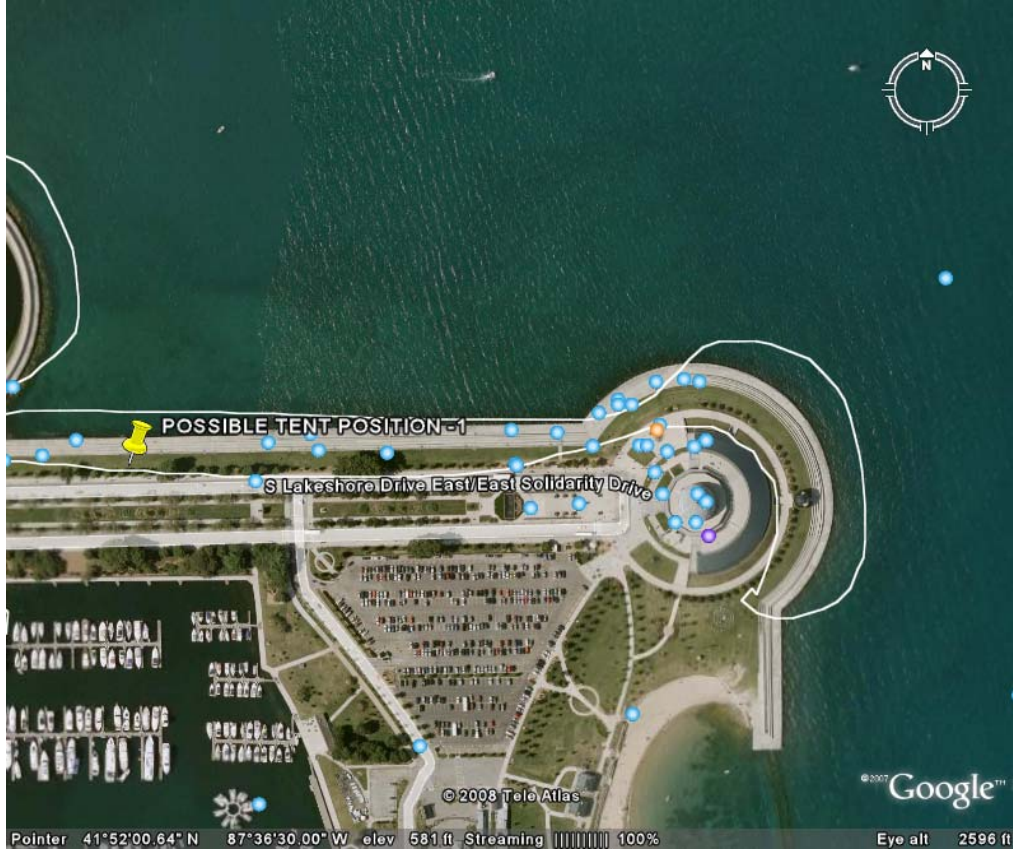

# **QAPP 2**

## **Appendix 14T**

### **Maps of Recruitment Areas**

#### **Tampier Lake**

## Tampier Lake Boating Center - G UW

### Tent & table set-up (tack symbol):

1. Next to boat launch

Mobile recruiting: See circled areas. No extra mobile recruiting folders needed.

Site Permission: Cook County Right of Entry Agreement (in emergency about site permission, contact Vito Benignole at 708-906-1561 (cell))

Teams/Clubs: None

### General Target Participants:

- Kayakers and canoers
- Fishermen and boaters
- Non-water recreators



# **QAPP 2**

## **Appendix 14U**

### **Maps of Recruitment Areas**

#### **Worth Boat Launch**

## Worth Boat Launch – CAWS

### Table & tent set-up (tack symbol):

1. Near Boat Launch

**\*\*CAWS Use Survey Required\*\***

Mobile recruiting: See circled areas. **NOTE: Data manager – get 1 extra mobile recruiting folder from supply manager.**

Site Permission: Cook County Right of Entry Agreement (in emergency about site permission, contact Vito Benignole at 708-906-1561 (cell))

Teams/Clubs: None

### General Target Participants:

- Boaters
- Fishermen by aeration SEPA site (**star marker**)
- Bikers, walkers, runners and other non-water recreators

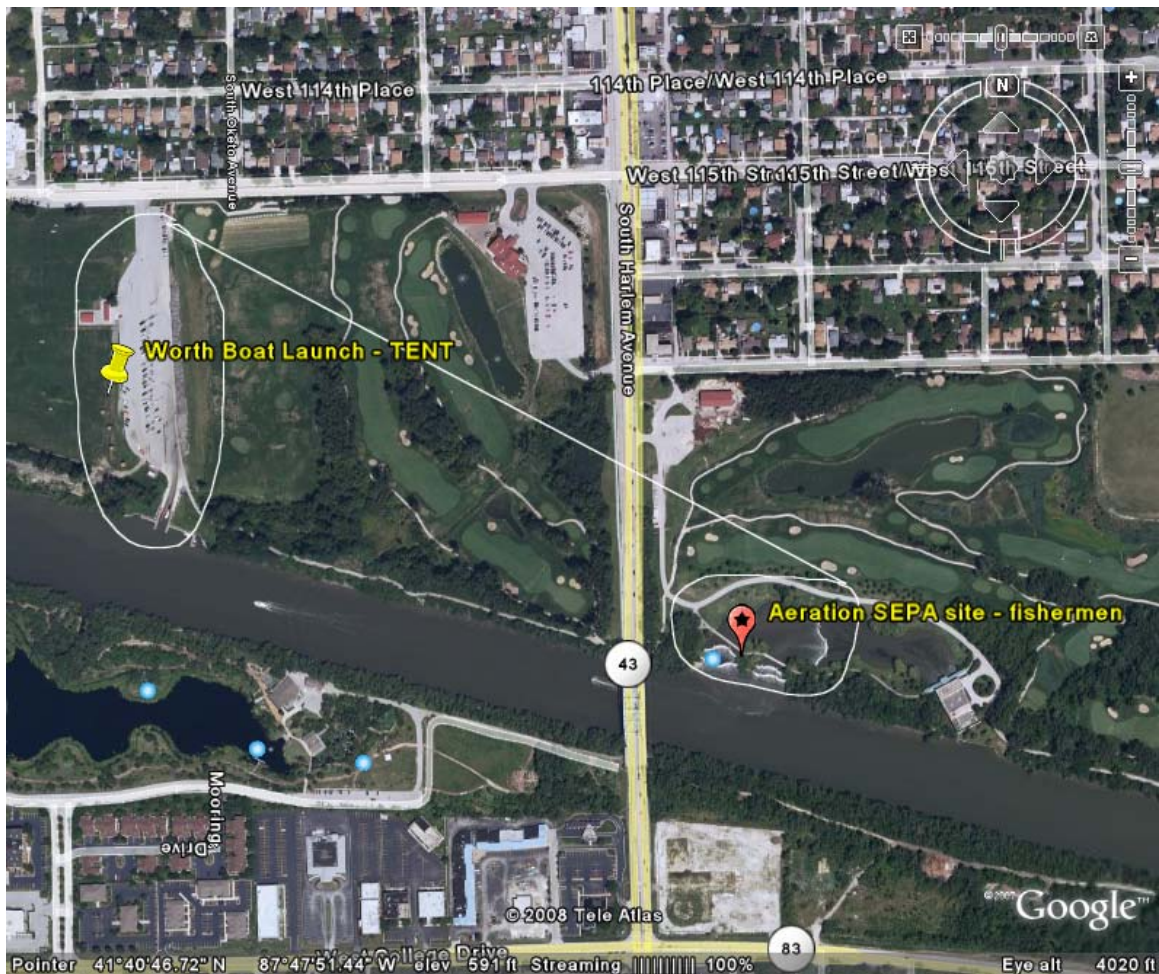





## **QAPP 2**

### **Appendix 15: Location Specific Flier for Lake**

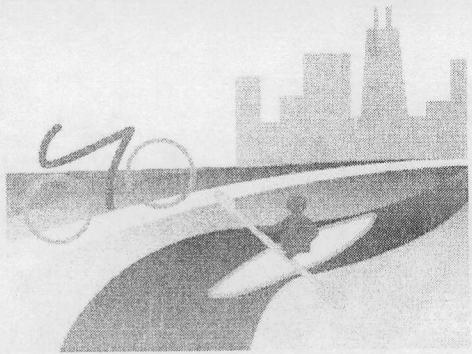

# CHEERS

WATER CHICAGO SPORTS

IRB approval box

STARTS **APPROVAL** EXPIRES

JUN 21 2008 JUN 20 2009

UNIVERSITY OF ILLINOIS AT CHICAGO  
INSTITUTIONAL REVIEW BOARD

**PLEASE NOTE: THE CHEERS STUDY IS IN PROGRESS TODAY AT THE LAKE**

As part of our efforts to improve public health, the University of Illinois at Chicago (UIC) School of Public Health is conducting a three-year study called "CHEERS," The Chicago, Health, Environmental Exposure and Recreation Study. In this study, researchers will evaluate the health of people who exercise outdoors, some who have water contact, and some who do not. This research will take place on different days, at different locations on or near Lake Michigan, the Chicago and Calumet River systems, and other rivers and lagoons in the Chicago area. **If you participate in two short survey interviews today, you will receive a \$15 gift card and a T-shirt today. After completing three 10 minute telephone follow-up interviews over the next three weeks, a check for \$35 check will be mailed to you after your last home telephone interview. If you are selected for a follow-up home visit by research nurses, you will receive a check for an additional \$75.**

**Purpose of the Survey.** Today's survey is part of a research project that will help to better understand the relationship between outdoor recreation, water quality, and, people's health. When the research project is completed, the results will help develop better guidelines for recreational water quality.

**Your Cooperation is Extremely Valuable and Will be Greatly Appreciated.** Of course, your participation in today's survey is voluntary – whether you are interviewed today is entirely up to you. All the information that you provide will be kept confidential.

**What to Expect Today.** All interviewers are wearing CHEERS t-shirts and name badges. If you are eligible, staff will interview you for about 3 minutes. The second part of the interview will be conducted after you finish your outdoor activity today. This will take about 8-10 minutes.

**When you go home.** We will contact you three times over the next three weeks, to ask you about your health. On completion of the last telephone interview, we will send you a \$35 check. If you are selected for a home visit, we may request a stool sample, or research staff may visit you at home. If you were to get sick, those results could help you and your doctor by identifying germs that may have made you ill. You would receive an additional check for \$75 for the home visit.

**Local Support for CHEERS:** Several cities, including Chicago, Evanston, Skokie, Worth, and Alsip are helping UIC with this project. For any questions call the CHEERS project coordinator at (312) 996-2094.

**WE THANK YOU IN ADVANCE FOR YOUR TIME AND COOPERATION!!**

## **QAPP 2**

### **Appendix 16: Adult Consent Form**

Leave box empty - For office use only

STARTS **APPROVAL** EXPIRES

JUL 1 2008 TO JUN 20 2009

UNIVERSITY OF ILLINOIS AT CHICAGO  
INSTITUTIONAL REVIEW BOARD

University of Illinois at Chicago  
**CONSENT FOR PARTICIPATION IN RESEARCH**

“CHEERS: The Chicago Health, Environmental Exposures and Recreation Study”

**Why am I being asked?**

The University of Illinois at Chicago (UIC) School of Public Health is conducting a research study on the health of people in the Chicago area who participate in outdoor activities. You are being asked to participate in this research study because you participate in outdoor recreational activities in and around Lake Michigan, the Chicago River, or other Chicago area waters. We ask that you read this form and ask any questions you may have before agreeing to be in the research.

Your participation in this research is voluntary. Your decision whether or not to participate will not affect your current or future relations with the University of Illinois at Chicago (UIC). If you decide to participate, you are free to withdraw at any time without affecting that relationship.

**Why is this research being done?**

We want to know if health is associated with water quality, recreation and other factors among people who participate in outdoor recreational activities in and around Lake Michigan and the Chicago River System. Results could be used for developing better environmental water quality standards to protect the health of people like you.

**What is the purpose of this research?**

The purpose of this research is to compare health risks among people who participate in different outdoor activities (including, running, biking, golfing, fishing, boating, canoeing) in and around Lake Michigan and Chicago area rivers and lakes.

**What procedures are involved?**

The research study will last about 3 years, although your participation will last about 3 weeks. Initially, you will be asked a short survey about your intended recreation today and briefly about how you are feeling and your recent activities. Continuing in the study will involve answering a series of telephone questions 2, 5 and 21 days from now.

The purpose of asking you questions is to learn more about any illness you may experience and how you were exposed. It will take 8-10 minutes or less to complete. Answering the questionnaire is voluntary. You may choose not to answer any question for any reason

In addition, some participants will be selected for a home visit by study staff. If you are selected, this could involve collecting a sample (such as a stool sample or a “pink eye” sample) so the laboratory can analyze any infection you may have. If a stool sample is required, we’ll need to collect 3 samples over a one week period. The purpose of getting stool samples is to test for bacteria, viruses, and parasites. This testing involves no risk to you. We will store your specimen indefinitely and potentially test the samples for other microbes, or for chemicals related to health or the environment, in the future.

### **What are the potential risks and discomforts?**

The research has no major physical risks or discomforts other than the time involved and the potential loss of privacy during the follow-up home visit. If you undergo the study nurse’s examination of your eyes, ears or skin, you may feel a little uncomfortable, while you are being checked. You may feel a little uncomfortable while answering certain questions during the survey/interview. You have the right to refuse to answer any questions at any time. If you are selected for a home visit, we will call to set up an appointment based on your convenience before we make the visit.

You may be concerned about how we will store/protect your data. We will do our best to protect your confidentiality and to keep the results of any test (in case we ask you for stool or eye/skin discharge samples) private. **When the results of the research are published or discussed in conferences, no information will be included that would reveal your identity.**

### **Are there benefits to taking part in the research?**

There are no direct benefits to you from being in this research. If a stool or other sample is collected, you will be notified of the results, along with advice to share those results with your physician. If you do not have a physician we will give you a directory of low cost clinics in the Chicago area. We will also provide you with information sheets about this condition.

The results from this study may or may not benefit people who participate in outdoor activities along Lake Michigan and Chicago River. Our findings could help establish a set of better water quality standards.

### **Will I be told about new information that may affect my decision to participate?**

During the course of the study, you will be informed of any significant new findings (either good or bad), such as changes in the risks or benefits resulting from participation in the research or new alternatives to participation, that might cause you to change your mind about continuing in the study. If new information is provided to you, your consent to continue participating in this study will be re-obtained.

### **What about privacy and confidentiality?**

The only people who will know that you are a research subject are members of the research team. No information about you, or provided by you during the research will be disclosed to others without your written permission, except:

- if necessary to protect your rights or welfare (for example, if you are injured and need emergency care or when the UIC Institutional Review Board monitors the research or consent process); or
- if required by law. This could happen if we collect a stool sample from you and we find that you have an infection caused by certain germs (like Salmonella and several others). We will be required by law to notify the Illinois Department of Public Health, which helps track cases of infections. The Illinois Department of Public Health will not share your personal information.

We respect your privacy. All computer files with identifiers will be password-protected. Any hard copies of the forms/files will be stored in locked cabinets and will be destroyed as soon as data collection is complete. When the results of the research are published or discussed in conferences, no information will be included that would reveal your identity.

### **What if I am injured as a result of my participation?**

No injury is expected to occur as a result of your participation in this research. In the event of injury related to this research, treatment will be available through the UIC Medical Center. However, you or your third party payer, if any, will be responsible for payment of this treatment. If you feel you have been injured, you may contact Sara Wuellner at 312-996-2094.

### **What are the costs for participating in this research?**

There are no costs to you for participating in this research.

### **Will I be reimbursed for any of my expenses or paid for my participation in this research?**

You could receive a total of up to \$125 in cash and gift cards for participating in this research according to the following schedule:

If you decide to participate, we will give you a T-shirt plus a \$15 gift card after you have answered the questions before you go home today.

Six to eight weeks after completing the three follow-up telephone interviews: \$35 (Remember the final follow-up phone call will be 3 weeks from today)

If you are selected for a home visit, after providing an eye or skin drainage swab, or 3 separate stool samples: \$75

Money will be paid in the form of a check made out to you and mailed to your home address. Alternately, if you are enrolling in the study as a member of a rowing, boating, cycling, running, or other sports team/club, you have the option to donate part or all of your compensation to the team.

### **Can I withdraw or be removed from the study?**

Your participation in this research is VOLUNTARY. If you choose not to participate, that will not affect your relationship with UIC or your right to health care or other services to which you are otherwise entitled. If you decide to participate, you are free to withdraw your consent and discontinue participation at any time without affecting your future care at UIC.

### **Who should I contact if I have questions?**

The researcher conducting this study is Dr. Sam Dorevitch. You may ask any questions you have now. If you have questions later, you may contact the researchers at: 312-996-2094.

### **What are my rights as a research subject?**

If you feel you have not been treated according to the descriptions in this form, or you have any questions about your rights as a research subject, you may call the Office for the Protection of Research Subjects (OPRS) at 312-996-1711 (local) or 1-866-789-6215 (toll-free) or e-mail OPRS at [uicirb@uic.edu](mailto:uicirb@uic.edu).

### **Remember:**

Your participation in this research is voluntary. Your decision whether or not to participate will not affect your current or future relations with the University. If you decide to participate, you are free to withdraw at any time without affecting that relationship.

You will be given a copy of this form for your information and to keep for your records.

**Signature of Subject or Legally Authorized Representative**

I have read (or someone has read to me) the above information. I have been given an opportunity to ask questions and my questions have been answered to my satisfaction. I agree to participate in this research. I have been given a copy of this form.

\_\_\_\_\_  
Signature

\_\_\_\_\_  
Date

\_\_\_\_\_  
Printed Name

\_\_\_\_\_  
Signature of Researcher

\_\_\_\_\_  
Date (must be same as subject's)

\_\_\_\_\_  
Printed name of Researcher

\_\_\_\_\_  
Signature of Witness (if appropriate)

\_\_\_\_\_  
Date (must be same as subject's)

\_\_\_\_\_  
Printed name of Witness (if appropriate)

**OPTIONAL**

I don't want to receive any money for this research. Please donate my incentives to:

- My team/club. The name of the team/club is \_\_\_\_\_
- Friends of the Chicago River
- The CHEERS research study

Signature \_\_\_\_\_

Date \_\_\_\_\_



## **QAPP 2**

### **Appendix 17: Parental Consent Form**

Leave box empty - For office use only

STARTS **APPROVAL** EXPIRES

JUL 10 2008 TO JUN 20 2009

UNIVERSITY OF ILLINOIS AT CHICAGO  
INSTITUTIONAL REVIEW BOARD

University of Illinois at Chicago  
**PARENTAL CONSENT FOR PARTICIPATION IN RESEARCH**

“CHEERS: The Chicago Health, Environmental Exposures and Recreation Study”

**Why is my child being asked?**

The University of Illinois at Chicago (UIC) School of Public Health is conducting a research study on the health of people in the Chicago area who participate in outdoor activities. Your child is being asked to participate in this research study because he/she participates in outdoor recreational activities in and around Lake Michigan, the Chicago River, or other Chicago area waters. We ask that you read this form and ask any questions you may have before agreeing to allow your child to be in the research.

Your child’s participation in this research is voluntary. Your decision whether or not to allow your child to participate will not affect your or your child’s current or future relations with the University of Illinois at Chicago (UIC). If you decide to allow your child to participate, you or your child are free to withdraw at any time without affecting that relationship.

**Why is this research being done?**

We want to know if health is associated with water quality, especially among people who participate in outdoor recreational activities in and around Lake Michigan and the Chicago River. Results could be used for developing better environmental water quality standards to protect/improve the health of people like your child.

**What is the purpose of this research?**

We want to compare health risks among people who participate in different outdoor activities (including, running, biking, golfing, fishing, boating, canoeing) in and around Lake Michigan and Chicago area rivers and lakes.

**What procedures are involved?**

The research study will last about 3 years, although your child’s participation will last about 3 weeks. Initially, you or your child will be asked a short survey about the child’s intended

recreation on the day you child enrolls in the study and briefly about how the child is feeling and their recent activities. Continuing in the study will involve you or your child answering a series of telephone questions 2, 5 and 21 days from the day your child enrolls in the study.

The purpose of asking the questions is to learn more about any illness your child may experience and how they were exposed. It will take 8-10 minutes to complete. Answering the questionnaire is voluntary. You and your child may choose not to answer any question for any reason.

In addition, some participants will be selected for a home visit by study staff. If your child is selected, this could involve collecting a sample (such as a stool sample or a “pink eye” sample) so the laboratory can analyze any infection they may have. If a stool sample is required, we’ll need to collect 3 samples over a one week period. The purpose of getting stool samples is to test for bacteria, viruses and parasites. This testing involves no risk to your child. We will store your child’s specimen indefinitely and potentially test the samples for other microbes, or for chemicals related to health or the environment, in the future.

### **What are the potential risks and discomforts?**

The research has no major physical risks or discomforts other than the time involved and the potential loss of privacy during the follow-up home visit (if your child falls ill). If your child undergoes the study nurse’s examination of his or her eyes, ears or skin, he or she may feel a little uncomfortable while being checked. Your child may feel uncomfortable while answering certain questions during the survey/interview. You and your child have the right to refuse to answer any question at any time. We will call for follow-up phone interviews at a time convenient for you and your child.

You may be concerned about how we will store/protect your child’s data. We will do our best to protect your child’s confidentiality and to keep the results of any test (in case we ask your child for stool or eye/skin discharge samples) private. **When the results of the research are published or discussed in conferences, no information will be included that would reveal your child’s identity.**

### **Are there benefits to taking part in the research?**

There are no direct benefits to your child from being in this research. If a stool or other sample is collected, you will be notified of the results, along with advice to share those results with your physician. If you do not have a physician will be given a directory of low cost clinics. You will also be given a printed fact sheet about the condition.

The results of this study may or may not benefit people who participate in outdoor activities along Lake Michigan and Chicago rivers and lakes. Our findings could help create a set of better water quality standards.

### **Will I be told about new information that may affect my/ my child’s decision to participate?**

During the course of the study, you and your child will be informed of any significant new findings (either good or bad), such as changes in the risks or benefits resulting from participation in the research or new alternatives to participation, that might cause you to change your mind about continuing in the study. If new information is provided to you, you and your child will be asked to consent again to continue participating in this study.

### **What about privacy and confidentiality?**

The only people who will know that your child is a research subject are members of the research team. No information about your child, or provided by you during the research will be disclosed to others without written permission from you, except:

- if necessary to protect his/her rights or welfare (for example, if your child is injured and need emergency care or when the UIC Institutional Review Board monitors the research or consent process); or
- if required by law. This could happen if we collect a stool sample from your child and we find that he or she has an infection caused by certain germs (like Salmonella and several others). We will be required by law to notify the Illinois Department of Public Health, which helps track cases of infections. The Illinois Department of Public Health will not share your child's personal information.

We respect your child's privacy. All computer files with identifiers will be password-protected. Any hard copies of the files will be stored in locked cabinets and will be destroyed as soon as data collection is complete. When the results of the research are published or discussed in conferences, no information will be included that would reveal you and your child's identity.

### **What if my child is injured as a result of my participation?**

No injury is expected to occur as a result of your participation in this research. In the event of injury related to this research, treatment will be available through the UIC Medical Center. However, you or your third party payer, if any, will be responsible for payment of this treatment. If you feel your child has been injured, you may contact Sara Wuellner at 312-996-2094.

### **What are the costs for participating in this research?**

There are no costs to you/your child for participating in this research.

### **Will my child be reimbursed for any of my expenses or paid for my participation in this research?**

Your child could receive a total of up to \$125 in cash and gift cards for participating in this research according to the following schedule:

If your child decides to participate, they will be given a T-shirt plus a \$15 gift card after they have answered the questions before they go home on the day they enroll in the study.  
Six to eight weeks after completing the three follow-up telephone interviews: \$35 (Remember the final follow-up phone call will be 3 weeks from the day they enroll in the study)

If your child is selected for a home visit, after providing an eye or skin drainage swab or 3 separate stool samples: \$ 75

Money will be paid in the form of a check made out to your child and mailed to your home address. Alternately, your child has the option to donate their compensation to the rowing team to which they belong, if they so desire.

### **Can my child withdraw or be removed from the study?**

Your child's participation in this research is VOLUNTARY. If you/your child choose not to participate, that will not affect your relationship with UIC or your right to health care or other services to which you are otherwise entitled. If you decide to allow your child to participate, you are free to withdraw your consent and discontinue participation at any time without affecting your future care at UIC.

### **Advance consent**

Children (and adults) can enroll in this research as often as every 21 days. Each time they would receive the same set of financial incentives (gift cards and checks). This research study will seek to recruit members of rowing teams and other sports team/clubs several times during the 2008 season. If your child is on a team/club, you can check a box on the signature page of this form, that would allow your child to enroll and re-enroll into the study when the CHEERS research staff are recruiting members of the team, even if you aren't present. You can withdraw your permission at any point by contacting the CHEERS team at (312)996-2094 or (312)355-3629.

### **Who should I contact if I have questions?**

The researchers conducting this study are Dr. Sam Dorevitch and Dr. Preethi Pratap. You may ask any questions you have now. If you have questions later, you may contact the researchers at: 312-996-2094.

### **What are my child's rights as a research subject?**

If you feel your child has not been treated according to the descriptions in this form, or you have any questions about your child's rights as a research subject, you may call the Office for the Protection of Research Subjects (OPRS) at 312-996-1711 (local) or 1-866-789-6215 (toll-free) or e-mail OPRS at [uicirb@uic.edu](mailto:uicirb@uic.edu).

### **Remember:**

Your child's participation in this research is voluntary. Your decision whether or not to allow your child to participate will not affect your current or future relations with the University. If you agree to participation, you and your child are free to withdraw at any time without affecting that relationship.

You will be given a copy of this form for your information and to keep for your records.

**Signature of Subject or Legally Authorized Representative**

I have read (or someone has read to me) the above information. I have been given an opportunity to ask questions and my questions have been answered to my satisfaction. I agree to allow my child to participate in this research. I have been given a copy of this form.

**OPTION 1**

- My child may enroll in this research whenever they are eligible.
- My child may only enroll within 21 days of the date I sign this form.
- My child may only enroll on the date I sign this form.

**OPTION 2**

I don't want my child to receive any money for this research. Please donate his/her incentive gift card and check(s) to:

- His/her team/club. The name of the team/club is \_\_\_\_\_
- Friends of the Chicago River
- The CHEERS research study

\_\_\_\_\_  
Child's Printed Name

\_\_\_\_\_  
Signature of parent or guardian

\_\_\_\_\_  
Date

\_\_\_\_\_  
Printed name of parent or guardian

\_\_\_\_\_  
Signature of Researcher

\_\_\_\_\_  
Date

\_\_\_\_\_  
Printed name of Researcher

## **QAPP 2**

### **Appendix 18: Assent Form**



University of Illinois at Chicago  
**ASSENT TO PARTICIPATE IN RESEARCH**

“CHEERS:

The Chicago Health, Environmental Exposures and Recreation Study

1. My name is \_\_\_\_\_.
2. We are asking you to take part in a research study because we are trying to learn more about the health of people (like you) who play and exercise outdoors in and around Chicago area rivers and lakes.
3. If you agree to be in this study, we will ask you a few questions today before and after your activity. We will also call you in a few days to ask you a few questions about how you are feeling. If you get sick we may come to your home to see you and collect a sample if necessary.
4. This is safe and does not put you in any danger.
5. You will learn more about how safe it is for you and your family to exercise outdoors. If you get sick, a nurse may come to your home for a quick check-up. Your family will be paid because you are in the research project.
6. Please talk this over with your parents before you decide whether or not to join the study. We will also ask your parents to give their permission for you to take part in this study. But even if your parents say “yes” you can still decide not to do this.
7. If you don’t want to be in this study, you don’t have to. Remember, being in this study is up to you and no one will be upset if you don’t want to or even if you change your mind later and want to stop.
8. You can ask any questions that you have about the study. If you have a question later that you didn’t think of now, you can call Sara Wuellner at 312-996-2094 or ask me next time.
9. Signing your name at the bottom means that you agree to be in this study. You and your parents will be given a copy of this form after you have signed it.

\_\_\_\_\_  
Name of Subject

\_\_\_\_\_  
Date

\_\_\_\_\_  
Signature

\_\_\_\_\_  
Age

\_\_\_\_\_  
Grade in School



## **QAPP 2**

### **Appendix 19: Study Questionnaire Variables for Data Analysis**

## Appendix: Questionnaire Variable for Data Analysis

### 1. Health End-points: Acute Gastrointestinal Illness

<b>Health-end points</b>
<b>AGI – Acute GI illness</b>
1. Single symptom definition: the presence of any one of the following symptoms, as determined by telephone follow-up on day 2, 5 or 21 + No symptoms at baseline.
i. Abdominal cramps or stomach ache
ii. Diarrhea
1. Any
2. $\geq 2$ bouts/24 hour
3. $\geq 3$ bouts/24 hour
iii. Nausea
iv. Vomiting
2. Syndrome definitions :
i. Any two or more of the following symptoms + No symptoms at baseline
Vomiting
Diarrhea
Nausea
Stomach ache/abdominal cramps
ii. Highly credible GI illness (HCGI): in accordance with the definition posited by Cabelli et al (1982) + No symptoms at baseline
i. vomiting, or
ii. diarrhea associated with fever, or
iii. stomach ache with fever, or
iv. nausea with fever, or
v. diarrhea with impact on daily activities
iii. EPA study GI illness definitions + No symptoms at baseline (Wade et al, 2006)
i. $\geq 3$ loose stools/24 hours, or
ii. vomiting+ stomachache, or
iii. nausea + stomachache, or
iv. nausea with impact on activity, or
v. stomachache with impact on activity

## 2. Health End-point: Ear and Eye Illness

<b>Health endpoints</b>
<b>Non-GI Illness Ear</b>
1. Single symptom definition: the presence of any one of the following symptoms, as determined by telephone follow-up on day 2, 5 or 21 + No symptoms at baseline
i. Earache or ear infection
2. Clinically proven: the presence of any one of the following symptoms, as determined by clinical evaluation during home visits (could be left or right ear for each symptom)
i. Earache or pain with traction
ii. Discharge
iii. Canal edema
iv. Canal erythema
v. Diagnosed with ear infection
vi. Antibiotic treatment
<b>Non-GI Illness Eyes</b>
1. Single symptom definition: the presence of any one of the following symptoms, as determined by telephone follow-up on day 2, 5 or 21 + No symptoms at baseline
i. Eye irritation
ii. Drainage or crusty eyes

## 3. Health End-point: Dermal

<b>Non-GI Illness Dermal</b>
1. Single symptom definition: the presence of any one of the following symptoms, as determined by telephone follow-up on day 2, 5 or 21 + No symptoms at baseline
i. Any area on the skin that are red, or sore, or draining
ii. Rash or Itchy skin
2. Clinically proven: the presence of any one of the following symptoms, as determined by clinical evaluation during home visits (could be left or right ear for each symptom)
i. Warmth around the wound
ii. Tenderness
iii. Erythema
iv. Discharge
v. Antibiotic treatment (including type of antibiotic)

#### 4. Health End-point: Upper Respiratory

<b>Health endpoints</b>
<b>Non-GI Illness Upper Respiratory Illness</b>
1. Single symptom definition: the presence of any one of the following symptoms, as determined by telephone follow-up on day 2, 5 or 21 + No symptoms at baseline
i. Sore throat
ii. Cough
iii. Cold/ Runny or stuffy nose
2. Syndrome definitions:
i. Any two or more of the following symptoms + No symptoms at baseline
Headache
Sore throat
Cough
Cold or runny or stuffy nose
Fever
Note: Only fever or headache with out any other symptoms is not considered an upper respiratory illness
ii. Respiratory illness in accordance with the definition posited by Colford et al (2007)
Cough with phlegm

#### 5. Potential Confounder and/or Effect Modifiers: Demographics and others

<b>Demographics and other</b>
1. Age
2. Gender
3. Race
4. Telephone number
5. Address
5. Distance traveled to the lake/river for outdoor activity
6. Concern about doing water sports in the Chicago River

## 6. Effect Modifiers and/or confounders: Pre-exposure Non-water-related GI factors

<b>Effect Modifiers</b>
A. Pre-exposure and health
<b>1. Non-water related GI illness exposures</b>
1. Animal contact
a. dog/cat
b. other animal (petting zoo/farm)
2. Food exposure
a. Raw shell fish
b. Raw meats
c. raw eggs
d. Store bought cold sandwich
e. Store bought cold salad
d. Fresh produce
e. Hamburger
3. Exposure to someone ill
a. at home
b. outside home
<b>2. Environmental exposures</b>
1. Recreational water exposure in past 7 days
2. Location of exposure- lake, river, beach, pool (Chicago river/lake/lagoon vs other places)
3. Get wet during water-recreational activity
1. Any part of body wet
2. Face/head wet
2. Water in mouth
3. Swallowed water
<b>3. Pre-existing health conditions</b>
1. Chronic stomach illness/GI illness
i. Crohn's
ii. Gastritis
iii. Ulcers
iv. Lactose intolerance
v. Acid reflux
vi. Inflammatory bowel syndrome
vii. Irritable bowel syndrome
viii. Other: Specify
2. Asthma/emphysema
3. diabetes
5. Antibiotic use in past 7 days
4. prone to infections
5. Average daily bowel movements

**7. Effect modifiers and/or confounders: Post-exposure Non-water related GI factors**

<b>Effect Modifiers</b>
B. Post-exposure and health
<b>1. Non-water related GI illness exposures</b>
1. Animal contact
a. dog/cat
b. other animal (petting zoo/farm)
2. Food exposure
a. Raw shell fish
b. Raw meats
c. raw eggs
d. Store bought cold sandwich
e. Store bought cold salad
d. Fresh produce
e. Hamburger
3. Exposure to someone ill
a. at home
b. outside home
<b>2. Environmental exposures</b>
1. Recreational water exposure since last contact
2. Location of exposure- lake, river, beach, pool (Chicago river/lake/lagoon vs other places)
3. Get wet during water-recreational activity
1. Any part of body wet
2. Face/head wet
2. Water in mouth
3. Swallowed water

## 8. Behavioral Predictors of Illness: Activity-based indicators of exposure

Predictors	
A. Activity 3 study groups.	
1. Water- recreational activity (exposed groups)	
1a. Type of water-recreational activity	
1b. Location for launch and exit	
1c. Duration of activity	
1d. Wet while launching OR wade while fishing	
2a. Non-water recreational activities (unexposed)	
2b. Type of non-water recreational activity	
2c. Get wet at all	
1.	Any part of body wet
2.	Face/head wet
2.	Water in mouth
3.	Swallowed water
B. Water exposure by activity	
Canoeing or Kayaking or Rowing or Rafting or boating or sailing or fishing on a boat or fishing at the pier	
a. Flip over (by accident)	
i.	How many times
ii.	How long in water
iii.	Head go under water
b. Swim (intentionally)	
i.	How long in water
ii.	Head go under water
c. Get wet at all	
1.	Any part of body wet
2.	Face/head wet
2.	Water in mouth
3.	Swallowed water
e. Food/water	
1.	ate/drank during or after activity on the water
2.	washed hands before eating
f. Rubbing of eyes with hands	
g. For fishermen	
i.	Type of bait (for handling exposure)
ii.	No: of fish 0, 1, 2,3, >3
iii.	Will they eat the fish they caught

# CHEERS: THE CHICAGO HEALTH, ENVIRONMENTAL EXPOSURE, AND RECREATION STUDY

## Quality Assurance Project Plan 3: Clinical Microbiology and Evaluations

### Title and Approval Sheet

July 29, 2008

University of Illinois at Chicago School of Public Health  
Division of Environmental and Occupational Health Sciences  
Division of Epidemiology and Biostatistics  
2121 W. Taylor, M/C 922  
Chicago, IL 60612

  
\_\_\_\_\_  
Samuel Dorevitch, MD, MPH  
Study Director

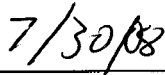
  
\_\_\_\_\_  
Date

  
\_\_\_\_\_  
Peter Scheff, PhD  
Quality Manager

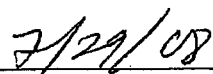
  
\_\_\_\_\_  
Date

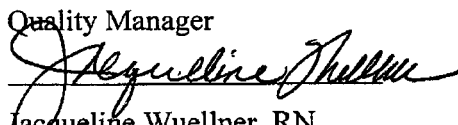
  
\_\_\_\_\_  
Jacqueline Wuellner, RN  
Clinical Project Manager

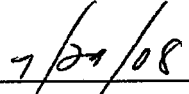
  
\_\_\_\_\_  
Date



## **Table of Contents**

<b>A. PROJECT MANAGEMENT</b>	<b><u>Page</u></b>
1. Distribution List	1
2. Project/Task Organization	1
3. Problem Definition/Background	5
4. Project Task/Description	5
5. Quality Objectives and Criteria	6
6. Special Training/Certification	6
7. Documents and Records	7
<b>B. DATA GENERATION AND ACQUISITION</b>	
1. Sampling Process Design (Experimental Design)	8
2. Sampling Methods	12
3. Sample Handling and Custody	12
4. Analytical Methods	13
5. Quality Control	15
6. Instrument/Equipment Testing, Inspection, and Maintenance	16
7. Instrument/Equipment Calibration and Frequency	16
8. Inspection/Acceptance of Supplies and Consumables	16
9. Non-direct Measurements	16
10. Data Management	17
11. Archiving Clinical Specimens	17
12. Disease Reporting	17
<b>C. ASSESSMENT AND OVERSIGHT</b>	
1. Assessments and Response Actions	18
2. Reports to Management	18
<b>D. DATA VALIDATION AND USABILITY</b>	
1. Data Review, Verification, and Validation	19
2. Verification and Validation Methods	19
3. Reconciliation with User Requirements	19

## List of Figures

<u>Figure</u>	<u>Description</u>	<u>Page</u>
Figure 1	Overall Project Management Structure for Survey Methods	4

## List of Tables

<u>Table</u>	<u>Description</u>	<u>Page</u>
Table 1	Index of Documents and Records, Storage and Distribution	7
Table 2	Index of Analytic Methods for Clinical Specimens	14

## List of Appendices

<u>Appendix</u>	<u>Description</u>
1	CHEERS Home Clinical Evaluation Form
2	Specimen Collection System
3	Letter to Study Participants
4	Conjunctivitis Rating Scale
5	Positive Culture Letter: Stool
6	Positive Culture Letter: Eye/Wound
7	Fact Sheets
8	Low Cost Clinics in Chicago
9	Chain of Custody Log
10	UIH Laboratory: Stool Culture
11A-C	UIH Laboratory: Stool Viral Culture
12	UIH Laboratory Protocol: Cryptosporidium
13	UIH Laboratory Protocol: Rotavirus
14	UIH Laboratory Protocol: Eye
15	UIH Laboratory Protocol: Wound
16	IDPH Laboratory Protocol: Shigatoxin
17	IDPH Laboratory Protocol: Norovirus
18	UIH Laboratory Details
19	UIH CLIA Certification
20	IDPH CLIA Certification
21	IDPH QA
22	UIH Laboratory Protocol: Archiving Samples and Long-term Storage
23	IDPH Laboratory Protocol: Archiving Samples and Long-term Storage
24	Unusual Occurrence Log

## **Quality Assurance Project Plan 3: Clinical Evaluations and Microbial Analyses**

### **A. PROJECT MANAGEMENT**

#### **1. Distribution List**

UIC: S. Dorevitch, P. Scheff, M. Javor, P. Pratap, J. Wuellner, S. Wuellner,  
T. Schoonover and all clinicians  
MWRDGC: T. Granato

#### **2. Project/Task Organization**

The key members of the CHEERS study team involved in the clinical evaluations and microbial analyses include the Study Director, Quality Manager, Clinical Project Manager as well as the clinical staff. The Study Director will have overall authority for the development and implementation of the study, hiring of clinical staff involved in assessments and obtaining biologic samples for analyses, and communicating with CHEERS study stakeholders. The Quality Manager will establish overall data quality objectives for the CHEERS study and will be responsible for reviewing the quality control data of the data collection process. The detailed organizational structure is provided in the Study Overview.

The Clinical Project Manager (CPM), Jacqueline Wuellner, MPH, RN, is responsible for maintaining the overall quality of the clinical evaluations and specimen collection. The Project Manager is responsible for the following project related tasks:

- 2.1 Assist in writing the application to University of Illinois at Chicago (UIC) Institutional Review Board (IRB) for Human Subjects Research approval.
- 2.2 Develop protocols for obtaining and transporting clinical specimens.
- 2.3 Work with the University of Illinois Hospital (UIH) Microbiology Laboratory and the Illinois Department of Public Health (IDPH) Microbiology Laboratory to ensure proper protocols for specimen chain of custody are followed.
- 2.4 Ensure all clinical team members performing home visits to obtain culture specimens are certified (and maintain certification) by the UIC IRB.

- 2.5 Work with the Study Director to develop and conduct the appropriate training methods for the clinical team.
- 2.6 Work with the UIC Survey Research laboratory (SRL) to identify all study participants from whom clinical specimens are required for culture.
- 2.7 Work with a commercial courier service to ensure the prompt transport of stool specimens from the home of the study participant to the UIH Microbiology Lab.
- 2.8 Train staff how to prepare for shipping Fisherbrand Commode Specimen Collection kits (Fisher Health Catalog # 02-544-208) with instructions for use to study participants identified during telephone interviews as candidates for stool sample analysis.
- 2.9 Ensure that clinical specimens are archived for potential future analysis at the IDPH microbiology lab.
- 2.10 Ensure that pathogens isolated in the UIH microbiology lab are archived for potential future analysis.
- 2.11 Ensure all clinical team members are trained in assessment techniques and proper specimen handling techniques before they begin working in the field.
- 2.12 Ensure availability of stool collection kits for distribution as needed.
- 2.13 Ensure all study participants are mailed project reminders within 5 days of enrollment to promote phoning the CHEERS study nurse if gastrointestinal, eye or skin symptoms develop at anytime during the 21-day active study period.
- 2.14 Implement adequate quality control methods to ensure accurate documentation of clinical data and home visit data.
- 2.15 Work with the Survey Project Manager to ensure smooth flow of participants through the phases of field, phone and clinical data collection.
- 2.16 Receive and properly store laboratory reports from the UIH Microbiology laboratory and IDPH microbiology laboratory.
- 2.17 Notify the study participant by telephone within 24 hours of receipt of positive results and provide via U.S. Postal Service health information sheets specific to the participant's infection.
- 2.18 Provide a directory of low-cost clinics to study participants who do not have a personal health care provider as needed.

2.19 Provide timely feedback and reports to the CHEERS Study Quality Manager and Study Director throughout the clinical data collection process.

The clinical staff will be responsible for completing home visits to collect the appropriate specimens from those participants reporting eye drainage, wound drainage, or redness. During the home visit, the clinician will complete an assessment, document findings and obtain any clinical specimens required. Further staff duties include arranging home visits with participants as required, transporting specimens to the UIC microbiology laboratory, and communicating with the Clinical Project Manager daily, following any home visits completed the previous evening. Also, the clinical staff will maintain an unusual occurrence log to document and communicate any unexpected events that arise during a home visit.

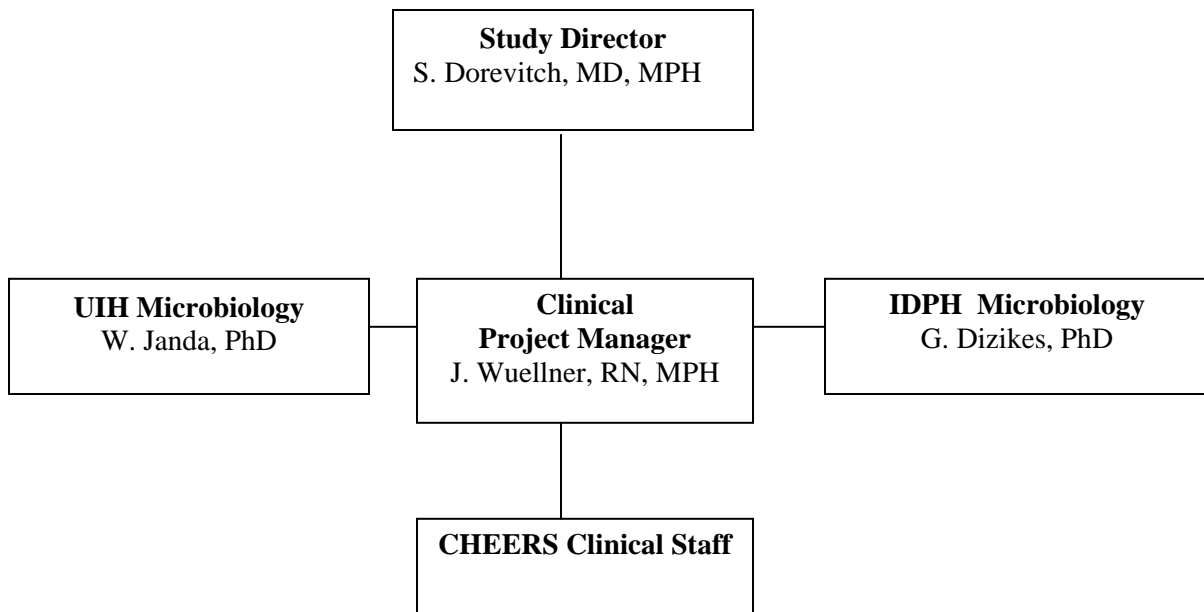

**Figure 1:** Overall Project Management Structure for Clinical Evaluations and Microbial Analyses

### **3. Problem Definition/Background**

The overall scientific background and goals of the CHEERS study are outlined in the Study Overview. The following sections will focus on development and implementation of the CHEERS clinical data collection and microbial analyses methods.

Problems specifically related to clinical evaluations and microbial analyses are:

- 3.1 Prior studies of recreational waterborne illness generally did not confirm acute gastrointestinal illness and other infectious diseases by culture.
- 3.2 Prior studies had no basis for identifying the pathogens responsible for illness among recreators.

### **4. Project/Task Description**

The overall clinical project objectives are:

- 4.1 Develop CHEERS home visit clinical evaluation forms.
- 4.2 Ensure all clinicians are licensed health care professionals.
- 4.3 Develop a system for specimen collection from study participants and document specific clinical findings at the time the culture specimen is obtained.
- 4.4 Provide specific training to clinical staff to evaluate conjunctivitis using the conjunctiva grading scale, and assess as well as measure skin lesions.
- 4.5 Train all clinical staff how to collect, label and transport a biologic specimen, maintaining sample integrity at all times.
- 4.6 Perform follow-up home visits and sample collection as per protocol based on participants' answers to the follow-up telephone surveys.
- 4.7 Contract with courier service to pick up stool specimens from participants' homes as needed and deliver the samples to UIC microbiology lab.
- 4.8 Work with the UIH and IDPH labs to develop a system to deliver and record biologic specimens collected, and maintain a record of all results.
  - 4.8.1 List of microbes of interest that we will be able to identify



Bacteria: *Salmonella*, *Shigella*, *Yersinia*, *Plesiomonas*,  
*Campylobacter*, *Aeromonas*, *Edwardsiella*, *E. Coli* 0157:H7  
Virus: norovirus, rotavirus, enteric adenovirus, enterovirus  
Parasites: *Cryptosporidium spp.*, *Giardia lamblia*, *Cyclospora*,  
*Entamoeba histolytica*

## **5. Quality Objectives and Criteria**

- 5.1 Provide stool specimen collection kits to participants identified on follow-up survey as needing such an evaluation, within 24 hours.
- 5.2 Transport 90% of stool samples to the UIH laboratory within 8 hours of sample collection.
- 5.3 Make telephone contact with participants potentially requiring home visits for evaluations of eye and skin symptoms, within 12 hours of notification by SRL that a home visit may be warranted, based on participants' symptoms.
- 5.4 Require 100% accuracy in sample handling/labeling/transport and receipt in lab. The Clinical Project Manager will train all clinical staff in proper handling and labeling of specimens and will maintain an unsatisfactory specimen log to assure immediate correction of problems/inconsistencies.
- 5.5 Conduct consistent clinical assessments among clinical personnel.

## **6. Special Training/Certification**

All clinical personnel will be licensed health professionals and therefore, will only require specific training focused on documenting conjunctivitis using the conjunctiva grading scale, and assessing and measuring skin lesions for accuracy and consistency. Training will be conducted using didactic and interactive teaching methods. Members of the clinical team will be required to verbalize standard procedure protocols and perform return demonstrations indicating an acceptable mastery of the required techniques.

## 7. Documents and Records

<b>CHEERS Study Clinical Documents and Records</b>	<b>Personnel Responsible for Developing and Storage</b>	<b>Storage Type</b>	<b>Distribution List</b>
QAPP # 3 with appendices.	Clinical Project Manager	Computer file Hard copy	- All CHEERS study personnel - MWRDGC liaison
IRB certification status for CHEERS clinical personnel	Clinical project manager	Computer file Log book	- Survey Project Manager - Clinical Project Manager
SRL training completion	SRL/ ASD-Q	Computer file Training log	- Survey Project Manager
Clinical evaluation forms	ASD- Q	Computer file Hard copy	- Field Data Coordinator - All CHEERS clinical personnel - Clinical Project Manager
UIC Microbiology Laboratory protocols	UIH Labs	Computer file Hard copy	- Clinical Project Manager
Paper-based forms (logs)	Clinical project manager	Copied and stored in a secure file folder	- Clinical Project Manager - Study Director
Instructions for use of stool collection kit at home	Clinical project manager	Computer file Hard copy kept in Room 210	- Clinical Project Manager - All CHEERS field personnel
Reminder mailing	Clinical project manager	Computer file Hard copy kept in Room 210	- Clinical Project Manager

**Table 1: Index of Documents and Records, Storage and Distribution**

A copy of the QAPP 3 will be stored in a binder with all other study-related QAPP documents in the study office: Room 210, School of Public Health West. An additional print copy will be with the Clinical Project Manager. An electronic copy will be stored on the UIC Blackboard site, accessible to all clinical personnel.

## **B. DATA GENERATION AND ACQUISITION**

### **1. Sampling Process Design**

The study design, sample size calculations, sampling locations and rationale for the design are outlined in the “Overview” document. The following sections will focus on the development of sampling methods for the follow-up, home visit clinical evaluations, and the collection/transport/analyses of biologic specimens.

#### **1.1 Clinical evaluations for skin and eye symptoms**

1.1.1 Home visits can be triggered by answers given during the follow-up telephone surveys indicating the participant has eye crusting or drainage, or has wound or skin drainage, or by the participant calling the study nurse anytime during the 21-day active study participation period and reporting symptoms of eye crusting or drainage, or wound or skin lesions or drainage. Acute respiratory symptoms will not prompt a home visit, given the limited value that such a visit would have in either identifying pathogens or objectively establishing the presence of infection.

1.1.2 The clinician will contact the participant within 12 hours of notification to determine the best time within the next 24 hours, for the home visit to occur. The clinician will confirm the participant’s home address at this time.

1.1.3 One member of the home visit team will confirm the appointment with the participant, ideally 1 hour prior to the appointment, and complete the visit at the appointed hour.

1.1.4 Wearing gloves, the clinician will complete an exam of the eyes, ears, and skin. The clinician will also obtain swabs of any discharge. Culturette tubes will be labeled and placed in a laboratory transport bag with the appropriate requisition.

1.1.4.1 Conjunctivitis: Two swabs of the palpebral conjunctiva will be obtained, one swab for bacterial culture and one swab for viral culture obtained on a Dacron swab and placed in viral transport medium.

1.1.4.2 Wound: Only wound discharge will be cultured. Scabbed-over lesions or dry areas (such as cellulitis or a skin abscess) will not be cultured, nor will study personnel attempt wound drainage.

1.1.5 The clinician will complete the Home Clinical Evaluation Form (Appendix #1) prior to leaving the participant's home.

1.1.6 The swabs obtained during the home visit will be delivered to the UIC laboratory within 12 hours, either by the clinician or by courier.

## 1.2 Clinical Evaluations for Acute Gastrointestinal Symptoms

1.2.1 Reports of acute gastrointestinal (AGI) symptoms (diarrhea, vomiting, acute abdominal cramping, unrelated to menstrual cramps), either during follow-up telephone survey or by participant-initiated phone call will trigger request for stool sample collection.

1.2.2 If AGI symptoms are reported during a routine follow-up telephone survey, the participant will be sent (via FedEx) a package containing 3 Fisherbrand Commode Specimen Collection Systems (Appendix #2), printed instructions for collection, and the courier service telephone number for the participant to call when there is a sample for delivery to the UIC laboratory. The interviewer will confirm the participant's address for delivery.

1.2.3 If a participant experiences AGI symptoms anytime during the 21-day active study participation period they are encouraged to report those symptoms to the Clinical Project Manager who will arrange for overnight FedEx delivery of the stool collection kits (as noted in 1.2.2 above). All participants are mailed a magnet with the nurse's phone number and a letter encouraging them to report any symptoms immediately (Appendix #3).

1.2.4 The Survey Research Lab call center will generate a list of participants reporting AGI symptoms to the Clinical Project Manager for follow-up the next day.

1.2.5 Stool specimens will be collected three times on alternating days over a 5 day period from those reporting AGI symptoms to increase the likelihood of detecting infection caused by *Giardia*.

### 1.3 Home Visit Protocol

#### 1.3.1 Overview

Participants who report on telephone follow-up symptoms of eye drainage or crusting, skin lesion or wound drainage will require a home visit conducted by a licensed clinician (RN or MD). Additionally, participants may call the Clinical Project Manager directly if they develop specific symptoms which would trigger a home visit anytime during the 21 days of active study participation.

Based on the symptoms reported, the staff clinician will obtain specimens for culture from the participant's eye(s) or skin discharge. The clinician will also document relevant physical findings on the paper-based Home Clinical Evaluation form (Appendix #1).

The steps to be followed before and during a home visit include:

- a. Telephone interviewer will inform the study participant that based on the answers to the survey, a home visit, by a nurse or doctor for a brief follow-up exam and to obtain eye or wound drainage samples, is required. Interviewer will confirm the best telephone number to reach the study participant and indicate that they will be getting a call from a member of the clinical staff within 12 hours.
- b. Every two hours, the interviewer will notify the staff clinician via telephone or e-mail, of any participants requiring a home visit who were identified in the preceding 2 hours.
- c. The staff clinician will consult the on-call list of project team members to identify the appropriate team member that a home visit will occur within 24 hours, although preferably within 12 hours.
- d. Each home visit team member will carry a cell phone and wear UIC CHEERS study identification. The clinician will bring the home visit bag. The

clinician will follow study protocol for examining eyes (Appendix #4): obtaining necessary samples, conducting a thorough evaluation, and completing required documentation. Samples will be labeled and specimens will be entered into the transport log.

- e. One member of the home visit team will deliver the specimen to the UIC Microbiology laboratory at 820 S. Wood Street, Room 215 or will contact the courier for specimen delivery. .
- f. The clinician will fax the Home Clinical Evaluation Form to the office of the Project Manager - Questionnaire Data or personally deliver the form to that manager.
- g. The Survey Project Manager will be responsible for entering the data into a desktop computer. Project Manager - Questionnaire Data will work with CHEERS staff to complete the data entry and upload the files to the SRL server (see transmittal procedures for all computer files in QAPP #2)

#### 1.3.2 Technique for obtaining swab for culture of wound exudate

- Wash hands and don gloves.
- Explain procedure to subject.
- Cleanse wound with sterile saline rinse.
- Using aseptic technique, twirl the end of the sterile-tipped applicator stick on one square centimeter area of the open wound for five seconds.
- Insert the swab into the gel tube.
- Label specimen and requisition form. Place in plastic specimen transport bag.
- Transport immediately to the UIC laboratory for processing.

#### 1.3.3 Technique for obtaining swab culture of eye drainage.

- Wash hands and don gloves.
- Explain procedure to subject.
- Using aseptic technique, pull down the lower eyelid. Roll the swab along the inside of the lower eyelid. Do not swab over the globe of the eye.
- Replace the swab in the gel tube.

- Label specimen and requisition form. Place in plastic specimen transport bag.
- Transport immediately to the UIC laboratory for processing.

#### 1.3.4 Protocol for arranging for courier pick up:

When the call center is notified of a sample ready for delivery, the call center will either confirm that the participant has the courier contact information or the call center will call the courier with name, address, and phone number of participant. Specimen will be picked up and delivered to the UIC microbiology lab within 3 hours of notification.

#### 1.3.5 Subject notification of positive sample results:

If stool or other specimens collected are culture positive, participants will be notified of the results via telephone and US mail, along with advice to share those results with their physician (Appendices #5, #6). CDC fact sheets pertaining to the particular microbe identified will be included with the notification letter (Appendix #7). If the participant does not have a physician, he/she will be given a directory with phone numbers of low cost clinics in the Chicago area (Appendix #8).

## **2. Sampling Methods**

There is no randomization or statistical approach for obtaining health information from subsets of study participants. Clinical questions are asked of all study participants in the field and telephone interviews. Clinical specimen collection is triggered by specific responses to those questions among all study participants.

## **3. Sample Handling and Custody**

- 3.1 Before concluding the home visit, the clinician will label the wound and eye drainage specimens with subject's Case ID number, date and clinician's initials. Afterwards, the clinician will place the samples in a plastic specimen transport bag with the UIC requisition form.
- 3.2 The clinician will then complete the specimen chain of custody log (Appendix #9) and terminate the home visit.

- 3.3 Immediately following the home visit, the clinician will deliver the specimens to the UIC Microbiology lab, Room 215. The person receiving the specimens in the lab will sign and date the specimen log. The clinician may elect to use the courier service to deliver the specimen to the UIC lab. In which case, the courier service would be called immediately upon termination of the home visit and have the specimen delivered within 3 hours of notification.
- 3.4 Lab access – With building “swipe” access, specimens can be delivered between 7:00 AM and 9:00 PM from Monday through Friday, 7:00 AM and 6:00 PM on Saturday, and 7:00 AM and 3:00 PM Sundays.
- 3.5 If the subject reports acute gastrointestinal illness and has already obtained and labeled the stool sample, the courier will pick up the specimen. If pick-up occurs after normal business hours, lab specimens can be delivered to the UIH Microbiology laboratory’s loading dock via the “FED EX” bell.

#### **4. Analytical Methods**

##### **4.1 Stool samples**

Upon receipt of the sample in the UIC microbiology laboratory, an aliquot of the sample will be removed from the stool sample container, placed in transport medium, labeled, and then transferred to the IDPH microbiology laboratory by courier for Norovirus and Shiga toxin analysis. The sample will be received and tracked in the IDPH laboratory by established protocol, analyzing the samples by real-time reverse transcriptase polymerase chain reaction.



<b>Pathogen/ Specimen source</b>	<b>Lab and Analytical Method</b>	<b>Appendix #</b>
Stool culture	UIC hospital microbiology lab Stool culture	10
Stool viral culture	UIC hospital microbiology lab Virus isolation specimens Virus identification Virus isolation identification	11-a 11-b 11-c
Cryptosporidium Giardia	UIC hospital microbiology lab Enteric protozoa by direct immunofluorescence	12
Rotavirus	UIC hospital microbiology lab Rotavirus by enzyme immunoassay	13
Eye discharge	UIC hospital microbiology lab Eye cultures	14
Wound discharge	UIC hospital microbiology lab Wound Culture	15
Enterovirus	IDPH microbiology lab: Shigatoxin protocol	16
Norovirus	IDPH microbiology lab: Norovirus by real-time reverse transcriptase polymerase chain reaction	17

**Table 2. Index of Analytic Methods for Clinical Specimens**

At the UIC hospital microbiology laboratory, stool samples will be analyzed for enteric pathogens and protozoa, including *Cryptosporidium* and *Giardia*, following the laboratory's standard operating procedures by direct immunofluorescence. Stool specimens will also be analyzed for rotavirus by enzyme immunoassay. Additionally, specimens will be analyzed for the presence of enteroviruses by cell culture.

#### 4.2 Eye swabs

Eye swabs will be analyzed by the UIC Hospital Microbiology Laboratory by culture following the laboratory's standard protocol (Appendix #14).

#### 4.3 Wound swabs

Wound swabs will be analyzed by the UIC Hospital Microbiology Laboratory by culture following the laboratory's standard protocol (Appendix #15).

### **5. Quality Control**

#### 5.1 Quality Control Measures for Clinical Data Analysis

- a. The UIC laboratory and IDPH laboratory are fully certified and have their own internal QA/QC protocols (Appendices 18-21).
- b. The laboratory's QA manager will provide the Clinical Project Manager their laboratory's internal QC data on a quarterly basis for review.

#### 5.2 Quality Control for Clinical Data Collection

- 5.2.1 The Clinical Project Manager will be responsible for ensuring the clinical staff conforms to the study protocols.
- 5.2.2 Quality of the health assessment and sampling procedures will be assured by consistent training of clinical staff and periodic review of home visit evaluation forms and unusual occurrence logs.
- 5.2.3 Accuracy of the data entry will be ensured by staff training, before the start of each year's recreation season, and also through random quality assurance checks throughout the season.
- 5.2.4 The unsatisfactory specimen log will indicate the frequency of incomplete, poorly prepared, or incompletely identified specimens and the final disposition of these samples (identified, unable to analyze due to lack of proper identification, etc.).

5.2.5 The Clinical Project Manager will review the log, analyze for problem areas, and report unsatisfactory outcomes. Clinical staff will be re-trained as deemed necessary to maintain quality data outcomes.

## **6. Instrument/Equipment Testing, Inspection, and Maintenance**

The UIC Hospital and IDPH laboratories are both certified laboratories with their own QA/QC protocols. Instrument testing, inspection, and maintenance will be conducted per their respective protocols. There are no instruments specific to handling or analyzing CHEERS clinical specimens.

## **7. Instrument/Equipment Calibration and Frequency**

The UIC Hospital and IDPH laboratories are both certified laboratories with their own QA/QC protocols. Instrument calibration and frequency will be conducted per their respective protocols. There are no instruments specific to handling or analyzing CHEERS clinical specimens.

## **8. Inspection/Acceptance of Supplies and Consumables**

The RN on call is responsible for inspection and maintenance of the home visit bag. Contents will be listed on a checklist, stored in the bag. Missing items can be replenished from the CHEERS stockroom.

### Contents of the “Home Visit Bag”

1. Culturette tubes
2. Latex exam gloves
3. Biohazard (“red”) bags for disposal
4. Otoscope
5. Disposable measuring tape
6. Clipboard and pen
7. Notebook
8. Home visit data forms
9. Sample ID labels

## **9. Non-Direct Measurements**

Does not apply to this protocol.

## **10. Data Management**

Home evaluation data will be uploaded by the Survey Project Manager and sent to the SRL for analysis. All sample data will remain stripped of personal identifiers. Logs of laboratory data will be kept by the Clinical Project Manager in a password-protected computer file. All paper copies will be stored in a locked cabinet. IDPH provides paper copies of all lab results directly to the Principal Investigator. UIH provides paper copies of all lab results to the Clinical Project Manager. UIH lab notifies the Clinical Project Manager by telephone immediately when an abnormal result is obtained.

## **11. Archiving Clinical Specimens**

When pathogens are identified in stool samples, both the UIH and IDPH laboratories will freeze an aliquot of the sample in the sub-zero freezer for possible future investigation. Additionally, IDPH lab will freeze a sample of all raw stool received (Appendices # 22 and 23).

## **12. Disease Reporting**

11.1 Notifiable Disease Reporting will comply with Illinois requirements.

In the context of this research, it is possible the cases of Giardiasis, Cryptosporidiosis, Salmonellosis, Shigellosis will be identified. Less likely cases of Yersiniosis, Shigatoxin-positive enteritis and Cyclosporiasis may be reported. The Clinical Project manager will contact the Illinois Department of Public Health and provide any information required by law.

## **C. ASSESSMENT AND OVERSIGHT**

### **1. Assessments and Response Actions**

Reviews of the data quality will be performed regularly, as outlined in the system wide quality management plan (QMP). This project includes several streams of data quality monitoring and we will use a graded approach to review them.

At weekly reviews, we will note, revise and develop ways to prevent unusual occurrences that have been reported in the preceding week, which could include:

- a. The rejection of samples by the microbiology labs for various reasons.
- b. Improper or incomplete data entry during field clinical assessment
- c. Incomplete data entry during home visit.
- d. Failure to complete home visit within the timeframe prescribed per protocol.

At monthly quality reviews, summary statistics of laboratory results and UIH internal laboratory QC data will be reviewed.

At annual quality reviews, all quality data will be reviewed. Emphasis will be placed on system-wide quality issues with the goal of developing quality improvement strategies for the next recreation season.

### **2. Reports to Management**

The Clinical Project Manager will receive hard copy reports daily from the UIH and IDPH microbiology laboratories. All data will be entered a CHEERS clinical microbiology data file, devoid of all personal identifiers. The study director will be notified of all positive cultures. A summary data report will be generated monthly by the Clinical Project Manager and shared with the Study Director and Quality Manager.

The Clinical Project Manager will also maintain an Unusual Occurrence log to document any unexpected occurrence with personnel, subjects, data collection/handling, or data reporting. (Appendix #24)

## **D. DATA VALIDATION AND USABILITY**

### **1. Data Review, Verification, and Validation**

Data review, verification, and validation methods have been employed during the development, programming and implementation of the clinical data gathering process. These include questionnaire review and validation processes, including internal/external reviews, IRB clearance, and pilot evaluations of survey questions. Specifically:

- The computer assisted surveys have been developed with pre-determined acceptable response options. This prevents the entry of unacceptable or out-of-range responses.
- Data will be deemed unusable if a laboratory reports a specimen as unusable.

### **2. Verification and Validation Methods**

Novel methods are not employed for data collection or analysis. Validation of methods will not be necessary.

### **3. Reconciliation with User Requirements**

The clinical data collected were selected specifically for this research. Clinical microbiology data reported by laboratories as having been obtained from acceptable specimens will be used without any reconciliation.

# **CHEERS QAPP 3**

## **Appendix 1: Home clinical evaluation form**

**UNIVERSITY OF ILLINOIS, CHICAGO  
CHEERS HOME VISIT CLINICAL EVALUATION**

Clinician Name: \_\_\_\_\_

1. You said you had a red, or sore, or draining area on your skin when we last spoke to you on (fill date of late telephone interview). I will examine your skin now. (Fill location of skin wound/cut/bruise/bug bite from telephone survey Q 13a).

Observation:

- a. Warmth around the wound? Y N RF DK
- b. Is there any tenderness/pain? Y N RF DK
- c. Any surrounding erythema (measure diameter in mm)? Y \_\_\_mm N RF DK
- d. Any discharge from the wound? Y N RF DK
- e. Are you currently being treated with any antibiotics or prescription medications for this? Y N RF DK
- f. IF Yes, Is this topical or oral?

Topical/ Oral RF DK

2. I will examine your skin for any other similar cuts, bruises, bug bites, or wounds.

Note: Nurse/Physician records observations. Look for infected cuts, bruises, insect bites. Check all that apply.

Right side		Left side	
Head/ Face	Y N RF DK	Head/ Face	Y N RF DK
Neck	Y N RF DK	Neck	Y N RF DK
Upper Arm	Y N RF DK	Upper Arm	Y N RF DK
Fore Arm	Y N RF DK	Fore Arm	Y N RF DK
Hand	Y N RF DK	Hand	Y N RF DK
Thigh	Y N RF DK	Thigh	Y N RF DK
Lower leg	Y N RF DK	Lower leg	Y N RF DK
Ankle/ Foot	Y N RF DK	Ankle/ Foot	Y N RF DK

Note: For each "Yes"- then observe wound-

You have an open cut/wound/insect bite/ scrape. I am going to briefly examine this now.

Observation:

- a. Warmth around the wound? Y N RF DK
- b. Is there any tenderness/pain? Y N RF DK
- c. Any surrounding erythema (measure diameter in mm)? Y \_\_\_mm N RF DK



- d. Any discharge from the wound? Y N RF DK
- e. Are you currently being treated with any antibiotics or prescription medications for this? Y N RF DK
- f. IF Yes, Is this topical or oral?

Topical/ Oral RF DK

- 3. You said you had eye irritation or draining and crusting in your eyes when we last spoke to you on (fill date of late telephone interview). I am going to examine your eyes now.

		0-None	1-Mild	2-Severe	7 - RF	8 - DK
a. Discharge	Left eye Right eye					
b. Injection of conjunctiva	Left eye Right eye					
c. Chemosis	Left eye Right eye					

3d. Have you been diagnosed with an eye infection since we last spoke to you on (fill Date of survey or last telephone interview)? Y N RF DK

3e. If YES, was it the ....

- Left eye,
- Right eye
- Both eyes
- RF DK

3f. Are you currently being treated with any antibiotics or prescription eye drops? Y N RF DK

- 4. You said you ear ache or an ear infection when we last spoke to you on (fill date of late telephone interview). I am going to examine your ears now.

		0- None	1- Mild	2- Severe	7 – RF	8 - DK
a. Discharge	Left ear Right ear					
b. Canal edema	Left ear Right ear					

c. Canal erythema	Left ear Right ear					
d. Pain with traction	Left ear Right ear					

4e. Have you been diagnosed with an ear infection since we last spoke to you on (fill Date of survey or last telephone interview)? Y N RF DK

4f. If yes, was it the ...

- Left ear,
- Right ear
- Both ears
- RF DK

4g. Are you currently being treated with any antibiotics or prescription ear drops? Y N RF DK

4h. If Yes, is this oral or drops? Oral/ Drops RF DK

5. Specimen collection Y N RF

5a. If YES-  
 Stool sample Day 1 / 2 / 3  
 Skin discharge  
 Eye discharge

# **CHEERS QAPP 3**

## **Appendix 2: Specimen Collection System**

**Fisherbrand\* Commode Specimen Collection System**  
Fisher Health Catalog # 02-544-208



- Stool need not be handled
- Sturdy frame enables container to fit securely under any toilet seat
- Lid is snapped on, and support frame is easily removed by snapping it down for transportation to lab
- Doubles for female urine output
- Easy-to-read graduations on container
- Directions are printed on container lid in both English and Spanish

# **CHEERS QAPP 3**

## **Appendix 3: Letter to study participants**

Thank you for participating in the  
CHEERS study.



**Remember, we want to know about your health over the next 21 days of the study period.**

**CHEERS**  
WATER CHICAGO SPORTS

If you have any: **abdominal pain, vomiting, or diarrhea** -

1. Please collect a stool sample using the stool kit provided.
2. Call the courier service at **1.888.333.9112** to schedule a pick-up of your specimen (just tell them that you're in the UIC CHEERS project).
3. Be sure to have the gold lab requisition form with your ID number in the bag with the collected specimen.
4. Call the **CHEERS call center at 1.800.688.0582** to report your symptoms.

If you have any: **eye crusting or drainage, or any skin wounds with drainage** -

- ❖ Please call the **CHEERS call center at 1.800.688.0582** to report your symptoms.

If you need a stool kit or a gold requisition form -

- ❖ Please call the **CHEERS call center at 1.800.688.0582**.

If you have any other questions or concerns regarding the stool collection procedure or the home visit-

- ❖ Please call the **CHEERS nurse at 312-996-3395**.

**Note: You will receive an additional \$ 75 for providing any of the above specimens.**

Thanks.

Jackee Wuellner, RN  
Phone 312-996-3395

# **CHEERS QAPP 3**

## **Appendix 4: Conjunctivitis Rating Scale**

**TABLE 1.** Rating scale and definitions for cardinal signs

Cardinal Sign	Rating			
	(0) Absent/Normal	(1) Mild	(2) Moderate	(3) Severe
Conjunctival discharge	No discharge noted in lower cul-de-sac	Small amount of mucopurulent or purulent discharge noted in lower cul-de-sac; no true matting of eyelids on arising	Moderate amount of mucopurulent or purulent discharge noted in the lower cul-de-sac; obvious matting together of eyelids on arising	Profuse amount of mucopurulent or purulent discharge noted in lower cul-de-sac and marginal tear strip, eyelids tightly matted together upon arising, requiring warm soaks to pry lids apart
Bulbar conjunctival injection	Normal vascular pattern of conjunctiva	Diffuse vascular injection of a mild degree, usually without subconjunctival hemorrhages	Diffuse hyperemia obvious from a distance may have scattered petechiae-associated subconjunctival hemorrhages	"Beet" red eye may have subconjunctival hemorrhages present in significant numbers and sizes
Palpebral conjunctival injection	Normal upper tarsus papillary response	Diffuse follicular pattern (small follicles), or discrete fine papillary reaction, with mild hyperemia; upper tarsus papillary response not normal, but does not obscure underlying details	Diffuse follicular reaction (large follicles) or diffuse confluent papillary response, pronounced hyperemia, usually without hemorrhage(s) upper tarsus papillary response blurs underlying details	Marked inflammatory changes in subconjunctival tissue with evidence of epithelial necrosis; upper tarsus papillary response eliminates underlying details

Conjunctivitis Rating Scale of Lichtenstein, et. J AOPPS, 2003



# **CHEERS QAPP 3**

## **Appendix 5: Positive Culture Letter Stool**



Dear First, Last Name,

On (Month, Date,) 2008 we obtained a stool sample from you. Testing showed that you have an infection known as (pathogen). Please contact your doctor and let him/her know that you have this infection. Your doctor can contact the CHEERS study clinical director for further details. Jackee Wuellner, RN can be reached at (312) 996-3395.

Enclosed is an information sheet for you about this condition. Be sure to follow-up soon with your doctor, and if your condition is worsening, be sure to seek treatment right away.

Thank you for your participation in CHEERS.

Sam Dorevitch, MD, MPH  
Study Director  
UIC School of Public Health

# **CHEERS QAPP 3**

## **Appendix 6: Positive Culture Letter Eye/Wound**



Date

Dear \_\_\_\_\_,

On \_\_\_\_\_ we obtained a (wound/eye) swab from you. Testing showed that you have an infection known as \_\_\_\_\_. Please contact your doctor and let him/her know that you have this infection. Your doctor can contact the CHEERS study clinical director for further details by calling the Clinical Director of the CHEERS study, Jackee Wuellner, at (312) 996-3395.

Enclosed is an information sheet for you about this condition. Be sure to follow-up soon with your doctor, and if your condition is worsening, be sure to seek treatment right away.

Thank you for your participation in CHEERS.

Sam Dorevitch, MD, MPH  
Study Director  
UIC School of Public Health

# **CHEERS QAPP 3**

## **Appendix 7: Fact Sheets**



## Division of Parasitic Diseases

1 of 4

### ***Cryptosporidium* Infection**

#### **Cryptosporidiosis (KRIP-toe-spo-rid-ee-OH-sis)**

##### **What is cryptosporidiosis?**

Cryptosporidiosis is a diarrheal disease caused by microscopic parasites of the genus *Cryptosporidium*. Once an animal or person is infected, the parasite lives in the intestine and passes in the stool. The parasite is protected by an outer shell that allows

it to survive outside the body for long periods of time and makes it very resistant to chlorine-based disinfectants. Both the disease and the parasite are commonly known as "crypto."

During the past two decades, crypto has become recognized as one of the most common causes of waterborne disease within humans in the United States. The parasite may be found in drinking water and recreational water in every region of the United States and throughout the world.

##### **How is cryptosporidiosis spread?**

*Cryptosporidium* lives in the intestine of infected humans or animals. Millions of crypto

germs can be released in a bowel movement from an infected human or animal. Consequently, *Cryptosporidium* is found in soil, food, water, or surfaces that have been

contaminated with infected human or animal feces. If a person swallows the parasite they become infected. You **cannot** become infected through contact with blood. The parasite can be spread by

- Accidentally putting something into your mouth or swallowing something that has come into contact with feces of a person or animal infected with *Cryptosporidium*.
- Swallowing recreational water contaminated with *Cryptosporidium* (Recreational water includes water in swimming pools, hot tubs, jacuzzis, fountains, lakes, rivers, springs, ponds, or streams that can be contaminated with sewage or feces from humans or animals.) **Note:** *Cryptosporidium* can survive for days in swimming pools with adequate chlorine levels.
- Eating uncooked food contaminated with *Cryptosporidium*. Thoroughly wash with clean, safe water all vegetables and fruits you plan to eat raw. See below for information on making water safe.
- Accidentally swallowing *Cryptosporidium* picked up from surfaces (such as bathroom fixtures, changing tables, diaper pails, or toys) contaminated with feces from an infected person.

##### **What are the symptoms of cryptosporidiosis?**

The most common symptom of cryptosporidiosis is watery diarrhea. Other symptoms include:

- Dehydration
- Weight loss
- Stomach cramps or pain
- Fever
- Nausea
- Vomiting

Some people with crypto will have no symptoms at all. While the small intestine is the site most commonly affected, *Cryptosporidium* infections could possibly affect other areas of the digestive or the respiratory tract.

### **How long after infection do symptoms appear?**

Symptoms of cryptosporidiosis generally begin 2 to 10 days (average 7 days) after becoming infected with the parasite.

### **How long will symptoms last?**

In persons with healthy immune systems, symptoms usually last about 1 to 2 weeks. The symptoms may go in cycles in which you may seem to get better for a few days, then feel worse again before the illness ends.

### **If I have been diagnosed with *Cryptosporidium*, should I worry about spreading the infection to others?**

Yes, *Cryptosporidium* can be very contagious. Follow these guidelines to avoid spreading the disease to others:

1. Wash your hands with soap and water after using the toilet, changing diapers, and before eating or preparing food.
2. Do not swim in recreational water (pools, hot tubs, lakes or rivers, the ocean, etc.) if you have cryptosporidiosis and for at least 2 weeks after diarrhea stops. You can pass *Cryptosporidium* in your stool and contaminate water for several weeks after your symptoms have ended. This has resulted in outbreaks of cryptosporidiosis among recreational water users. **Note:** *Cryptosporidium* can be spread in a chlorinated pool because it is resistant to chlorine and, therefore, can live for days in chlorine-treated swimming pools.
3. Avoid fecal exposure during sexual activity.

### **Who is most at risk for cryptosporidiosis?**

People who are most likely to become infected with *Cryptosporidium* include:

- Children who attend day care centers, including diaper-aged children
- Child care workers
- Parents of infected children
- International travelers
- Backpackers, hikers, and campers who drink unfiltered, untreated water
- Swimmers who swallow water while swimming in swimming pools, lakes, rivers, ponds, and streams
- People who drink from shallow, unprotected wells
- People who swallow water from contaminated sources.

Contaminated water includes water that has not been boiled or filtered. Several community-wide outbreaks of cryptosporidiosis have been linked to drinking municipal

water or recreational water contaminated with *Cryptosporidium*.

### **Who is most at risk for getting seriously ill with cryptosporidiosis?**

Although Crypto can infect all people, some groups are more likely to develop more serious illness.

- Young children and pregnant women may be more susceptible to the dehydration resulting from diarrhea and should drink plenty of fluids while ill.
- If you have a severely weakened immune system, you are at risk for more serious disease. Your symptoms may be more severe and could lead to serious or lifethreatening illness. Examples of persons with weakened immune systems include those with HIV/AIDS; cancer and transplant patients who are taking certain immunosuppressive drugs; and those with inherited diseases that affect the immune system. If you have a severely weakened immune system, talk to your health care provider for additional guidance.

You can also call the CDC AIDS HOTLINE toll-free at 1-800- 342-2437. Ask for more information on cryptosporidiosis, or go to the CDC fact sheet *Preventing Cryptosporidiosis: A Guide for People with Compromised Immune Systems* available by visiting

### **What should I do if I think I may have cryptosporidiosis?**

If you suspect that you have cryptosporidiosis, see your health care provider.

### **How is a cryptosporidiosis diagnosed?**

Your health care provider will ask you to submit stool samples to see if you are infected.

Because testing for Crypto can be difficult, you may be asked to submit several stool specimens over several days. Tests for Crypto are not routinely done in most laboratories; therefore, your health care provider should specifically request testing for the parasite.

### **What is the treatment for cryptosporidiosis?**

A new drug, nitazoxanide, has been approved for treatment of diarrhea caused by *Cryptosporidium* in people with healthy immune systems. Consult with your health care provider for more information. Most people who have a healthy immune system will recover without treatment. The symptoms of diarrhea can be treated. If you have diarrhea, drink plenty of fluids to prevent dehydration. Rapid loss of fluids from diarrhea may be especially life threatening to babies; therefore, parents should talk to their health care provider about fluid replacement therapy options for infants. Anti-diarrheal medicine may help slow down diarrhea, but talk to your health care provider before taking it.

People who are in poor health or who have a weakened immune system are at higher risk for more severe and more prolonged illness. The effectiveness of nitazoxanide in immunosuppressed individuals is unclear. For persons with AIDS, anti-retroviral therapy that improves immune status will also decrease or eliminate symptoms of Crypto. However, even if symptoms disappear, cryptosporidiosis is usually not curable and the symptoms may return if the immune status worsens. See your health care provider to discuss anti-retroviral therapy used to improve your immune status.

### **How can I prevent cryptosporidiosis?**

#### **Practice good hygiene.**

1. Wash hands thoroughly with soap and water. a. Wash hands after using the toilet and before handling or eating food (especially for persons with diarrhea). b. Wash hands after every diaper change, especially if you work with diaper-aged children, even if you are wearing gloves.



2. Protect others by not swimming if you are experiencing diarrhea (essential for children in diapers).

**Avoid water that might be contaminated.**

1. Do not swallow recreational water.
2. Do not drink untreated water from shallow wells, lakes, rivers, springs, ponds, and streams.
3. Do not drink untreated water during community-wide outbreaks of disease caused by contaminated drinking water.
4. Do not use untreated ice or drinking water when traveling in countries where the water supply might be unsafe. In the United States, nationally distributed brands of bottled or canned carbonated soft drinks are safe to drink. Commercially packaged non-carbonated soft drinks and fruit juices that do not require refrigeration until after they are opened (those that are stored unrefrigerated on grocery shelves) also are safe. If you are unable to avoid using or drinking water that might be contaminated, then you can make the water safe to drink by doing one of the following:

- Heat the water to a rolling boil for at least 1 minute. OR
- Use a filter that has an absolute pore size of at least 1 micron or one that has been NSF rated for "cyst removal."

Do not rely on chemicals to disinfect water and kill *Cryptosporidium*. Because it has a thick outer shell, this particular parasite is highly resistant to disinfectants such as chlorine and iodine.

**Avoid food that might be contaminated.**

1. Wash and/or peel all raw vegetables and fruits before eating.
2. Use safe, uncontaminated water to wash all food that is to be eaten raw.
3. Avoid eating uncooked foods when traveling in countries with minimal water treatment and sanitation systems.

**Take extra care when traveling.**

If you travel to developing nations, you may be at a greater risk for *Cryptosporidium* infection because of poorer water treatment and food sanitation. Warnings about food, drinks, and swimming are even more important when visiting developing countries. Avoid foods and drinks, in particular raw fruits and vegetables, tap water, or ice made from tap water, unpasteurized milk or dairy products, and items purchased from street vendors. These items may be contaminated with *Cryptosporidium*. Steaming-hot foods, fruits you peel yourself, bottled and canned processed drinks, and hot coffee or hot tea are probably safe. Talk with your health care provider about other guidelines for travel abroad.

**Avoid fecal exposure during sexual activity.**

*This fact sheet is for information only and is not meant to be used for self-diagnosis or as a substitute for consultation with a health care provider.*

For information on choosing safe bottled water, see the CDC fact sheet entitled "Preventing Cryptosporidiosis: A Guide to Water Filters and Bottled Water," available by visiting <http://www.cdc.gov/ncidod/dpd/parasites/cryptosporidiosis/>

For information on choosing a water filter, see the CDC fact sheet entitled "Preventing Cryptosporidiosis: A Guide to Water Filters and Bottled Water," available by visiting <http://www.cdc.gov/ncidod/dpd/parasites/cryptosporidiosis/>



Department of Health and Human Services

Centers for Disease Control and Prevention

## **Salmonella**

### **What is salmonellosis?**

Salmonellosis is an infection with a bacteria called Salmonella. Most persons infected with Salmonella develop diarrhea, fever, and abdominal cramps 12 to 72 hours after infection. The illness usually lasts 4 to 7 days, and most persons recover without treatment. However, in some persons the diarrhea may be so severe that the patient needs to be hospitalized. In these patients, the Salmonella infection may spread from the intestines to the blood stream, and then to other body sites and can cause death unless the person is treated promptly with antibiotics. The elderly, infants, and those with impaired immune systems are more likely to have a severe illness.

### **What sort of germ is Salmonella?**

The Salmonella germ is actually a group of bacteria that can cause diarrheal illness in humans. They are microscopic living creatures that pass from the feces of people or animals, to other people or other animals. There are many different kinds of Salmonella bacteria. Salmonella serotype Typhimurium and Salmonella serotype Enteritidis are the most common in the United States. Salmonella has been known to cause illness for over 100 years. They were discovered by a American scientist named Salmon, for whom they are named.

### **How can Salmonella infections be diagnosed?**

Many different kinds of illnesses can cause diarrhea, fever, or abdominal cramps. Determining that Salmonella is the cause of the illness depends on laboratory tests that identify Salmonella in the stools of an infected person. These tests are sometimes not performed unless the laboratory is instructed specifically to look for the organism. Once Salmonella has been identified, further testing can determine its specific type, and which antibiotics could be used to treat it.

### **How can Salmonella infections be treated?**

Salmonella infections usually resolve in 5-7 days and often do not require treatment unless the patient becomes severely dehydrated or the infection spreads from the intestines. Persons with severe diarrhea may require rehydration, often with intravenous fluids. Antibiotics are not usually necessary unless the infection spreads from the intestines, then it can be treated with ampicillin, gentamicin, trimethoprim/sulfamethoxazole, or ciprofloxacin. Unfortunately, some Salmonella

## **Salmonella p. 2**

bacteria have become resistant to antibiotics, largely as a result of the use of antibiotics to promote the growth of feed animals.

### **Are there long term consequences to a Salmonella infection?**

Persons with diarrhea usually recover completely, although it may be several months before their bowel habits are entirely normal. A small number of persons who are infected with Salmonella, will go on to develop pains in their joints, irritation of the eyes, and painful urination. This is called Reiter's syndrome. It can last for months or years, and can lead to chronic arthritis which is difficult to treat. Antibiotic treatment does not make a difference in whether or not the person later develops arthritis.

### **How do people catch Salmonella?**

Salmonella live in the intestinal tracts of humans and other animals, including birds. Salmonella are usually transmitted to humans by eating foods contaminated with animal feces. Contaminated foods usually look and smell normal. Contaminated foods are often of animal origin, such as beef, poultry, milk, or eggs, but all foods, including vegetables may become contaminated. Many raw foods of animal origin are frequently contaminated, but fortunately, thorough cooking kills Salmonella. Food may also become contaminated by the unwashed hands of an infected food handler, who forgot to wash his or her hands with soap after using the bathroom.

Salmonella may also be found in the feces of some pets, especially those with diarrhea, and people can become infected if they do not wash their hands after contact with these feces. Reptiles are particularly likely to harbor Salmonella and people should always wash their hands immediately after handling a reptile, even if the reptile is healthy. Adults should also be careful that children wash their hands after handling a reptile.

### **What can I do to prevent salmonellosis?**

- Cook poultry, ground beef, and eggs thoroughly before eating. Do not eat or drink foods containing raw eggs, or raw unpasteurized milk.
- If you are served undercooked meat, poultry or eggs in a restaurant, don't hesitate to send it back to the kitchen for further cooking.
- Wash hands, kitchen work surfaces, and utensils with soap and water immediately after they have been in contact with raw meat or poultry.
- Be particularly careful with foods prepared for infants, the elderly, and the immunocompromised.
- Wash hands with soap after handling reptiles or birds, or after contact with pet feces.
- Avoid direct or even indirect contact between reptiles (turtles, iguanas, other lizards, snakes) and infants or immunocompromised persons.

### **Salmonella p. 3**

- Don't work with raw poultry or meat, and an infant (e.g., feed, change diaper) at the same time.
- Mother's milk is the safest food for young infants. Breast-feeding prevents salmonellosis and many other health problems.

Date: November 4, 2006

Content source: Coordinating Center for Infectious Diseases / Division of Bacterial and Mycotic Diseases

Adapted from: [http://www.cdc.gov/ncidod/dbmd/diseaseinfo/salmonellosis\\_g.htm](http://www.cdc.gov/ncidod/dbmd/diseaseinfo/salmonellosis_g.htm)

## *CDC Answers Your Questions About Noroviruses:*

### **What are noroviruses?**

Noroviruses are a group of viruses that cause the “stomach flu,” or gastroenteritis (GAS-tro-enter- I-tis), in people. The term norovirus was recently approved as the official name for this group of viruses. Several other names have been used for noroviruses, including:

- Norwalk-like viruses (NLVs)
- caliciviruses (because they belong to the virus family *Caliciviridae*)
- small round structured viruses.

Viruses are very different from bacteria and parasites, some of which can cause illnesses similar to norovirus infection. Viruses are much smaller, are not affected by treatment with antibiotics, and cannot grow outside of a person’s body.

### **What are the symptoms of illness caused by noroviruses?**

The symptoms of norovirus illness usually include nausea, vomiting, diarrhea, and some stomach cramping. Sometimes people additionally have a low-grade fever, chills, headache, muscle aches, and a general sense of tiredness. The illness often begins suddenly, and the infected person may feel very sick. The illness is usually brief, with symptoms lasting only about 1 or 2 days. In general, children experience more vomiting than adults. Most people with norovirus illness have both of these symptoms.

### **What is the name of the illness caused by noroviruses?**

Illness caused by norovirus infection has several names, including:

- stomach flu – this “stomach flu” is *not* related to the flu (or influenza), which is a respiratory illness caused by influenza virus.
- viral gastroenteritis – the most common name for illness caused by norovirus.

Gastroenteritis refers to an inflammation of the stomach and intestines.

- acute gastroenteritis
- non-bacterial gastroenteritis
- food poisoning (although there are other causes of food poisoning)
- calicivirus infection

### **How serious is norovirus disease?**

Norovirus disease is usually not serious, although people may feel very sick and vomit many times a day. Most people get better within 1 or 2 days, and they have no long-term health effects related to their illness. However, sometimes people are unable to drink enough liquids to replace the liquids they lost because of vomiting and diarrhea. These persons can become dehydrated and may need special medical attention. This problem with dehydration is usually only seen among the very young, the elderly, and persons with weakened immune systems. There is no evidence to suggest that an infected person can become a long-term carrier of norovirus.

### **How do people become infected with noroviruses?**

Noroviruses are found in the stool or vomit of infected people. People can become infected with the virus in several ways, including:

## *CDC Answers Your Questions About Norovirus*

- eating food ([see food handler fact sheet](#)) or drinking liquids that are contaminated with norovirus;
- touching surfaces or objects contaminated with norovirus, and then placing their hand in their mouth;
- having direct contact with another person who is infected and showing symptoms (for example, when caring for someone with illness, or sharing foods or eating utensils with someone who is ill).

Persons working in day-care centers or nursing homes should pay special attention to children or residents who have norovirus illness. This virus is very contagious and can spread rapidly throughout such environments.

### **When do symptoms appear?**

Symptoms of norovirus illness usually begin about 24 to 48 hours after ingestion of the virus, but they can appear as early as 12 hours after exposure.

### **Are noroviruses contagious?**

Noroviruses are very contagious and can spread easily from person to person. Both stool and vomit are infectious. Particular care should be taken with young children in diapers who may have diarrhea.

### **How long are people contagious?**

People infected with norovirus are contagious from the moment they begin feeling ill to at least 3 days after recovery. Some people may be contagious for as long as 2 weeks after recovery. Therefore, it is particularly important for people to use good handwashing and other hygienic practices after they have recently recovered from norovirus illness.

### **Who gets norovirus infection?**

Anyone can become infected with these viruses. There are many different strains of norovirus, which makes it difficult for a person's body to develop long-lasting immunity. Therefore, norovirus illness can recur throughout a person's lifetime. In addition, because of differences in genetic factors, some people are more likely to become infected and develop more severe illness than others.

### **What treatment is available for people with norovirus infection?**

Currently, there is no antiviral medication that works against norovirus and there is no vaccine to prevent infection. Norovirus infection cannot be treated with antibiotics. This is because antibiotics work to fight bacteria and not viruses. Norovirus illness is usually brief in healthy individuals. When people are ill with vomiting and diarrhea, they should drink plenty of fluids to prevent dehydration. Dehydration among young children, the elderly, the sick, can be common, and it is the most serious health effect that can result from norovirus infection. By drinking oral rehydration fluids (ORF), juice, or water, people can reduce their chance of becoming dehydrated. Sports drinks do not replace the nutrients and minerals lost during this illness.

### **Can norovirus infections be prevented?**

Yes. You can decrease your chance of coming in contact with noroviruses by following these *CDC Answers Your Questions About Norovirus* preventive steps:

- Frequently wash your hands, especially after toilet visits and changing diapers and before eating or preparing food.
- Carefully wash fruits and vegetables, and steam oysters before eating them.
- Thoroughly clean and disinfect contaminated surfaces immediately after an episode of illness by using a bleach-based household cleaner.
- Immediately remove and wash clothing or linens that may be contaminated with virus after an episode of illness (use hot water and soap).
- Flush or discard any vomitus and/or stool in the toilet and make sure that the surrounding area is kept clean.

Persons who are infected with norovirus should not prepare food while they have symptoms and for 3 days after they recover from their illness ([see food handler information sheet](#)). Food that may have been contaminated by an ill person should be disposed of properly.

## Diarrhea

### Alternative names

Stools - watery; Frequent bowel movements; Loose bowel movements

### Definition

Diarrhea is loose, watery, and frequent stool. Diarrhea is considered chronic (long-term) when you have had loose or frequent stools for more than 4 weeks.

### Considerations

Diarrhea in adults is usually mild and goes away quickly without complications. In infants and children (especially under age 3), diarrhea can cause dehydration fairly quickly.

### Common Causes

The most common cause of diarrhea is viral gastroenteritis, a mild viral infection that goes away on its own within a few days. This condition is often called the stomach flu. Viral gastroenteritis often occurs in mini-epidemics in schools, neighborhoods, or families.

Food poisoning and traveler's diarrhea are two other common causes of diarrhea. They occur as a result of eating food or drinking water contaminated with bacteria or parasites.

Medications, especially antibiotics, laxatives containing magnesium, and chemotherapy for cancer treatment, can also cause diarrhea.

The following medical conditions can also lead to diarrhea:

- Malabsorption syndromes such as lactose intolerance
- Inflammatory bowel diseases (Crohn's disease and ulcerative colitis)
- Irritable bowel syndrome (IBS)
- Celiac disease

Other less common causes of diarrhea include:

- Zollinger-Ellison syndrome
- Nerve disorders like autonomic neuropathy or diabetic neuropathy
- Carcinoid syndrome
- Gastrectomy (partial removal of the stomach)
- High dose radiation therapy



## Diarrhea p. 2

### Home Care

- Drink plenty of fluid to avoid becoming dehydrated. Start with sips of any fluid other than caffeinated beverages. Milk may prolong loose stools, but also provides needed fluids and nourishment. Drinking milk may be fine for mild diarrhea. For moderate and severe diarrhea, electrolyte solutions available in drugstores are usually best.
- Active cultures of beneficial bacteria (probiotics) make diarrhea less severe and shorten its duration. Probiotics can be found in yogurt with active or live cultures and in supplements.
- Foods like rice, dry toast, and bananas can sometimes help with diarrhea.
- Avoid over-the-counter anti-diarrhea medications unless specifically instructed to use one by your doctor. Certain infections can be made worse by these drugs. When you have diarrhea, your body is trying to get rid of whatever food, virus, or other bug is causing it. The medicine interferes with this process.
- Rest.

If you have a chronic form of diarrhea, like the one caused by irritable bowel syndrome, try adding bulk to your diet -- to thicken the stool and regulate bowel movements. Such foods include rice, bananas, and fiber from whole-wheat grains and bran. Psyllium-containing products such as Metamucil or similar products can also add bulk to stools.

### Call your health care provider if :

- You have blood or pus in your stools or your stool is black
- You have abdominal pain that is not relieved by a bowel movement
- You have symptoms of dehydration
- You have a fever above 101°F, or your child has a fever above 100.4°F, along with diarrhea
- You have foul smelling or oily-looking stools
- You have recently traveled to a foreign country
- You have eaten with other people who also have diarrhea
- You have started on a new medication
- Your diarrhea does not get better in 5 days (2 days for an infant or child), or worsens before that
- Your child has been vomiting for more than 12 hours (in a newborn under 3 months you should call as soon as vomiting or diarrhea begins)

### Prevention

- Wash your hands often, especially after going to the bathroom and before eating.
- Teach children to not put objects in their mouth.

## Diarrhea p. 3

- When taking antibiotics, try eating food with *Lactobacillus acidophilus*, a healthy bacteria. This helps replenish the good bacteria that antibiotics can kill. Yogurt with active or live cultures is a good source of this good bacteria.
- Use alcohol-based hand gel frequently

## References

Yates J. Traveler's diarrhea. *Am Fam Physician*. 2005; 71(11): 2095-2100.

Guerrant RL. Practice guidelines for the management of infectious diarrhea. *Clin Infect Dis*. 2001; 32(3): 331-351.

Update Date: 5/8/2006

Updated by: Jenifer K. Lehrer, MD, Department of Gastroenterology, Frankford-Torresdale Hospital, Jefferson Health System, Philadelphia, PA. Review provided by VeriMed Healthcare Network.

## Swimmer's ear

### Alternative names

Ear infection - outer ear - acute; Otitis externa - acute

### Definition

Swimmer's ear is an inflammation, irritation, or infection of the outer ear and ear canal.

### Causes, incidence, and risk factors

Swimmer's ear (otitis externa) is fairly common, especially among teenagers and young adults. Swimming in polluted water is one way to contract swimmer's ear. The condition also can be caused by scratching (in) the ear or by an object stuck in it. Trying to clean wax from the ear canal, especially with cotton swabs or small objects, can irritate or damage the skin.

Swimmer's ear is occasionally associated with middle ear infection (otitis media) or upper respiratory infections such as colds. Moisture in the ear makes the ear susceptible to infection from water-loving bacteria such as *Pseudomonas*. Other bacteria, and rarely, fungus, can also cause infection.

### Symptoms

- Ear pain -- may worsen when pulling the outer ear
- Itching of the ear or ear canal
- Drainage from the ear -- yellow, yellow-green, pus-like, or foul smelling

### Signs and tests

When the doctor looks in the ear, it appears red and swollen, including the ear canal. The ear canal may appear eczema-like, with scaly shedding of skin. Touching or moving the outer ear increases the pain. The eardrum may be difficult for the doctor to see with an otoscope because of the swollen outer canal. Taking some of the ear's drainage and doing a culture on it may identify bacteria or fungus.

### Treatment

The goal of treatment is to cure the infection. The ear canal should be cleaned of drainage to allow topical medications to work effectively.

## Swimmer's ear p. 2

Effective medications include ear drops containing antibiotics to fight infection, and corticosteroids to reduce itching and inflammation. Ear drops should be used abundantly (four or five drops at a time) in order to penetrate the end of the ear canal. If the ear canal is very swollen, a wick may be applied in the ear to allow the drops to travel to the end of the canal.

Occasionally, pills may be used in addition to the topical medications. Analgesics may be used if pain is severe. Putting something warm against the ears may reduce pain.

Protect ears from further damage. Do not scratch the ears or insert cotton swabs or other objects in the ears. Keep ears clean and dry, and do not let water enter the ears when showering, shampooing, or bathing.

### Expectations (prognosis)

Swimmer's ear responds well to treatment, but complications may occur if it is not treated. Some individuals with underlying medical problems, such as diabetes, may be more likely to get complications such as malignant otitis externa.

### Complications

- Chronic otitis externa
- Malignant otitis externa
- Spread of infection to other areas of the body

### Calling your health care provider

Call for an appointment with your doctor if you develop any symptoms of swimmer's ear. Call your doctor if the symptoms worsen or persist despite treatment, or if new symptoms appear, including pain and redness of the skull behind the ear or persistent fever.

### Prevention

- Dry the ear thoroughly after exposure to moisture.
- Avoid swimming in polluted water.
- Use earplugs when swimming.
- Consider putting a few drops of a 1:1 mixture of alcohol and white vinegar in the ears after they get wet. The alcohol and acetic acid prevent bacterial growth.

Update Date: 6/15/2005

Updated by: Monica Gandhi, MD, MPH, Assistant Professor, Division of Infectious Diseases, UCSF, San Francisco, CA. Review provided by VeriMed Healthcare Network.

<http://www.nlm.nih.gov/medlineplus/ency/article/000622.htm>

# Division of Parasitic Diseases

## ***Giardia* Infection**

### **Giardiasis (GEE-are-DYE-uh-sis)**

1 of 4

#### **What is giardiasis?**

Giardiasis (GEE-are-DYE-uh-sis) is a diarrheal illness caused by a one-celled, microscopic parasite, *Giardia intestinalis* (also known as *Giardia lamblia*). Once an animal or person has been infected with *Giardia intestinalis*, the parasite lives in the intestine and is passed in the stool. Because the parasite is protected by an outer shell, it can survive outside the body and in the environment for long periods of time.

During the past 2 decades, *Giardia* infection has become recognized as one of the most common causes of waterborne disease (found in both drinking and recreational water) in humans in the United States. *Giardia* are found worldwide and within every region of the United States.

#### **How do you get giardiasis and how is it spread?**

The *Giardia* parasite lives in the intestine of infected humans or animals. Millions of germs can be released in a bowel movement from an infected human or animal. *Giardia* is found in soil, food, water, or surfaces that have been contaminated with the feces from infected humans or animals. You **can** become infected after accidentally swallowing the parasite; you **cannot** become infected through contact with blood. *Giardia* can be spread by:

- Accidentally putting something into your mouth or swallowing something that has come into contact with feces of a person or animal infected with *Giardia*.
- Swallowing recreational water contaminated with *Giardia*. Recreational water includes water in swimming pools, hot tubs, jacuzzis, fountains, lakes, rivers, springs, ponds, or streams that can be contaminated with sewage or feces from humans or animals.
- Eating uncooked food contaminated with *Giardia*.
- Accidentally swallowing *Giardia* picked up from surfaces (such as bathroom fixtures, changing tables, diaper pails, or toys) contaminated with feces from an infected person.

#### **What are the symptoms of giardiasis?**

*Giardia* infection can cause a variety of intestinal symptoms, which include

- Diarrhea
- Gas or flatulence
- Greasy stools that tend to float
- Stomach cramps
- Upset stomach or nausea.

These symptoms may lead to weight loss and dehydration. Some people with giardiasis have no symptoms at all.

#### **How long after infection do symptoms appear?**

Symptoms of giardiasis normally begin 1 to 2 weeks (average 7 days) after becoming infected.

# Division of Parasitic Diseases

2 of 4

## **How long will symptoms last?**

In otherwise healthy persons, symptoms of giardiasis may last 2 to 6 weeks. Occasionally, symptoms last longer.

## **Who is most likely to get giardiasis?**

Anyone can get giardiasis. Persons more likely to become infected include

- Children who attend day care centers, including diaper-aged children
- Child care workers
- Parents of infected children
- International travelers
- People who swallow water from contaminated sources.
- Backpackers, hikers, and campers who drink unfiltered, untreated water
- Swimmers who swallow water while swimming in lakes, rivers, ponds, and streams
- People who drink from shallow wells

Contaminated water includes water that has not been boiled, filtered, or disinfected with chemicals. Several community-wide outbreaks of giardiasis have been linked to drinking municipal water or recreational water contaminated with *Giardia*.

## **What should I do if I think I may have giardiasis?**

See your health care provider.

## **How is a *Giardia* infection diagnosed?**

Your health care provider will likely ask you to submit stool samples to check for the parasite. Because *Giardia* can be difficult to diagnose, your provider may ask you to submit several stool specimens over several days.

## **What is the treatment for giardiasis?**

Several prescription drugs are available to treat *Giardia*. Although *Giardia* can infect all people, young children and pregnant women may be more susceptible to dehydration resulting from diarrhea and should, therefore, drink plenty of fluids while ill.

## **My child does not have diarrhea, but was recently diagnosed as having giardiasis. My health care provider says treatment is not necessary. Is this true?**

Treatment is not necessary when the child has no symptoms. However, there are a few exceptions. If your child does not have diarrhea, but is having nausea, fatigue (very tired), weight loss, or a poor appetite, you and your health care provider may wish to consider treatment. If your child attends a day care center where an outbreak is continuing to occur despite efforts to control it, screening and treating children who have no obvious symptoms may be a good idea. The same is true if several family members are ill, or if a family member is pregnant and therefore not able to take the most effective anti-*Giardia* medications.

## **If I have been diagnosed with giardiasis, should I worry about spreading the infection to others?**

# Division of Parasitic Diseases 3 of 4

Yes, a *Giardia* infection can be very contagious. Follow these guidelines to avoid spreading giardiasis to others:

1. Wash your hands with soap and water after using the toilet, changing diapers, and before eating or preparing food.
2. Do not swim in recreational water (pools, hot tubs, lakes or rivers, the ocean, etc.) if you have *Giardia* and for at least 2 weeks after diarrhea stops. You can pass *Giardia* in your stool and contaminate water for several weeks after your symptoms have ended. This has resulted in outbreaks of *Giardia* among recreational water users.
3. Avoid fecal exposure during sexual activity.

## **How can I prevent a *Giardia* infection?**

### **Practice good hygiene.**

1. Wash hands thoroughly with soap and water.
  - a. Wash hands after using the toilet and before handling or eating food (especially for persons with diarrhea).
  - b. Wash hands after every diaper change, especially if you work with diaper-aged children, even if you are wearing gloves.
2. Protect others by not swimming if you are experiencing diarrhea (essential for children in diapers).

### **Avoid water that might be contaminated.**

1. Do not swallow recreational water.
2. Do not drink untreated water from shallow wells, lakes, rivers, springs, ponds, and streams.
3. Do not drink untreated water during community-wide outbreaks of disease caused by contaminated drinking water.
4. Do not use untreated ice or drinking water when traveling in countries where the water supply might be unsafe.

In the United States, nationally distributed brands of bottled or canned carbonated soft drinks are safe to drink. Commercially packaged non-carbonated soft drinks and fruit juices that do not require refrigeration until after they are opened (those that are stored unrefrigerated on grocery shelves) also are safe.

### **If you are unable to avoid using or drinking water that might be contaminated, then you can make the water safe to drink by doing one of the following:**

- Heat the water to a rolling boil for at least 1 minute, OR
- Use a filter that has an absolute pore size of at least 1 micron or one that has been NSF rated for "cyst removal."
- If you cannot heat the water to a rolling boil or use a recommended filter, then try chemically treating the water by chlorination or iodination.

For information on recreational water-related illnesses, visit CDC's Healthy Swimming website at <http://www.cdc.gov/healthyswimming>.

For information on choosing safe bottled water, see the CDC fact sheet entitled "Preventing Cryptosporidiosis: A Guide to Water Filters and Bottled Water," available by visiting <http://www.cdc.gov/ncidod/dpd/parasites/cryptosporidiosis/>

# Division of Parasitic Diseases

4 of 4

Using chemicals may be less effective than boiling or filtering because the amount of chemical required to make the water safe is highly dependent on the temperature, pH, and cloudiness of the water.

## **Avoid food that might be contaminated.**

1. Wash and/or peel all raw vegetables and fruits before eating.
2. Use safe, uncontaminated water to wash all food that is to be eaten raw.
3. Avoid eating uncooked foods when traveling in countries with minimal water treatment and sanitation systems.

## **Avoid fecal exposure during sexual activity.**

### **If my water comes from a well, should I have my well water tested?**

You should consider having your well water tested if you can answer “yes” to any of the following questions:

- **Are members of your family or others who use your well water becoming ill?**

If yes, your well may be the source of infection.

- **Is your well located at the bottom of a hill or is it considered shallow?**

If so, runoff from rain or flood water may be draining directly into your well causing contamination.

- **Is your well in a rural area where animals graze?** Well water can become contaminated with feces if animal waste seepage contaminates the ground water. This can occur if your well has cracked casings, is poorly constructed, or is too shallow. Tests used to specifically identify *Giardia* are often expensive, difficult, and usually require hundreds of gallons of water to be pumped through a filter. If you answered “yes” to the above questions, consider generally testing your well for fecal contamination by testing it for the presence of coliforms or *E. coli* instead of *Giardia*. Although tests for fecal coliforms or *E. coli* do not specifically tell you whether *Giardia* is present, these tests will show whether your well water has been contaminated by fecal matter. These tests are only useful if your well is not routinely disinfected with chlorine, since chlorine kills fecal coliforms and *E. coli*. If the tests are positive, it is possible that the water may also be contaminated with *Giardia* or other harmful bacteria and viruses.

Contact your county health department, your county cooperative extension service, or a local laboratory to find out who offers water testing in your area. If the fecal coliform test comes back positive, indicating that your well is fecally contaminated, discontinue drinking the well water and contact your local water authority for instructions on how to disinfect your well.

*This fact sheet is for information only and is not meant to be used for self-diagnosis or as a substitute for consultation with a health care provider. If you have any questions about the disease described above or think that you may have a parasitic infection, consult a health care provider.*

For information on choosing a water filter, see the CDC fact sheet entitled

“Preventing Cryptosporidiosis: A Guide to Water Filters and Bottled Water,” available by visiting [http://www.cdc.gov/ncidod/dpd/parasites/cryptosporidiosis/factsht\\_crypto\\_prevent\\_water.htm](http://www.cdc.gov/ncidod/dpd/parasites/cryptosporidiosis/factsht_crypto_prevent_water.htm).



# **CHEERS QAPP 3**

## **Appendix 8: Low Cost Clinics in Chicago**

**Low Cost Health-Care Providers**  
**Chicago, IL**

<b>Name</b>	<b>Location</b>	<b>Phone #</b>
<b>South/Southwest Chicago</b>		
Access Ashland Family Health Center	5256 S. Ashland Avenue	773-434-9216
Access Auburn-Gresham Family Health Center	8234 S. Ashland Avenue	773-874-1400
Access Booker Family Health Center	747 E. 47th Street	773-624-4800
Access Brandon Family Health Center	8300 S. Brandon Avenue	773-721-7600
Access Grand Family Health Center	5401 S. Wentworth Avenue	773-288-6900
Access Ideal Family Health Center	2413 S. State Street	312-225-6800
Access South State Family Health Center	5050 S. State Street	773-624-2700
Access Southwest Family Health Center	4839 W. 47th Street	773-735-2345
Access Taylor Family Health Center	4501 S. State Street	773-548-0800
Access Wells Family Health Center	3747 S. Cottage Grove	773-536-1000
CDPH Englewood Family Health Center	641 W. 63rd Street	312-747-7831
CDPH Roseland Neighborhood Health Center	200 E. 115th Street	312-747-9500
CDPH South Chicago	2938 E. 89th Street	312-747-5285
Chicago Family Health Center - Roseland	556 E. 115th Street	773-785-6800
Chicago Family Health Center- South Chicago	9119 S. Exchange Avenue	773-768-5000
Christian Community Health Center	9718 S. Halsted Street	773-233-4100
Cook County Woodlawn Health Center	6337 S. Woodlawn	312-747-7700
Cook County Englewood Health Center	1135 W. 69th Street	773-483-5090
Friend Family Health Center - East	800 E. 55th Street	773-702-0660
Friend Family Health Center - West	5843 S. Western Avenue	773-434-8600
Holy Cross Family Medical Center	2701 W. 68th Street	773-884-3400
John Sengstacke Health Center	450 E. 51st	312-572-2900
Komed/Holman Health Center	4259 S. Berkeley Avenue	773-268-7600
TCA Health Center	1029 E. 130th Street	773-995-6300
University of Chicago Friend & Family Center	800 E. 55th Street	773-702-0660

## West Chicago

Access Armitage Family Health Center	2957 W. Armitage Avenue	773-772-4319
Access Austin Family Health Center	5835 W. North Avenue	773-745-1200
Access Cabrini Family Health Center	1858 W. 35th Street	773-523-1000
Access Centro Medico	3700 W. 26th Street	773-542-5203
Access Centro Medico San Rafael	3204 W. 26th Street	773-927-3100
Access Doctors Medical Group	6240 W. 55th Street	773-284-2200
Access Dr. James West Clinic at Haymarket Center	120 N. Sangamon Street	312-226-7984 x408
Access Humboldt Park Family Health Center	3202 W. North Avenue	773-489-6333
Access Jackson Family Health Center	2450 W. Jackson Boulevard	773-829-7650
Access Kedzie Family Health Center	3213-21 W. 47th Place	773-254-6044
Access Lawndale Family Health Center	1108 S. Kedzie Avenue	773-722-2712
Access Madison Family Health Center	3800 W. Madison	773-826-6600
Access Near West Family Health Center	1158 W. Taylor Street	312-455-8640
Access Pilsen Family Health	1817 S. Loomis Street	312-666-6511
Access Plaza Medical Center	2507 W. Cermak Road	773-523-0900
Access Servicios Medicos La Villita	3303 W. 26th Street	773-277-6589
Access Warren Family Health Center	2409 W. Warren Boulevard	312-733-4475
Access West Division Family Health Center	4401 W. Division Street	773-252-3122
Access Westside Family Health Center	3606 W. 16th Street	773-762-2435
Alivio Medical Center	966 W. 21st Street	312-829-6304
Alivio Medical Center	2355 S. Western Avenue	773- 254-1400
Logan Square Health Center	1108 S. Kedzie	773-722-2712
CDPH Lower West Side	1713 S. Ashland	312-746-5157
CDPH South Lawndale	3059 W. 26th St.	312-747-0066
Circle Family Care	4909 W. Division Street	773-921-8100
Cook County Austin Health Center	4800 W. Chicago Ave.	773-826-9600
Cook County Cicero Health Center	5912 W. Cermak	708-783-9800
Cook County Fantus Health Center	621 S. Winchester	312-864-6224
Erie West Side Family Health Center	646 N. Lawndale Avenue	312-666-3494
Lawndale Christian Health Center - Arthington	3517 W. Arthington Street	773-843-3000
Lawndale Christian Health Center - Farragut	2345 S. Christiana Avenue	773-843-3000
Lawndale Christian Health Center - Ogden	3860 W. Ogden Avenue	773-843-3000
Louise Landau Health Center	3645 W. Chicago Avenue	773-826-3450

## North/Northwest Chicago

Access Anixter Center	2020 N. Clybourn Avenue	773-404-5277
Access Evanston-Rogers Park Family Health Center	1555 W. Howard Street	773-764-3425
Access Humboldt Park Family Health Center	3202 W. North Avenue	773-278-1880
Access Near North Family Health Center	361 W. Chestnut Street	312-751-4080
Access Peterson Family Health Center	2655 W. Peterson Avenue	773-271-8880
CDPH Lakeview Neighborhood Health Center	2849 N. Clark Street	(773) 528-1188
CDPH Uptown Neighborhood Health Center	845 W. Wilson	312-744-1938
CDPH West Town Neighborhood Health Center	2418 W. Division Street	312-744-0943
Chicago Health Outreach	1015 W. Lawrence Avenue	773-275-2586
Circle Family Care	118 N. Central Avenue	773-921-1446
Erie Helping Hands Health Center	4759 N. Kedzie	773-588-9640
Erie Humboldt Park Family Health Center	2750 W. North Avenue	312-666-3494
Erie West Town Family Health Center	1701 W. Superior Street	312-666-3494
Health Service Center	4909 W. Division Street	773-921-8100
James Jordan Family Life Center	2102 W. Madison Street	312-226-2323
Miles Square Health Center	2045 W. Washington Boulevard	312-413-7810
Near West Family Health Center	2310 W. Roosevelt Road	773-432-4087
PCC Austin Family Health Center	355 N. Mason Avenue	773-378-3347
PCC Lake Street Family Health Center	14 Lake Street	773-921-8100
PCC Salud Family Health Center	5359 W. Fullerton Avenue	773-836-2785
PrimeCare Community Wellness - Northwest	4235 W. North Avenue	773-278-6868
PrimeCare Community Wellness - West Logan Square	3924 W. Fullerton Avenue	773-276-2229
PrimeCare Community Wellness - West Town	1431 N. Western Avenue	312-633-5841
Winfield Moody Health Center	1276 N. Clybourn Avenue	312-337-1073

<b>Chicago Suburbs</b>		
Access Alma Family Health Center	318 Madison Street Maywood, IL 60153	708-344-5300
Access Blue Island Family Health Center	13000 Maple Avenue Blue Island, IL 60406	708-385-6100
Access Cicero Family Health Center	5817 W. Cermak Road Cicero, IL 60804	708-458-0757
Access Des Plaines Valley Health Center	7450 W. 63rd Street Summit, IL 60501	708-458-0757
Access Family Health Society	152 W. Lincoln Highway Chicago Heights, IL 60411	708-754-9687
Access Genesis	1 N. Broadway Street Des Plaines, IL 60440	847-298-3150
Access Hawthorne Family Health Center	2307-09 S. Cicero Avenue Cicero, IL 60804	708-780-9777
Access Maywood Family Health Center	318 West Madison St. Maywood, IL 60153	708-344-5300
Access Melrose Park Family Health Center	8321 W. North Avenue Melrose Park, IL 60160	708-681-2298
Belvidere Medical Building	2400 Belvidere Road Waukegan, IL 60085	847-360-6500
Medical Services Northeast Satellite	1819 27th Street Zion, IL 60099	847-872-1918
<b>Vincennes Health Center</b>	1644 Vincennes Avenue Chicago Heights, IL 60411	708-756-2001

# **CHEERS QAPP 3**

## **Appendix 9: Specimen Chain of Custody Log**



# **CHEERS QAPP 3**

## **Appendix 10: UIC Laboratory: Stool Culture**



## **STOOL CULTURE**

### **PRINCIPLE:**

Acute infectious diarrhea is caused by a number of different agents: bacteria, viruses, and protozoa. The laboratory routinely searches for the bacteria that are most likely to cause diarrhea. Stool specimens are cultured in order to isolate one or more of the following pathogens: *Salmonella*, *Shigella*, *Edwardsiella*, *Yersinia*, *Aeromonas*, *Plesiomonas*, *Vibrio*, *Campylobacter*, and *E. coli* 0157:H7. *Campylobacter jejuni* is the most important species of *Campylobacter* in terms of human disease, usually causing diarrhea (sometimes with blood in the stool), abdominal pain, nausea, fever, and sometimes vomiting. The most common sources of infection are unpasteurized milk, and rare or partially cooked poultry. Several new *Campylobacter* species have been discovered and are associated with new clinical syndromes. In addition, a predominance of yeast, *Staphylococcus aureus*, beta streptococci, or *Pseudomonas aeruginosa* may be clinically significant.

Normal stool flora consists of a variety of gram positive and gram negative organisms. In order to isolate and identify pathogens, a combination of selective and differential media, biochemical tests, and serological typing are employed. Isolation of *Campylobacter jejuni/coli* depends on the use of selective media, a microaerophilic atmosphere (5% O<sub>2</sub>, 10% CO<sub>2</sub>, 85% N<sub>2</sub>) and growth optimally at 42°C. One selective media used is Campy BAP which is a brucella agar base with 10 % sheep blood. The agar contains a variety of antibiotics which prevent or retard the growth of competing enteric flora. A selective enrichment broth is also used to recover low numbers of organisms. The organisms are slender, spirally curved gram negative rods which appear as non-hemolytic clear or gray colonies on the media. Colonies may appear at 24 to 72 hours of incubation.

### **SPECIMEN:**

#### **Acceptable Specimens:**

1. Freshly passed stool. For optimal recovery of organisms, collect specimen during the acute stage (first 3 days) of diarrheal disease, prior to antibiotic therapy.
2. Rectal swabs. Swabs will not yield maximal number or positive cultures. Should be primarily used to sample feces flora from persons ill in an epidemic or from infants. Single rectal swabs are of little value in examination of convalescent patients.
3. Acceptable containers: Plastic stool container, Cairy Blair Transport, Culturette

*University of Illinois Medical Center at Chicago  
Pathology Laboratories  
Clinical Microbiology Laboratory*

**Unacceptable Specimens:**

1. More than one specimen per day
2. Specimen collected after 3 hospital day
3. Specimens received in diapers
4. Specimens received >24 in transit. Specimens received in Cary Blair can be held for up to 3 days at room temperature.
5. Dried specimens

**EQUIPMENT AND MATERIALS:**

**Equipment:**

Campy jar  
Campy gas generator  
42° C incubator  
35° C incubator

**Materials:**

Blood Agar Plate (BAP)  
Hektoen Enteric Agar Plate (HE)  
MacConkey Agar Plate (MAC)  
Campylobacter BAP (CVA)  
Campylobacter Thioglycollate

**QUALITY CONTROL:**

**Materials:**

3 CVA agar plates  
2 Campylobacter Thioglycollate  
Tryptic Soy Broth (TSB)  
Sterile swabs  
Sterile tubes  
Sterile saline

**University of Illinois Medical Center at Chicago**  
**Pathology Laboratories**  
**Clinical Microbiology Laboratory**

10 ul loops

Quality control is to be performed on each new shipment of CVA and Campylobacter Thioglycollate. The organisms to be used for Quality Control testing are the following:

*Campylobacter jejuni* ATCC 33291  
*Staphylococcus epidermidis* ATCC 14990  
*Candida albicans* ATCC 10231  
*Escherichia coli* ATCC 25922

These isolates are frozen at -70°C. These organisms are subcultured to a blood agar plate when quality control testing is to be performed. The organisms are streaked for isolation and incubated at 35 - 37°C or 42°C. The organisms are to be subcultured at least three times prior to testing. The organisms may then be set up for testing using the following instructions:

1. Designate plates and inoculate as follows:

CVA	:	(# 1)	1/2 <i>C. jejuni</i> 1/2 <i>E. coli</i>
		(# 2)	1/2 <i>S. epidermidis</i> 1/2 <i>C. albicans</i>
		(# 3)	Sterility
Campy Thio:		(#1)	<i>C. jejuni</i>
		(#2)	<i>Sterility</i>

2. To perform QC for the CVA prepare the following suspension:
  - a. Obtain fresh stock cultures. Suspend several isolated colonies in TSB to match the turbidity of a 0.5 McFarland standard.
  - b. Dilute the basic cell suspension 1:10 in sterile normal saline (9 ml saline with 1 ml of the cell suspension added).
  - c. Inoculate each organism suspension to the CVA using a 10 ul loop (0.01 ml disposable blue loop) or 10 ul MLA pipette.

**University of Illinois Medical Center at Chicago**  
**Pathology Laboratories**  
**Clinical Microbiology Laboratory**

- d. Incubate as described in Campy gas at 42°C.
  - e. Examine plates at 24 and 48 hours. Record reactions in the appropriate log sheets, initial and date.
3. To perform QC for the *Campylobacter* Thioglycollate prepare the following suspension:
- a. Obtain a fresh subculture of *C. jejuni*. Suspend several isolated colonies in TSB to match the turbidity of a 0.5 McFarland Standard.
  - b. Dilute the basic cell suspension 1:10 in sterile normal saline (9 ml saline with 1 ml cell suspension added).
- \*\*\*If QC is performed in conjunction with the CVA procedure, the same *C. jejuni* suspension can be used \*\*\*
- c. Inoculate the suspension to the *Campylobacter* Thioglycollate using a 10 ul loop or 10 ul MLA pipette.
  - d. Refrigerate at 2 – 8° C for 18 to 24 hours.
  - e. After 18-24 hours refrigeration, subculture to a CVA, as described in **PROCEDURE:Subculture of Campy Thioglycollate.**
  - f. Examine subcultured plates after 24 and 48 hours. Record reactions in appropriate log sheets, initial and date.
4. Expected Reactions for CVA and *Campylobacter* Thioglycollate are as follows:

<u>ORGANISMS</u>	<u>EXPECTED REACTIONS</u>
<i>C. jejuni</i>	Vigorous growth
<i>E. coli</i>	Weak or no growth
<i>S. epidermidis</i>	Weak or no growth
<i>C. albicans</i>	Weak or no growth
Sterility	No growth

If any deficiencies are observed, notify supervisor for appropriate action. Any corrective action taken should be noted on the QC worksheet.

**STORAGE REQUIREMENTS:**

**University of Illinois Medical Center at Chicago**  
**Pathology Laboratories**  
**Clinical Microbiology Laboratory**

All media is to be stored at 2 to 8° C.

**PROCEDURE - STEPWISE:**

A. Culture Examination and Interpretation of Aerobic Cultures (non-campylobacter)

1. Examine original BAP, MAC, and HE plates at both 24 and 48 hours incubation.
2. Look for "suspicious colonies" on each plate as follows:

<b>PLATE</b>	<b>SUSPICIOUS COLONIES</b>
--------------	----------------------------

BAP	Predominance of yeast, <i>Staphylococcus aureus</i> , beta streptococci, or <i>Pseudomonas aeruginosa</i> , β hemolytic gram negative rods (screen with oxidase)
-----	--

MAC	Lactose negative colonies (clear to pink colonies)
-----	--

HE	Lactose negative and/or H <sub>2</sub> S positive colonies (clear colonies with or without black centers, or black colonies)
----	--

3. Work up suspicious colonies as follows:
  - a. Yeast - gram stain only
  - b. *S. aureus* - staphaurex
  - c. Beta streptococci - slidex
  - d. Lactose negative - inoculate Kliglers and LIA
  - f. H<sub>2</sub>S positive - inoculate Kliglers and LIA

Refer to appropriate procedure for instructions on these tests.

4. Interpretation of Kligler's iron agar and LIA reactions for stool cultures
  - a. Read reactions of Kliglers and LIA as described in their procedures.
  - b. Using Stool Cultures Flow Chart, incorporate KL and LIA reactions. Follow directions on flowchart, and perform tests indicated. (Refer to appropriate procedures for information on performing tests.)

**University of Illinois Medical Center at Chicago**  
**Pathology Laboratories**  
**Clinical Microbiology Laboratory**

5. Cultures positive for *Salmonella* and *Shigella*
  - a. All isolates must be sent to IDPH for further serological differentiation. Streak organisms to a tryptic soy agar slant and refer to procedure for sending specimens to IDPH.
  - b. It is not necessary to retype multiple identical isolates on the same culture if one has already typed positive. Do not send multiple isolates to IDPH.

**B. Culture Examination and Interpretation of *Campylobacter* Cultures**

**Examination of Direct Plates:**

1. Examine direct plates at 24, 48, and 72 hours of incubation. Examine the Campy thioglycollate subculture plates at 24 hours and 48 hours. Look for gray or colorless, nonhemolytic colonies that may be either flat and watery with irregular edges, or round and convex with entire edges. The colonies may range in size from pinpoint to large and spready.  
**1**  
Treat these organisms like anaerobes. Examine plates quickly and place them back into special gas mixture.
2. Gram stain any suspicious colonies, leave safranin on slide for about 3 minutes.  

*Campylobacter* organisms may appear as:

  - a) comma shaped
  - b) s-shaped
  - c) long spirals
  - d) gull winged shaped
3. If gram stain correlates, perform oxidase and catalase test on suspicious colony. *Campylobacter jejuni/coli* will be oxidase and catalase positive (reactions may be weak).
4. If colony has typical morphology on plate, appropriate gram stain, and is oxidase and catalase positive, report as presumptive *Campylobacter* species. Notify floor or clinic.
5. Obtain a blood agar plate. Inoculate plate and streak for isolation.

**University of Illinois Medical Center at Chicago**  
**Pathology Laboratories**  
**Clinical Microbiology Laboratory**

6. Place a Nalidixic acid disk on the first quadrant of the plate.
7. Place the plate a Campy jar. Open Campy generator and place inside jar. Quickly close top.
8. Incubate plates at 42°C.
9. Examine plate at 24 and 48 hours.
10. From the subculture plate, perform a rapid Sodium Hippurate (See Aerobic Procedure Manual for procedure).

**Subculture of Campy Thioglycollate:**

**MATERIALS:**

Sterile plastic pasteur pipette (with bulb attached)  
CVA  
Campy jar  
Campy generator  
Inoculating loop

1. After 18-24 hours refrigeration at 2 - 8°C, remove Campylobacter Thioglycollate.
2. Place the tip of a sterile plastic pasteur pipette approximately one inch below the surface of thioglycollate
3. Withdraw an aliquot towards the surface the tube.
4. Invert pipette and mix contents in bulb.
5. Place 2-3 drops of specimen on CVA and streak for isolation.
6. Place plate in Campy Jar. Place Campy generator in jar and quickly close the top. Incubate at 42°C.
7. Place only 6 - 8 plates per jar.

**Interpretation of Positive Campylobacter Cultures:**

*Campylobacter jejuni* will produce the following reactions:

*University of Illinois Medical Center at Chicago  
Pathology Laboratories  
Clinical Microbiology Laboratory*

<u>TEST</u>	<u>REACTION</u>
42° growth	( + )
Nalidixic Acid Disk	S
Sodium Hippurate	( + )

*Campylobacter coli* will produce the following reactions:

<u>TEST</u>	<u>REACTION</u>
42° growth	( + )
Nalidixic Acid Disk	S
Sodium Hippurate	( - )

If any other results occur or the organism grows at 35°C **only**, bring to the attention of the supervisor or lab rounds.

**REPORTING RESULTS:**

The workup and reporting of Stool Cultures is to include the reporting of (or absence of) normal stool flora, reporting of no growth, reporting of the absence of coliforms as part of sparse normal stool flora, and the exclusion of workup for gram positive stool flora. When reporting stool flora and negative for enteric pathogens, use to precoded statements in Mysis.

The precoded results are:

1. *Normal Stool Flora, Negative for Enteric Pathogens including Campylobacter, Salmonella, Shigella, Yersinia, Edwardsiella, Aeromonas, and Pleiomonas.* Use this result when the following conditions have been met:
  - a. absence of pathogens
  - b. moderate to many lactose positive gram negative rods
  - c. no beta hemolytic oxidase positive gram negative rods



**University of Illinois Medical Center at Chicago**  
**Pathology Laboratories**  
**Clinical Microbiology Laboratory**

- d. Presence or absence of any one of the following: rare to few yeast, rare to few *Staphylococcus aureus*, any amount of gram positive organisms (not yeast or *S. aureus*).
2. *No growth*. Use this result for no growth cultures.
3. *Sparse Normal Stool Flora, Negative for Enteric Pathogens including Campylobacter, Salmonella, Shigella, Yersinia, Edwardsiella, Aeromonas, and Pleiomonas*. Use this result when the following conditions have been met:
  - a. absence of pathogens
  - b. rare to few lactose positive gram negative rods rare to few yeast, rare to few *Staphylococcus aureus*
  - c. no beta hemolytic oxidase positive gram negative rods
  - d. Presence or absence of any one of the following: rare to few yeast, rare to few *Staphylococcus aureus*, any amount of gram positive organisms (not yeast or *S. aureus*).
4. *Sparse Normal Stool Flora, No Coliforms Present, Negative for Enteric Pathogens including Campylobacter, Salmonella, Shigella, Yersinia, Edwardsiella, Aeromonas, and Pleisiomonas*. Use this result when the following conditions have been met:
  - a. absence of pathogens
  - b. absence of fermenting gram negative rods
  - c. no beta hemolytic oxidase positive gram negative rods
  - d. Presence or absence of any one of the following: rare to few yeast, rare to few *Staphylococcus aureus*, any amount of gram positive organisms (not yeast or *S. aureus*).
5. Yeast and *Staphylococcus aureus* are part of stool flora and will be reported using the criteria:

Yeast will be reported if it is found to be in pure culture or the predominating organism. No germ tube or further workup is required unless a physician requests identification. If yeast is found in pure culture, none of the precoded results can be used. Report the absence of stool flora, the quantity of yeast, and negative for enteric pathogens. If yeast is the predominant organism, use one of the precoded results to report the type of normal flora, then report the quantity of yeast.

6. *Staphylococcus aureus* will be reported if it is found to be in pure culture or the predominating organism. No susceptibility is required. If *S. aureus* is found in pure culture, none of the precoded results can be used. Report the absence of stool flora, quantity of

**University of Illinois Medical Center at Chicago**  
**Pathology Laboratories**  
**Clinical Microbiology Laboratory**

staph, and negative for enteric pathogens. If *S. aureus* is the predominant organism, use one of the precoded results to report the type of normal flora, then report the quantity of staph.

7. *Pseudomonas aeruginosa* is identified when found to be the predominant gram negative rod. No susceptibility is required. When reporting, use one of the precoded results to report the type of normal flora, then report the quantity of pseudo.
8. When reporting a stool pathogen, DO NOT use any of the precoded results. There is no reason to report the presence of stool flora.
9. **Organism identifications done by IDPH or CDC must be stated on the CULTURE report.** There are precoded comments for IDPH and CDC in Mysis. These precoded comments must be used along with the confirmed identification of an organism. Example: *Salmonella serotype enteritidis*. Identification confirmed by the Illinois Department of Health Lab, Chicago, Illinois.

**REFERENCES:**

Murray et al. 2007. *Manual of Clinical Microbiology*, 9th ed. American Society for Microbiology, Washington D.C.

Isenberg, Henry D. 1992. *Clinical Microbiology Procedures Handbook*. American Society for Microbiology, Washington, D.C.

Winn et al. 2006. Koneman's *Color Atlas and Textbook of Diagnostic Microbiology*, 6th ed. Lippincott-Raven, Philadelphia, PA.

NCCLS: Quality Assurance for Commercially Prepared Microbiological Culture Media. (Approved Standard, Third Edition, M22-A3). NCCLS, Villanova, Pa, 2004.

University of Illinois Medical Center at Chicago  
 Pathology Laboratories  
 Clinical Microbiology Laboratory

Cont'd from Page 1, H2S neg, Oxidase neg, Glucose pos or weak

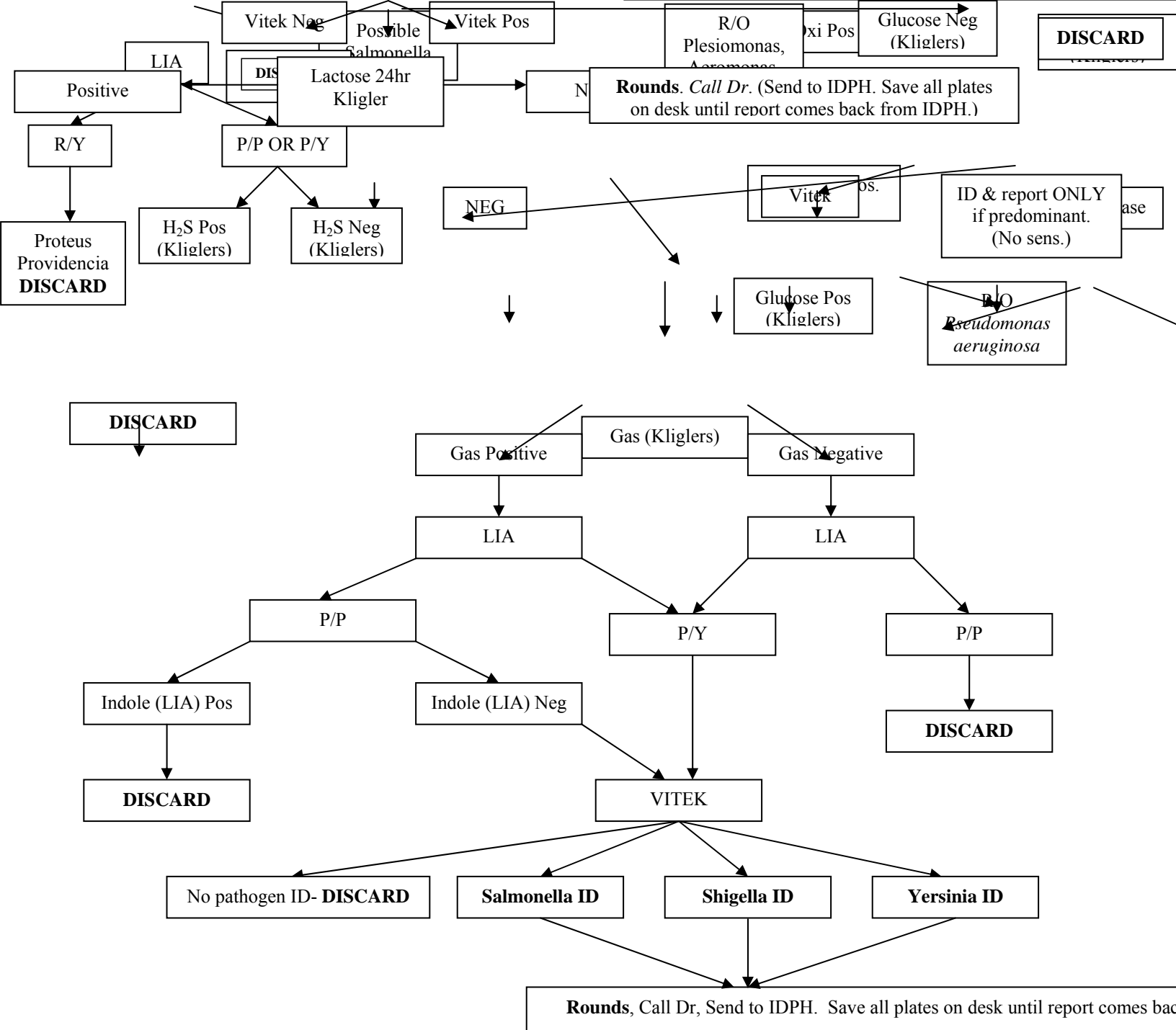

# **CHEERS QAPP 3**

## **Appendix 11: UIC Laboratory: Stool Viral Culture**

### **A: Virus isolation and identification procedures**

## **VIRUS ISOLATION AND IDENTIFICATION PROCEDURES**

### **INTRODUCTION:**

A variety of methods are used for the laboratory diagnosis of viral infections. These include isolation in cell culture; direct examination of clinical material to detect viral particles, antigens, or nucleic acids; cytohistological evidence of infection; and serologic assays to assess the individual's antibody response to infection. No single approach can meet the needs of the diagnostic virology laboratory. Instead, a combination of methods must be implemented. The choice of methods involves several factors, including knowledge of the pathogenesis of the suspected agent(s), the stage of illness, and the availability and utility of various methods for the particular infection in question.

The field of clinical virology is changing rapidly and a wide variety of testing methodologies are now available for virus detection. Cell culture isolation, the backbone of the virology laboratory, has also changed significantly in the past 10 years. The introduction of the centrifugation-enhanced (shell vial) technique has for the first time, allowed laboratories to provide culture confirmation within a clinically relevant time frame for many slow-growing viruses.

Rapid identification of viral agents is becoming increasingly important because of the development and use of antiviral agents. Unfortunately, the conventional method of virus isolation in standard tube culture can take up to 21 days. The shell vial technique which combines centrifugation with monoclonal antibody staining has further reduced the time for virus detection. However, due to the limited optimum sensitivity of a single cell line preparation for different viral pathogens, several cell lines along with primary monkey kidney cells are often included for conventional tube or shell vial culture. This practice is both costly and time consuming. Recently mixed cell cultures have come on the market that ultimately can save time and money.

### **PRINCIPLE:**

Viruses are obligate intracellular parasites and require a suitable cell culture substrate for propagation. Since there is no one cell type that will support the replication of all viruses, a spectrum of different cell types is used to cultivate the medically important viruses. Certain viruses, including Epstein-Barr virus and human immunodeficiency virus type 1 are not culturable in traditional mono-layered cell cultures and require the use of blood WBCs. Several other viruses remain unculturable or require specialized cell cultures or alternative hosts that are not generally available in the diagnostic setting. Several Coxsackie A viruses, rabies virus, and arbovirus are best isolated in mice. In some instances, noninfectious subviral particles may be present in cells. These are not recoverable by conventional isolation procedures. For example, the recovery of measles virus from the brain tissue of patients with subacute sclerosing

*University of Illinois Medical Center at Chicago*  
*Pathology Laboratories*  
*Clinical Microbiology Laboratory*

panencephalitis was achieved by co-cultivation involving the fusion of brain cells with cell cultures.

Once a specimen is received in the laboratory, it is processed to yield material suitable for the inoculation into shell vial cultures. Specimen preparation depends on the specimen type. Swabs are vortexed in viral transport medium, tissue samples are homogenized, and fluid specimens usually require only the addition of antimicrobial agents. After specimens are inoculated into the appropriate cell cultures, the cultures are incubated at 35 – 37°C. A major emphasis in recent years has been on providing culture results within the shortest possible time.

**SPECIMEN COLLECTION:**

Successful laboratory diagnosis of viral infections requires an understanding of the pathogenesis of the suspected organism and knowledge regarding the stage of infection and the age and immunocompetence of the infected individual. The success of culture depends on several factors including the proper choice of specimens, careful collection to optimize recovery of the agent, and transport of specimens in a manner that maintains viability and minimizes overgrowth with contaminating organisms. For best correlation with a particular disease, the specimen should reflect the target organ whenever possible.

- A) Special transport media is available for specimen collection.
- B) All specimens are processed immediately upon receipt.
- C) Those specimens received outside normal working hours are kept at 2 – 8°C until processed.
- D) All handling and processing of virology specimens must be done under a class II biological safety cabinet in accordance with the universal precautions for blood-borne pathogens. Refer to the Laboratory Safety Manual for specific details.
- E) Specimen Rejection Criteria
  - 1. All specimens received without an attached identifying label, or label that does not correspond with the information provided on the accompanying requisition or transmittal form, will not be tested until the requesting physician is contacted and asked to either personally identify and label the specimen or submit a new specimen. If the physician requests that the test be performed on the improperly labeled specimen, all subsequent reports will include a comment to the effect.
  - 2. All specimens submitted for viral isolation must be collected according to instructions outlined in the Laboratory Users Guide. All requests for viral isolation must include the source of specimen and if possible the type of infection and/or the virus expected. Dry swabs will not be accepted by the virology lab. All virology specimen transport kits contain detailed instructions for each type of patient specimen that needs to be collected. The clinician is

*University of Illinois Medical Center at Chicago*  
*Pathology Laboratories*  
*Clinical Microbiology Laboratory*

also encouraged to contact the laboratory if any additional instruction is needed. The requesting physician will be notified and asked to submit a properly collected specimen if necessary.

3. Grossly contaminated specimen containers and/or soiled requisition will not be accepted. Any spillage is treated with the proper disinfectant and all contaminated materials disposed in an appropriate biohazard bag. If possible, another specimen should be submitted following notification of the requesting physician. The head nurse on the patient's unit will be notified of all improperly collected and/or transported specimens.
4. "QNS" specimens: The requesting physician will be notified by telephone and a canceled test report will be sent out in the computer. If more than one test is requested, the tests to be performed will be prioritized in consultation with the requesting physician.

**PROCEDURE:**

A) Collection and Processing of Clinical Specimens—See Specimen Collection section.

B) Inoculation and Examination of Cell Cultures

- 1) All routine specimens are inoculated into a cell spectrum of at least two (unless otherwise specified) cell types to ensure cell susceptibility and virus recovery.
- 2) Uninoculated cell culture controls from each new lot are incubated along with the patients. When new cells are checked into the laboratory, a record is kept of cell type, passage number, and source. Observe the gross and microscopic conditions of the cultures. Inspect the cultures for leaking, breakage, pH extremes, contamination, etc. Microscopically examine representative monolayer to assess the quality and extent of development (sparse, sub confluent, confluent, overgrown). Record any problems and if necessary, notify the technical service of the manufacturer.
- 3) Patient and control cell cultures are incubated at 35 – 37°C in exactly the same manner as patients.
- 4) **All cultures, including controls, are examined every working day for the appearance of cytopathic effects (CPE).** The cultures are held 1 – 7 days prior to issuing a negative report. Preliminary positive results are entered in the computer and are also reported by telephone (except for HSV request from the clinics) to the requesting physician. Final computer results are submitted after

*University of Illinois Medical Center at Chicago*  
*Pathology Laboratories*  
*Clinical Microbiology Laboratory*

definitive identification has been completed and reviewed and signed out by the section supervisor.

- 5) All viral identifications are confirmed with monoclonal antibodies when available. Probable Enteroviruses are sent to IDPH for confirmation.
- 6) Viral isolates are stored at -70°C for future reference.

C) Virus Detection and Identification

1) Viral Cytopathogenic Effects

- a) A table describing typical viral CPE, inclusion body formation, viral hemadsorption, virus susceptibility, cell spectrum and other characteristics helpful in identification procedures is available (Table I).
- b) A pictorial atlas of typical virus CPE in stained and unstained cell cultures has been compiled for the laboratory staff as an additional aid.
- c) Representative virus cultures (formalin preserved monolayer) demonstrating viral CPE is also available for reference.

2) Immunological Methods

- a) Neutralization—Enteroviruses. Sent to the state lab per M.D.'s request.
- b) Fluorescent Antibody—CMV, HSV, VZV, Adeno group, RSV, Influenza A/B, and Parainfluenza 1, 2, 3.

**INTERPRETATION:**

The occurrence of viruses in various clinical specimens is shown in Table II. The significance of a viral isolate depends upon the nature of the illness and pathogenesis of the virus. For example: Isolation of a viral agent from the nasopharynx and stool specimens may not be related to the suspected clinical syndrome and must be interpreted with caution. However, isolation of a viral agent from the blood, CSF, and/or vesicle fluid provides direct evidence of its involvement in the disease process.

**QUALITY CONTROL:**

A) Media and Media Components



*University of Illinois Medical Center at Chicago*  
*Pathology Laboratories*  
*Clinical Microbiology Laboratory*

- 1) Only reagents quality control tested by suppliers to ensure freedom from Mycoplasma, endogenous viruses, bacteria and other extraneous agents are used in isolation procedures. Sufficient quantities of the same lot number are kept in stock supply to ensure uniform and reproducible results.
  - 2) All new lots of media are labeled with receipt date and used within their specified expiration time.
- B) Cell culture Substrates
- 1) Primary cell cultures (PRMK) and continuous cell cultures (MRC-5, A549) are obtained from reliable commercial sources and certified to be free of mycoplasma and endemic viruses.
  - 2) The laboratory staff is trained to be aware and to recognize latent virus contaminants which may be present in “normal” cell cultures, especially primary cells of Simian origin.

**REFERENCES:**

Clark, L.M. “Viruses, Rickettsiae, Chlamydiae, and Mycoplasmas.” ASM Clinical Microbiology Handbook. Washington, D.C.: ASM Press, 1992.

Evans, Alfred S. Viral Infections of Humans: Epidemiology and Control. New Haven: Plenum Medical Book co., 1991.

Winn, W. et al. Koneman’s Color Atlas and Textbook of Diagnostic Microbiology, 6<sup>th</sup> edition. Philadelphia: J.B. Lippincott Co., 2006.

Murray, Patrick R. Manual of Clinical Microbiology, 9<sup>th</sup> ed. Washington D.C.: ASM Press, 2007.

# **CHEERS QAPP 3**

## **Appendix 11: UIC Laboratory: Stool Viral Culture**

### **B: Specimen collection for virus isolation**

## SPECIMEN COLLECTION FOR VIRUS ISOLATION

Please use the swab provided in the kit and break it so that it fits into the tube containing the transport media. Then securely fasten the cap to prevent unwanted media leakage. Be sure to specify the source of the specimen on the requisition before sending it to the lab.

### Routine and HSV Isolation

Throat swabs:

Rub the tonsils and posterior nasal passages.

Throat wash:

Have patient gargle several times with 5-10ml saline.  
Collect in sterile container, transfer to transport tube.

Nasopharyngeal swabs:

Use small wire swab, insert gently into nose and down into pharyngeal area.

Nasopharyngeal wash:

Using 5-10ml saline in syringe with plastic tubing attached or bulb syringe, expel and withdraw several times.  
Transfer to transfer tube.

Sputum/Bronchial wash/

Tracheal Aspirate:

Collect in sterile container and transfer approx. 2ml to transport tube.

Eye:

Rub conjunctiva and any visible exudate.

Lesion or open vesicle:

Rub lesion or absorb vesicle fluid with swab.

Rectal swabs:

**(nonrotavirus testing)**

Insert swab 2-3cm into anal canal and rotate. An adequate sample should have visible fecal material attached to swab.  
Transfer to transport tube.

Tissue:

Place tissue in transport tube.  
For autopsy specimens, separate sets of sterile instruments should be used to prevent cross contamination. Sections of each tissue should be placed in separate labeled transport tubes. **NO FIXATIVE SHOULD BE USED.**

### **Non-Routine Virus Isolation**

These types of specimens do not require viral transport media. Send as instructed with requisition.

Urine: Collect 10-20ml sterile screw cap jar.

Feces: Collect in sterile container approx. 5grams in screw cap jar or container with tight lid.

CSF/Pericardial  
or other sterile body fluid: Collect at least 2ml in sterile tube.

### **Direct Detection**

Rsv EIA: Nasopharyngeal wash or swab are specimens of choice and may be sent in viral transport medium.

Rotavirus EIA: Feces in the specimen of choice. 1 gram or 1ml of stool is required.

**Note: ALL SPECIMENS SHOULD BE PROCESSED IMMEDIATELY. IF THERE IS A DELAY IN TRANSPORT OR SPECIMEN AFTER NORMAL LABORATORY HOURS, STORE AT 4°C.**

# **CHEERS QAPP 3**

## **Appendix 11: UIC Laboratory: Stool Viral Culture**

**C: CPE produced by viruses in monolayer cell  
cultures**

**Table 1.** Description of CPE produced by viruses in monolayer cell cultures

<b>Virus</b>	<b>Characteristic CPE</b>	<b>Development<sup>a</sup> (days)</b>	<b>Progression</b>	<b>Comments</b>
Adenovirus	Enlarged, rounded cells in tightly associated grapelike clusters. Some isolates may produce lattice-type arrangement of rounded cells.	4 - 7	Moderate	CPE is less characteristic in diploid fibroblasts and may initially resemble that of CMV.
Enterovirus	Rounded highly refractile cells in loose clusters or dispersed throughout monolayer	2 - 5	Moderate to rapid, depending on virus	CPE is similar for most enteroviruses (coxsackie A and B, echoviruses, polio, and enteroviruses 68 to 71).
Herpes viruses CMV	Plump, rounded cells in elongated foci parallel to long axis of host cells	5 - 10	Slow	Some isolates may not progress beyond a few patches of CPE, while high-titered urine specimens may yield extensive CPE within 24 h.
Herpes simplex	Clusters of rounded, ballooned cells with or without syncytia. Early CPE is focal but progresses throughout monolayer.	1 - 3	Moderate to rapid	CPE may develop more slowly and be less characteristic in human fibroblasts. Simian B virus produces similar CPE in simian cells, including primary rhesus kidney.
VZV	Foci of enlarged, rounded, refractile cells with or without syncytia. Cytoplasmic strands between infected cells and granularity may be prominent as CPE progresses.	4 - 7	Slow to moderate	
Orthomyxoviruses Influenza A and B	Variable. No CPE may be produced or may include granular and vacuolated appearance or nonspecific degeneration. Rounded refractile cells are more frequently associated with type B.	3 - 5	Moderate	HAd is independent of presence or degree of CPE
Orthopoxviruses Vaccinia	Syncytia and clusters of rounded, enlarged, refractile cells with cytoplasmic strands bridging foci of CPE	1 - 3	Moderate to rapid	Infected cells hemadsorb chicken RBCs.
Paramyxoviruses Parainfluenza, mumps, Newcastle disease	Variable, with increased rounding, granularity, and progressive degeneration. Syncytia are associated with mumps and parainfluenza type 2 and 3 viruses.	3 - 7	Moderate	HAd is independent of presence or degree of CPE
Measles (rubeola)	Syncytia appear as large multinucleated refractile areas. Nuclei may encircle granular mass of giant cell. Extensive vacuolization may also be present.	7 - 14	Slow to moderate	Infected cells may hemadsorb simian RBCs.
Respiratory syncytial	Syncytia appear as large multinucleated refractile areas.	3 - 5	Moderate	CPE in human fibroblasts is less characteristic and may resemble nonspecific cellular degeneration.
Reoviruses	Noncharacteristic granular appearance with progressive degeneration and detaching of monolayer	7 - 10	Slow to moderate	CPE may be difficult to distinguish from nonspecific degeneration of monolayer.
Rhinoviruses	Enteroviruslike	5 - 7	Moderate	

# **CHEERS QAPP 3**

## **Appendix 12: UIH Laboratory Protocol: *Cryptosporidium/Giardia***

## **MERIDIAN CRYPTOSPORIDIUM/GIARDIA DIRECT IMMUNOFLUORESCENT DETECTION**

### **INTRODUCTION:**

Protozoans of the genus Cryptosporidium are encountered worldwide and produce a self limiting gastroenteritis in immunocompetent individuals. The primary symptoms include explosive, watery diarrhea, accompanied by vomiting, abdominal cramping and low grade fever lasting two to fourteen days. In immunocompromised patients, symptoms are more severe and persistent and may result in mortality particularly in patients with Acquired Immune Deficiency Syndrome. Attempts to find effective chemotherapeutic agents have been unsuccessful thus far.

Giardia lamblia is the etiologic agent of giardiasis, an important worldwide intestinal disease. Infections in the United States were initially reported from hikers, campers and fishermen who drank stream water. The incidence of giardiasis has steadily increased over the last two decades and has become an urban parasite. There has been an increase in the prevalence of giardiasis children in day care centers, institutionalized individuals and the homosexual population. In symptomatic cases there may be irritation of the mucosal lining, dehydration, epigastric pain, flatulence, diarrhea with increased fat and mucus and anorexia lasting from several weeks to several months.

An association between Cryptosporidium and Giardia infection has not been demonstrated. However, numerous incidents of coinfection with both organisms has been documented. The immunofluorescent technique is simple to perform and has been demonstrated to have a higher sensitivity than traditional staining procedures.

### **PRINCIPLE:**

The Meridian Cryptosporidium/Giardia test utilizes the principle of direct immunofluorescence. The Detection Reagent contains a mixture of FITC labeled monoclonal antibodies directed against cell wall antigens of Cryptosporidium oocysts and Giardia cysts. A prepared fecal specimen is treated with the Detection Reagent a counterstain. The monoclonal antibodies attach to Cryptosporidium or Giardia antigens present in the specimen. The slides are rinsed to remove unbound antibodies. A coverslip is affixed with mounting medium and the slides are examined for apple green color and characteristic morphology of Cryptosporidium oocysts and Giardia cysts using a fluorescent microscope. Background material in the specimen is counterstained dull yellow to red.

### **SPECIMEN REQUIREMENTS:**

Formalinized preserved stool that has been concentrated by the formalin – ethyl acetate method.



*University of Illinois Medical Center at Chicago  
Pathology Laboratories  
Clinical Microbiology Laboratory*

**MATERIALS:**

Detection Reagent:	FITC labeled anti- <u>Cryptosporidium</u> and anti- <u>Giardia</u> monoclonal antibodies in a buffered solution containing a protein stabilizer and 0.1% sodium azide
Counterstain:	Eriochrome Black solution
20X Wash Buffer:	Concentrated wash buffer with a preservative
Positive Control-	Formalinized stool preparation of <u>Cryptosporidium</u> oocysts and <u>Giardia</u> cysts
Mounting Medium:	Buffered glycerol containing formalin, an anitquencher and 0.1% sodium azide

Transfer Loops  
Treated Slides  
Distilled or deionized water  
Wash bottle  
Humidity chamber  
Microscope coverslips 22 x 50 mm  
Applicator sticks

**EQUIPMENT:**

Fluorescent microscope

**PROCEDURE:**

A. Specimen Preparation

1. To increase the probability of detection in stools with low numbers of cysts or oocysts, the specimen should be concentrated by the formalin – ethyl acetate procedure prior to processing. (Refer to procedure manual)
2. The removal of fecal lipids by ethyl acetate may be particularly beneficial if the fecal specimen is mucoid. Delipidation will facilitate the adherence of fecal material to the treated microscope slide.
3. Allow the slide to air dry completely at room temperature (usually requires 15-30 minutes).
4. Place one drop of Detection Reagent in each well.

*University of Illinois Medical Center at Chicago*  
*Pathology Laboratories*  
*Clinical Microbiology Laboratory*

5. Place one drop of Counterstain in each well.
6. Mix the reagents with an applicator stick and spread over the entire well. Do not scratch the treated surface of the slide.
7. Incubate the slide in a humidified chamber for 30 minutes at room temperature.
8. Use a wash bottle to rinse the slide with a gentle stream of 1X Wash Buffer until excess Detection Reagent and Counterstain is removed. **DO NOT SUBMERGE THE SLIDE DURING RINSING.** Avoid disturbing the specimen or causing cross contamination of the specimens.
9. Remove excess buffer by tapping the long edge of the slide on a clean paper towel. **DO NOT ALLOW THE SLIDE TO DRY.**
10. Add one drop of Mounting Medium to each well and apply a coverslip.
11. Scan each well thoroughly using 100 – 200X magnification. The presence of Cryptosporidium oocysts should be confirmed at higher magnification.

**INTERPRETATION:**

A. Control Reactions

1. Cryptosporidium oocysts are round to slightly oval in shape, 2 – 6 microns in diameter. The oocyst wall will stain bright apple green. A suture line may also be visible.
2. Giardia cysts are oval shaped organisms 8 -12 microns long. The cyst wall will stain bright apple green.
3. Background material should counterstain dull yellow to red.

B. Test Reactions

1. Cryptosporidium positive test result: Any stool specimen exhibiting one or more oocysts with an apple green color and characteristic morphology should be considered positive for the presence of Cryptosporidium sp...
2. Giardia positive test result: Any stool specimen exhibiting one or more cysts with an apple green color and characteristic morphology should be considered positive for the presence of Giardia.

*University of Illinois Medical Center at Chicago  
Pathology Laboratories  
Clinical Microbiology Laboratory*

3. Negative test result: A stool specimen with no apple green fluorescence should be considered negative for the presence of Cryptosporidium oocysts and Giardia cysts. Background fluorescence debris which does not exhibit vibrant apple green color or characteristic morphology should also be considered negative.

**NOTES:**

1. Protect the Detection Reagent and Counterstain from exposure to light.
2. Patient specimens may contain HIV or other infectious agents and should be handled by properly trained personnel and disposed of as potential biohazards. Follow universal precautions and utilized appropriate barrier protection.
3. Specimens preserved in PVA or MF/MIF are not suitable for use with this assay. Formalin and SAF preserved specimens may be used.
4. If stool material is not seen upon scanning the slide wells, loss of sample may have occurred. This is usually due to an overly vigorous wash procedure or insufficient specimen drying time.

**QUALITY CONTROL:**

1. A Positive and negative control should be evaluated each time patient specimens are tested.
2. At the time of each use, the kit components should be visually examined for obvious signs of contamination, freezing or leakage.
3. The results of each quality control check must be recorded on the appropriate log.  
**Do Not Report Patient Results if QC Fails.**

**REFERENCES**

Fayer, R., and B. L. Ungar, 1986. *Cryptosporidium* spp. and Cryptosporidiosis. *Microbiol. Rev.* 50:458-483.

MERIFLUOR Crptosporidium/Giardia Direct Immunofluorescent Detection Procedure, Package Insert, 1991, Meridain Diagnostics, Inc. Cincinnati, OH 45244.

*Clinical Microbiology Procedures Handbook*, American Society for Microbiology, Washington, D. C., 1992.

***University of Illinois Medical Center at Chicago  
Pathology Laboratories  
Clinical Microbiology Laboratory***

Garcia, L.S., D.A. Bruckner, *Diagnostic Medical Parasitology 4<sup>th</sup> edition*,  
American Society for Microbiology, Washington, D. C., 2001.

# **CHEERS QAPP 3**

## **Appendix 13: UIH Laboratory Protocol: Rotavirus**

**MERIDIAN IMMUNO-CARD STAT ROTAVIRUS EIA**

**INTENDED USE:**

The *ImmunoCard STAT! Rotavirus* immunoassay is a rapid *in vitro* qualitative procedure for the detection of rotavirus antigen in human stool. The test can be used to aid in the diagnosis of rotavirus associated gastroenteritis.

**PRINCIPLE:**

Rotavirus is a major cause of acute gastroenteritis, especially in children 6 to 24 months in age. In addition, rotavirus infections can produce severe illness as well as asymptomatic infection in adults. The incubation period of rotavirus infection is usually one to three days, followed by gastroenteritis with an average duration of five to eight days. Virus titers in stool reach a maximum shortly after the onset of illness, then decline.

Due to inadequacies in existing culture methods, human rotavirus infection is not routinely isolated from rotavirus-containing specimens. For many years, electron microscopy has been the standard method for rotavirus detection. However, newly introduced enzyme immunoassays and latex agglutination assays with increased sensitivities and specificities are now the methods of choice. The *ImmunoCard STAT! Rotavirus* test offers a simple, rapid method for detecting rotavirus antigen in patient stool.

The **Meridian *ImmunoCard Stat! Rotavirus*** assay detects the presence of rotavirus antigen in stool. Patient specimen is diluted in Sample Diluent and then added to the sample port of the device. The sample mobilizes gold particles coated with monoclonal antibody to rotavirus and migrates along the membrane through the **Test** (polyclonal anti-rotavirus antibody) and **Control** zones. After ten minutes, the **Test** and **Control** zones are observed for the presence of red/purple line in the **Test** zone. No red/purple line in the **Test** zone indicates a negative result. The **Control** line serves as a procedural control to assure that the sample has migrated the appropriate distance along the membrane.

**SPECIMEN:**

For the best results, specimens should be collected after onset of symptoms. Several authors have reported declining numbers of rotavirus particles after day eight or nine, with peak counts occurring on days three through five. Samples collected after day eight or nine may be less reactive than those collected earlier in the course of the disease. Specimens containing high levels of blood may fail to flow in the *ImmunoCard STAT! Rotavirus* device, resulting in an invalid test result. Testing of an additional specimen is recommended under such circumstances.

Stool specimens must be collected into a clean, dry container free of detergent residue. One gram of stool (about the size of a pea) or one mL of liquid stool is required for test. **Swabs are**

*University of Illinois Medical Center at Chicago*  
*Pathology Laboratories*  
*Clinical Microbiology Laboratory*

**not acceptable.** Any request for Rotavirus collected on a swab is to be canceled and called to the floor or clinic.

**Handling Conditions:** The specimen should be tested as soon as possible, but may be stored up to 72 hours at 2 – 8°C prior to testing. If the test cannot be performed within this time frame, the specimen should be frozen at -20°C or lower.

**EQUIPMENT AND MATERIALS:**

**Materials Provided:**

**ImmunoCard STAT! Rotavirus** device  
Positive Control-Inactivated rotavirus (SA-11) in a buffer containing 0.02% thimerosal  
Sample Diluent-Buffer containing 0.1% sodium azide as a preservative  
  
Transfer pipets

**Materials Not Provided:**

12x75 mm test tubes  
Applicator sticks  
Timer

**Preparation:**

Allow kit components to reach 21 – 25°C prior to use.  
Gently mix liquid reagents prior to use.

**PRECAUTIONS:**

1. All reagents are for *in vitro* diagnostic use only.
2. All reagent concentration, incubation times and temperatures (21 – 25°C) have been optimized for sensitivity and specificity. Best results are obtained by adhering to these specifications. Once the assay has been started, complete all subsequent steps without interruption.
3. Patient specimens and used **ImmunoCard STAT! Rotavirus** devices may contain infectious agents and should be handled at Biosafety Level 2 as recommended in the CDC/NIH manual “Biosafety in Microbiology and Biomedical laboratories” 1988.

*University of Illinois Medical Center at Chicago*  
*Pathology Laboratories*  
*Clinical Microbiology Laboratory*

4. Positive Control reagent contains inactivated rotavirus. However, it should be handled as potential biohazard.
5. All reagents should be gently mixed and at 21 – 25°C before use.
6. Do not interchange reagents from different kit lot numbers, or use expired reagents.
7. Hold Positive Control vial vertically to insure proper drop size and delivery. Do not allow the tips of the vial or pipet to touch the sample port.
8. Use only one transfer pipet per control or specimen. Discard after use.
9. Stool must be mixed thoroughly (regardless of consistency) to insure a representative sample prior to pipetting. Do not use stools that have dried out.
10. Dilution of stool as described in the **PROCEDURE** section is important. Over-inoculation of stool into the Sample Diluent may restrict movement within the **ImmunoCard STAT! Rotavirus** device so as to produce an invalid result.

**QUALITY CONTROL:**

The Positive and Negative Controls should be assayed along with patients and performed each day test is performed. Patient tests are invalid if controls do not perform to specifications.

1. Add three drops of Positive control directly to **Sample** Port of appropriate device (do not dilute Positive Control).
2. Using a transfer pipet, add 150 µL Sample Diluent (Negative Control) directly to **Sample** port of appropriate device.

**Interpretation of Control Results:**

1. The Positive Control should yield a visually detectable red/purple **Test** and **Control** lines.
2. The Negative control should yield a visually detectable red/purple **Control** line. No **Test** line should be present.

**STORAGE REQUIREMENTS:**

All components must be at 21 – 25°C prior to use.



*University of Illinois Medical Center at Chicago*  
*Pathology Laboratories*  
*Clinical Microbiology Laboratory*

**PROCEDURE - STEPWISE:**

1. Sample dilution

- a. Add 350  $\mu$ L Sample Diluent to one 12x75 mm test tube for each specimen to be tested.
- b. Mix stool thoroughly, regardless of consistency.
- c. Liquid or semi-solid stool: Using a transfer pipet, draw stool to the 25  $\mu$ L calibration point (first mark from tip of pipet). Dispense the stool into the Sample Diluent in appropriate 12.75 mm tube. Using the same pipet, gently withdraw and expel the stool suspension several times, then vortex ten seconds. Leave transfer pipet in tube for further use. Note: Do not pipet more than 25  $\mu$ L of stool. Over-inoculation with stool may produce invalid results. Proceed to Step 2 within 30 minutes.
- d. Solid stool: using a wooden applicator stick, transfer a 2 mm diameter portion of stool into the Sample Diluent in the appropriate 12.75 mm tube. Emulsify the stool thoroughly using the applicator stick, then vortex ten seconds. Place transfer pipet in the tube. Proceed to Step 2 within 30 minutes.

2. Remove appropriate number of ***ImmunoCard STAT! Rotavirus*** devices from their pouches. Label appropriately. Use one device per control or sample.

3. Vortex each diluted specimen for ten seconds. Using the original specimen transfer pipet, draw diluted sample to the 150  $\mu$ L calibration point (second mark from the tip of the pipet) and add to **Sample** port.

4. Incubate ten minutes at 21 – 25°C. Note: During the ten minute incubation, diluted specimen must move past the **Control** zone.

5. Visually read **Control** and **Test** zones for the presence of absence of a red/purple line at the end of the incubation period.

**INTERPRETATION OF RESULTS:**

**Positive Test Result:** Visually detectable red/purple **Test** and **Control** lines. A positive result indicates the presence of rotavirus antigen.

**Negative Test Result:** Visually detectable red/purple **Control** line. No red/purple **Test** line present. A negative result indicates that rotavirus antigen is absent or below the level of detection.

**Invalid Test Result:** No visually detectable red/purple **Control** line, with or without a visually detectable red/purple **Test** line. An invalid test result may be due to a Reagent/Device problem,

**University of Illinois Medical Center at Chicago**  
**Pathology Laboratories**  
**Clinical Microbiology Laboratory**

a procedural error, or over-inoculation of stool into Sample Diluent during specimen dilution. Re-dilute stool and repeat test. Stools containing high levels of blood may fail to flow properly, resulting in an invalid result. Testing with an additional specimen is recommended. On occasion, a stool may have very high levels of rotavirus antigen and will yield a visible **Test** line and no visible **Control** line. In such cases, the specimen may be diluted two-fold or greater, beyond original 1:15 dilution (ex. 25 µL stool + 750 µL Sample Diluent) and retested.

**REPORTING RESULTS:**

**Positive Test Result:** All positive test results must be called to the floor or clinic. Under the function MEH enter the code PROTA with the name, date, and time of the person notified of the result.

**Negative Test Result:** Under the function MEH enter the code NROTA.

**Invalid Test Result:** Under the function MEH enter the code IND and free text the comment “please recollect sample”.

**LIMITATIONS OF THE PROCEDURE:**

1. The **ImmunoCard STAT! Rotavirus** test does not define the presence of rotavirus associated gastroenteritis, but only demonstrates the presence of the antigen in stool. As with all *in vitro* diagnostic procedures, test results should be interpreted by a physician in conjunction with other clinical information.
2. Limit of detection in stool specimens is  $1.8 - 3.7 \times 10^6$  rotavirus particles per test volume.
3. The use of meconium stools in this assay is not recommended as their performance characteristics have not been evaluated.
4. A positive result does not preclude the presence of other infectious organisms.

**REFERENCES:**

**Meridian ImmunoCard Stat! Rotavirus** package insert 12/01. Meridian Diagnostics, Inc., Cincinnati, OH.

Winn, W. et al., Koneman's Color Atlas of Diagnostic Microbiology, 6<sup>th</sup> Ed., Philadelphia, PA Lippincott, 2006.

# **CHEERS QAPP 3**

## **Appendix 14: UIH Laboratory Protocol: Eye Cultures**

## **EYE CULTURES**

### **PRINCIPLE:**

Inflammatory eye conditions may be due to a variety of diseases, and microorganisms play a major role in both acute and chronic eye diseases. The detection of infectious agents depends on the knowledge of the site of infection and the severity of the process, because a variety of organisms cause infections of the eye. Unlike the procedures with other specimen types, it may be important for the physician to inoculate culture media at the bedside rather than transport the specimen to the laboratory for processing.

This procedure describes the clinical syndromes associated with bacterial infections of the eye, the organisms associated with these syndromes, and the procedure for isolation of these infections.

### **MICROORGANISMS ENCOUNTERED IN EYE INFECTIONS**

#### **A. Conjunctivitis**

##### **1. Description of syndrome**

Conjunctivitis is an acute or chronic inflammation of the conjunctiva, the mucous membrane covering of the anterior surface (sclera) of the eye. The symptoms include reddening of the surface, tearing, and a purulent discharge. The source of the involved bacterial organism is usually direct inoculation of exogenous organisms from fomites, and the environment, etc, but hematogenous spread from another focus can occur.

##### **2. Common causes of infection**

- a. *Haemophilus influenzae*
- b. *Staphylococcus aureus*
- c. *Streptococcus pneumoniae*
- d. *Neisseria gonorrhoeae*

##### **3. Causes of infections in immunocompromised patients**

- a. Members of the family *Enterobacteriaceae*
- b. *Pseudomonas aeruginosa*

#### **B. Bacterial keratitis**

##### **1. Description of the syndrome**

Keratitis is defined as an inflammation of the cornea. It may present with a wide range of symptoms extending from a superficial infection of the corneal epithelium to deep stromal ulceration that may lead to perforation and/or loss of the eye. It is a

**University of Illinois Medical Center at Chicago**  
**Pathology Laboratories**  
**Clinical Microbiology Laboratory**

serious condition requiring prompt and meticulous investigation. Predisposing factors for corneal ulceration include prior eye disease, contact lens wear, and use of topical corticosteroids. Other individuals at risk include alcoholics, burn patient and other immunocompromised patient.

Symptoms of keratitis include redness of the eye, inflammation of the conjunctiva, increased pain, decreased vision, and photophobia. Patients feel a foreign-body sensation in the eye that results in tearing and exudate formation.

2. Common causes of infection
  - a. *Pseudomonas aeruginosa* (often progresses rapidly and may result in corneal perforation in a few hours)
  - b. *Streptococcus pneumoniae*
  - c. *Moraxella sp.*
  - d. Alpha hemolytic streptococci
  - e. *Staphylococcus aureus*
  - f. Coagulase negative staphylococci
3. Less common bacterial causes of infection
  - a. *Enterobacteriaceae*
  - b. *Neisseria gonorrhoeae*
  - c. *Neisseria meningitidis*
  - d. *Haemophilus influenzae*
  - e. Rapidly growing mycobacteria
  - f. *Actinomyces sp.*
  - g. *Propionibacterium acnes*
  - h. *Clostridium perfringens*
4. Contact lens associated causes of infection
  - a. *Bacillus sp.*
  - b. *Serratia sp.*

C. Bacterial endophthalmitis

1. Description of the syndrome

Endophthalmitis is the most serious and sight-threatening infection of the eye. It is an inflammation of the ocular cavities and intraocular tissue resulting from trauma to the eye, including surgery, injury, or corneal suppuration and perforation following keratitis. Endogenous endophthalmitis as a result of bacterial sepsis or from a contagious site, ie., cellulitis, may also occur. The infection following surgery will often manifest within 72 hours of surgery, presenting with decreased vision, pain, lid edema, conjunctival hyperemia, severe iridocyclitis, and hypopyon. Chronic endophthalmitis may follow.

**University of Illinois Medical Center at Chicago**  
**Pathology Laboratories**  
**Clinical Microbiology Laboratory**

2. Common causes of infection
  - a. Postsurgical endophthalmitis
    - 1) *Staphylococcus aureus*
    - 2) Coagulase negative staphylococcus
    - 3) *Streptococcus pneumoniae*
    - 4) *Streptococcus sp.*
    - 5) *Pseudomonas aeruginosa*
    - 6) Other gram-negative bacilli
  - b. Postcataract surgery (chronic, occurring months to years after surgery)
    - 1) *Propionibacterium acnes*
  - c. Posttraumatic endophthalmitis
    - 1) *Bacillus cereus*
    - 2) *Bacillus licheniformis*
    - 3) *Bacillus subtilis*
    - 4) *Clostridium sp.*
  - d. Endogenous endophthalmitis
    - 1) *Staphylococcus aureus*
    - 2) *Streptococcus pneumoniae*
    - 3) *Haemophilus influenzae*
    - 4) *Neisseria meningitidis*
    - 5) *Bacillus sp.*
    - 6) *Mycobacterium sp.* (rapid growers)

D. Preseptal cellulitis

1. Description of the syndrome

Preseptal cellulitis is an inflammation of the periorbital tissue resulting from traumatic injury, laceration, or a puncture wound. It may also result from an extension of impetigo or erysipelas. Symptoms are a warm erythematous eyelid with conjunctival edema. The condition needs to be differentiated from orbital cellulitis, a more-systemic, severe infection of the orbit itself.

2. Common causes of infection

- a. *Staphylococcus aureus*
- b. *Streptococcus pyogenes*
- c. other streptococci
- d. *Haemophilus influenzae*

**University of Illinois Medical Center at Chicago**  
**Pathology Laboratories**  
**Clinical Microbiology Laboratory**

3. Traumatic injury with foreign body contamination
  - a. *Clostridium sp.* may be involved alone or mixed with aerobes
4. Uncommon causes of infection
  - a. *Pseudomonas sp.*
  - b. Other gram-negative bacilli

E. Orbital cellulitis

1. Description of the syndrome

Orbital cellulitis is an infection of the orbital tissue resulting from trauma, surgery, or an extension of paranasal infection or panophthalmitis. It is a serious, systemic infection and may cause blindness, septic thrombosis of the cavernous sinus, or intracranial infections. Symptoms include fever, leukocytosis, lid edema, and limitation of ocular motility.

2. Common causes of infection

- a. Postsurgical infection
  1. *Staphylococcus aureus*
- b. Trauma
  1. Mixed anaerobic and aerobic infections may occur.
- c. Extension from panophthalmitis
  1. *Staphylococcus aureus*
  2. *Streptococcus pneumoniae*
  3. *Pseudomonas aeruginosa*
- d. Extension of a paranasal infection
  1. *Haemophilus influenzae* (especially in children less than 5 years old)
  2. *Staphylococcus aureus*
  3. *Streptococcus pyogenes*
  4. *Streptococcus pneumoniae*
  5. Gram-negative bacilli

F. Miscellaneous eye infections

1. Dacryoadenitis
  - a. Description of the syndrome

**University of Illinois Medical Center at Chicago**  
**Pathology Laboratories**  
**Clinical Microbiology Laboratory**

Dacryoadenitis is an infection of the lacrimal glands. Symptoms include pain and tenderness in the upper lid.

- b. Common causes of infection
  - 1. *Staphylococcus aureus*
  - 2. *Streptococcus pyogenes*
  - 3. *Streptococcus pneumoniae*

2. Dacryocystitis

- a. Description of the syndrome

Dacryocystitis is an infection of the lacrimal sac that usually follow obstruction of the nasolacrimal duct. Symptoms include pain, swelling, redness, and tenderness of the lacrimal gland. A fistula may form.

- b. Common cause of infection
  - 1. *Streptococcus pneumoniae*
  - 2. *Staphylococcus aureus*
  - 3. *Streptococcus pyogenes*
  - 4. *Haemophilus influenzae*

3. Canaliculitis

- a. Description of the syndrome

Canaliculitis is an inflammation of the canaliculus, the passage that connects the punctum to the lacrimal sac. Symptoms include swelling, pain, and tenderness at the corner of the eye. The infection may be accompanied by unilateral conjunctivitis and hyperemia of the eyelid.

- b. Common causes of infection
  - 1. *Actinomyces israelii*
  - 2. *Propionibacterium propionicus*
  - 3. *Moraxella sp.*
  - 4. Diphtheroids
  - 5. Alpha hemolytic streptococci

**SPECIMEN:**

**Acceptable Specimens:**



**University of Illinois Medical Center at Chicago**  
**Pathology Laboratories**  
**Clinical Microbiology Laboratory**

1. Sterile tubes: Fluids can be transported in sterile vacutainer tubes without preservatives
2. Swabs
3. Cornea or lens
4. Specimen received on plates and broth

**Unacceptable Specimens:**

1. Mislabeled and unlabelled specimens
2. Dried swabs, or swabs with ampules not crushed
3. Specimens received >24 hours after collection
4. Specimens received in citrate or EDTA tubes

**Specimens Types:**

A) Fluid Specimens

- Vitreous fluid
- Anterior chamber

B) Specimens sent on swabs

- Conjunctiva
- Eye lid
- Corneal rim
- Lens
- Cornea

C) Specimens sent on plates and broth:

- Corneal scraping
- Vitreous fluid
- Anterior Chamber

**Handling Conditions:**

All specimens must be sent to the laboratory as soon as they are collected.

Once the specimen is in the laboratory, it must be processed promptly. If there is a delay in the processing, eye specimens must be placed in the CO<sub>2</sub> incubator.

The type of container the specimen came in must be entered into the computer under SREQ for each test ordered.

**EQUIPMENT AND MATERIALS:**

***University of Illinois Medical Center at Chicago  
Pathology Laboratories  
Clinical Microbiology Laboratory***

**Equipment:**

35°C CO<sub>2</sub> Incubator  
Laminar Flow Hood  
35°C ambient air incubator

**Materials:**

Chocolate Agar Plate (CHOC)  
Blood Agar Plate (BAP)  
Eugonic Broth  
Glass microscope slides (for requested Gram Stains)  
Sterile pipette  
Sterile forceps

**QUALITY CONTROL:**

Quality control on all commercially prepared culture media adheres to CLSI (NCCLS) M22-A3 standards. Refer to Protocol for QC on Media procedure.

**PROCEDURE - STEPWISE:**

A. Gram Stains

1. Gram stains are performed upon request only.
2. Reporting of Gram Stain results: refer to Gram Stain/Direct Exam Procedure

B. Culture Examination and Interpretation

1. Initial examination of plates is made 18-24 hours after specimen is processed. Preliminary reports are updated daily until report is final.
2. No growth plates are incubated for 72 hours before final report is sent out. No growth Eugonic broths are incubated for 72 before final report and held for 10 days before being discarded.
3. On cultures with growth, Chocolate plate must be incubated for 72 hours (for *Neisseria gonorrhoeae*) before being discarded. Subculture positive Eugonic broths which have no growth on original plates or no plates were received.

**University of Illinois Medical Center at Chicago**  
**Pathology Laboratories**  
**Clinical Microbiology Laboratory**

4. Report the quantity and organism identity for each morphological type observed on culture media. Conjunctive and eye lid cultures which grow few to moderate numbers of multiple organisms including Coagulase negative staphylococci, diphtheroids, alpha Strep, Gram negative rods, *Bacillus sp.*, etc. do not identify, report the relative quantity and type of organisms only, i.e. "4 colonies Staph." Hold plates on bench a few days in case physician questions report.
5. Any organisms found in corneal ulcer, vitreous fluid, other sterile site is considered significant and should be worked up with sensitivities. If these cultures are mixed with multiple organisms bring up at rounds.

C. Antimicrobial Susceptibility Testing

1. For general policy, follow Antimicrobial Susceptibility Testing Protocol.
2. If *Haemophilus influenzae* is isolated, beta lactamase testing is done.

**REPORTING RESULTS:**

1. Report the quantity and organism identity for each morphological type observed
2. The appropriate physician is informed by phone about possible *Neisseria gonorrhoeae*, *Pseudomonas aeruginosa*, any growth in vitreous fluid cultures.
3. Eye bank should be notified on any growth found in eye bank cultures.

**NOTE:** The date and name of the person the report is given to must be recorded in the **CULTURE** field of the Mysis report.

**REFERENCES:**

Isenberg, Henry D. 1992. *Clinical Microbiology Procedures Handbook*. American Society for Microbiology, Washington, D.C.

Winn, W. et al. 2006 *Koneman's Color Atlas and Textbook of Diagnostic Microbiology*, 6th ed. Lippincott-Raven, Philadelphia, PA.

# **CHEERS QAPP 3**

## **Appendix 15: UIH Laboratory Protocol: Wound Culures**

## **WOUND CULTURES**

### **PRINCIPLE:**

The accumulation of pus, either within an abscess or exuding from a sinus tract or from a mucocutaneous surface, is one of the indicators of local sepsis. Varying degrees of redness, pain, and swelling may also be present. Exogenous wound infections may also be present. Exogenous wound infections include those associated with traumatic injury wounds or decubitus ulcers, animal or human bites, burns, or foreign bodies in the skin or mucous membranes.

Endogenous wounds and abscesses may be associated with appendicitis, cholecystitis, cellulitis, dental infections, osteomyelitis, empyema, septic arthritis, sinusitis, or many other internal infections. Many of these infections are nosocomial, secondary to invasive procedures, surgical manipulations, or placement of prostheses. Others originate from hematogenous spread from other primary sites of infection or by direct extension of bacterial contaminants from ruptured viscera, particularly the large intestine.

*University of Illinois Medical Center at Chicago*  
*Pathology Laboratories*  
*Clinical Microbiology Laboratory*

**SPECIMEN:**

**Acceptable Specimens:**

1. Specimens received on aerobic swabs, gel swabs or anaerobic transport media.

Swabs specimens are the least desirable for culture, as the quantity of the sample may not be sufficient to ensure adequate recovery of the infectious agent.

2. Stool or rectal swabs sent to rule out VRE.

3. Any source that is not a fluid (the source dictates the order). For example,

- Pus (from any site)
- Fluid (from any site)
- Abscess drainage
- Abscess (from any site)
- Abdominal wound
- Leg wound

**Unacceptable Specimens:**

1. Mislabeled or unlabeled specimens.
2. Specimens received >24 hours after collection.
3. Specimens received without appropriate source documentation.
4. Specimens received on dried swabs, or swabs with ampules not crushed.
5. Specimens received on expired BBL plus swabs/anaerobic transport media.

**Type:**

Surface wounds are more often than not colonized with environmental bacteria, and swab samples often do not reflect the true cause of the infectious process. Aspiration of fluid or pus from the depths of pustular or vesicular wounds and abscesses with a sterile needle and syringe is the most desirable method for collecting material for culture. Ideally, a biopsy specimen of the leading edge of the wound is the best specimen for culture. The site from which the culture is to be obtained should first be decontaminated with surgical soap and 70% ethyl or isopropyl alcohol.

*University of Illinois Medical Center at Chicago*  
*Pathology Laboratories*  
*Clinical Microbiology Laboratory*

**Handling Conditions:**

All specimens must be sent to the laboratory as soon as they are collected.

Once the specimen is in the microbiology laboratory, it must be processed promptly. If there is a delay in specimen processing, fluid specimens must be placed in the incubator and swab specimens must be left at room temperature.

**EQUIPMENT AND MATERIALS:**

**Equipment:**

35°C CO<sub>2</sub> incubator  
Laminar flow hood  
Heating block

**Materials:**

Chocolate agar plate (CHOC)  
Blood agar plate (BAP)  
MacConkey agar plate (MAC)  
Colisitin-Naladixic acid agar plate (CNA)\*  
Modified Thayer-Martin agar plate (MTM)\*\*  
Sterile loops  
Glass Microscope slide  
Gram stain slip\*\*\*

\* CNA agar is the only media used if the source of the specimen is rectal swab or stool and the special request is R/O VRE (vancomycin resistant enterococci). This order is usually from the Stem Cell floor (8WST). No gram stain should be prepared for this type of order.

\*\* MTM agar should only be used if the source of the specimen is in a genital region (penile, labial, perineum, rectal, groin, etc.).

\*\*\* Gram stain slip should be prepared for those wound cultures accompanied by a GRAM STAIN ONLY order. Please note the site of the wound under source on the Gram stain slip. Gram stains should be read before the end of the shift, unless it is ordered STAT then it should be read within 1 hour.

**QUALITY CONTROL:**

*University of Illinois Medical Center at Chicago*  
*Pathology Laboratories*  
*Clinical Microbiology Laboratory*

Quality control on all commercially prepared culture media adheres to CLSI (formerly NCCLS) M22-A2 Standards. Refer to Protocol for QC on Media procedure.

**PROCEDURE - STEPWISE:**

**For the fluid specimen:**

1. Label specimen, plates, and a glass slide with patient's name and accession number (use the SunQuest labels).

**\*NOTE: All of the following steps must be performed inside a laminar flow hood.**

2. Mix specimen very well before inoculating plates. Aspirate approximately 1 ml of specimen using a sterile transfer pipette. Inoculate media by dropping 1 to 2 drops of the specimen onto each plate.
3. Place one drop of the specimen on a glass slide for a Gram stain (Do not touch slide with the pipette). If no Gram stain was ordered, label the slide WDCT and place slide on heating block to dry. If a Gram stain was ordered, label a Gram stain slip with a GRAM STAIN ONLY label and place slide on heating block to dry.
4. Using a sterile loop, streak each plate to obtain well isolated colonies. Make sure to use a different loop for each plate.
5. Make a few small stab marks with the loop into the surface of the BAP for demonstration of subsurface hemolysis.
6. Incubate plates in the CO<sub>2</sub> incubator.

**For the swab specimen:**

1. If the specimen is received on a double swab or Port-a-Cul transport system, roll one swab over a small area at the edge of each plate.
2. Take the second swab and roll it over a small area on the glass slide for Gram stain, and discard swab. If no Gram stain was ordered, label the slide WDCT and place slide on heating block to dry. If a Gram stain was ordered, label a Gram stain slip with a GRAM STAIN ONLY label and place slide on heating block to dry.
3. Using a sterile loop, streak each plate to obtain well isolated colonies. Make sure to use a different loop for each plate.



***University of Illinois Medical Center at Chicago  
Pathology Laboratories  
Clinical Microbiology Laboratory***

4. Make a few small stab marks with the loop into the surface of the BAP for demonstration of subsurface hemolysis.
5. Incubate plates in the CO<sub>2</sub> incubator.

***If the specimen is received in an anaerobic transport system and both an aerobic and anaerobic culture is ordered it will be necessary to use both the swabs carefully. Use one swab to setup plates for the cultures and the second swab to setup the two Gram stains necessary for both cultures (refer to Anaerobic Specimen Processing procedure for further instructions on processing the anaerobic cultures).***

# **CHEERS QAPP 3**

## **Appendix 16: IDPH Laboratory Protocol: Shigatoxin**

STANDARD OPERATING PROCEDURE  
Illinois Department of Public Health – Division of Laboratories

Section: Molecular Laboratory, Divison-Wide	
Title: Detection of Shiga Toxin-Producing O157:H7 <i>Escherichia coli</i> by Real-Time Polymerase Chain Reaction (PCR)	Effective Date: Upon Approval
Author: John F. Nawrocki, Ph.D.	Revision No. 1
	Reason for Revision: Division

**Test Name**

Detection of Shiga Toxin-Producing O157:H7 *Escherichia coli* by Real-Time Polymerase Chain Reaction (PCR)

**Table of Contents**

1.	Principle .....	2
2.	Requirements for Specimen Collection and Handling .....	3
3.	Quality Control Statement .....	3
4.	Safety .....	5
5.	Overview of the Test .....	5
6.	Reagents, Standards, and Controls .....	5
7.	Instrumentation .....	6
8.	Step-by-Step Directions .....	6
9.	Specific Quality Control Material to Use .....	13
10.	Procedure Note .....	13
11.	Expected Values (Normal range) .....	13
12.	Interpretation of the Data .....	13
13.	Reporting Method .....	14
14.	Method Limitation .....	15
15.	Contingency Plans .....	15

16.	References .....	15
17.	Appendix .....	17
18.	Approval .....	32

1. **Principle**

- 1.1 Shiga-toxin producing *Escherichia coli* (STEC) are a major cause of food-borne disease worldwide, and are responsible for disease and infection associated with extreme diarrhea (watery and bloody), hemolytic uremic syndrome (HUS), cytotoxicity, neurotoxicity, enterotoxicity with fluid accumulation, coagulation abnormalities, and death (16.1; 16.8; 16.9; 16.12). The main sources of STEC infection are uncooked ground beef, raw contaminated vegetables, and contaminated water (16.1). STEC bacteria may also be spread from person to person in such settings as nursing homes and daycare centers, and the highest rates of STEC infection are in children under 5 and among the elderly (16.1). Although antibiotics are available that can be used to treat STEC infections they are not recommended for treatment because they can increase the likelihood of HUS (16.6).
- 1.2 There are over 250 serotypes of STEC that produce the Shiga toxins (16.6). By far the most prevalent pathogen is the 0157:H7/NM serotype accounting for approximately 73,000 illnesses a year (16.1; 16.10). Other serotypes, including 026H4 and 0111 H8/NM, account for 33,000 illnesses annually. Based on serological methods and DNA sequencing studies, two major subclasses of Shiga toxins have been identified (16.4): Shiga toxin 1 (Stx 1) and Shiga toxin 2 (Stx2). Stx1 is chromosomal and is relatively homogenous (16.4). Stx2 is phage-associated and there are five different subtypes including Stx2, Stx2c, Stx2d, Stx2e, and Stx2f (16.4). Each toxin has a single enzymatic A subunit and a pentameric B subunit that controls binding of the toxin to the globotriacylceramide receptor of the intestine (16.5). The A subunit of the toxin targets the 28S rRNA of the 60S ribosomal subunit and removes adenine groups. This results in inhibition of protein synthesis.
- 1.3 Due to the morbidity and mortality associated with STEC outbreaks these pathogens are a major public health problem. The ability to control diseases associated with STEC and limit outbreaks depends on the rapid detection of these pathogens (16.6). The conventional method used in most laboratories is based on sorbitol MacConkey agar culture (SMAC) coupled with the detection of the 0157 antigen (16.1;16.11). The SMAC assay, however, can not detect non-0157 serotypes that produce Shiga toxin. This is a growing concern as this group of STEC is becoming increasingly important clinically (16.1; 16.7) with the CDC estimating that one-third of STEC-associated diarrhea are caused by non-0157 STEC strains (16.10). In these cases up to 10% of victims suffer HUS, and in this group up to 5% may die and 30% experience chronic renal failure. Few laboratories test for these strains so actual prevalence is not known (16.7).
- 1.4 To reliably identify patients with STEC-associated diseases, assays are required that can directly test for the Shiga toxins or their genes. Two commercial assays test directly for the toxin. ProSpecT microplate assay (16.1), and the Premier EHEC enzyme-linked immunoassay (16.2). Both assays utilize antibodies directed against the Shiga toxins and detect non-0157 STEC

strains. Both assays, however, are difficult to perform, are time-consuming, and lack optimal sensitivity. An attractive alternative is the detection of the Shiga toxin genes by polymerase chain reaction (PCR; 16.3; 16.4; 16.5). The assay directly detects the Shiga toxin genes and thus will detect non-O157:H7 strains, is extremely rapid, and is more sensitive than either the ProSpec T or Premier assays. For these reasons our laboratory decided to adapt a real-time PCR assay developed by the CDC to detect the Shiga toxin-producing *E. coli* strains (16.6a). This assay is designed to detect and discriminate between the Stx 1 versus Stx 2 genes in *E. coli* from enriched patient stool specimens or colonies isolated on MacConkey's agar plates. In addition, we have adopted the CDC real-time PCR assay for the direct detection of the O157:H7 genotype of *E. coli* (16.6b). This manual provides instructions on how to perform this test.

## 2. Requirements for Specimen Collection and Handling

- 2.1 Stool specimens should be collected using a Cary Blair swab or Cary Blair spatula collection tubes. Cultures grown on MacConkey agar plates are also acceptable specimens. **See Appendix 4, SOP for Shipping (DOS010) for complete instructions.** Specimens must be labeled to include the full patient name, date of birth, and collection date.
- 2.2 Unacceptable specimens include those with mismatched requisitions, specimens not shipped at 4°C, and any non-stool specimens. In the last case supervisory approval is required for testing to proceed.
- 2.3 **A test requisition** that includes the test ordered, full patient name and identifiers (including sex and date of birth), source of specimen and date of collection, the submitting organization, referring physician if appropriate, and contact information must accompany specimens. Test orders received over the telephone are acceptable and the test must be run according to the latest version of the CLIA regulations issued January 24, 2003. Historically we have been required to hold the sample until a written or electronic communication of the test requisition was sent to us. The new January 24 CFR modifies this requirement and allows us additional flexibility, resulting in faster turnaround times. If a telephone request is accepted the laboratory must solicit a written or electronic authorization within 30 days of the oral request and must maintain the authorization or documentation of its efforts to obtain the authorization. This CFR was implemented on May 15, 2003 by the Division of Laboratories with the implementation of appropriate logs to document attempts to collect any missing information/test request. However, testing and reporting is not withheld due to lack of information.

## 3. Quality Control Statement

- 3.1 **Corrective Action Log:** Any deviations from the expected test performance are entered in the laboratory's standard corrective action log. These include, but are not limited to, failures of positive and negative extraction and master mix controls. The log entries must include a statement of the problem, results of investigations into the deviations observed, actions taken to correct the problem, and the outcome of these actions.
- 3.2 **Internal Extraction Control** The bacterial ribosomal 16S gene is the internal extraction control. Negative Shiga toxin and O157:H7 results are only valid if the 16S gene is amplified. Test with negative results for Shiga toxin and the 16S gene are invalid and must be repeated.

- 3.3 **Melting Curve analysis:** The melting temperature (TM) of Shiga toxin 1 must be 68°C (variants of 62°C and 65°C have been reported). The TM of Shiga toxin 2 must be 71°C (variants of 51°C, 55°C, 63°C, and 66°C have been reported). The TM for the O157:H7 genotype is 67-68 °C.
- 3.4 **Minimization and prevention of PCR contamination:** You must review procedures for the minimization and prevention of PCR contamination before you initiate work on this test. See the Appendix, section 17.6 (PCR Etiquette) for more information. Two sources of contamination are previously amplified DNA called amplicons, and DNA extracted from specimens in previous assays. Measures to prevent the contamination of your assay with either source are:
- 3.4.1 **Restricted Traffic Flow:** All transfer of reagents and supplies is restricted in the direction from area #1 (cleanest area used to prepare master mixes), to area #2 (DNA extraction) and finally to area #3 (amplification and detection of PCR products). Materials and supplies (including gloves and laboratory coats) should not be transferred from area to area in the opposite direction. All positive control materials are to be confined to area #3.
  - 3.4.2 **Use of Amperase:** Amplicons are made with a nucleotide mix containing dUTPs. As potential contaminants in subsequent PCR reactions, these amplicons are destroyed by Uracil N-glycosylase (Amperase) which is included in all PCR reactions. Barring an overwhelming contamination with amplicons, only DNA extracted from specimens will be amplified.
  - 3.4.3 **Bleaching:** All surfaces and pipettors need to be wiped with 10% bleach before and after running the assay to destroy amplicons or DNA extracted from a previous assay.
  - 3.4.4 **UV-irradiation:** All operations are carried out in a biological safety cabinet or glove box equipped with UV lights. Before and after working in the hoods, the area is UV-irradiated (2 hours) which effectively destroys contaminating DNA and amplicons.
  - 3.4.5 **Detection of Contamination** The negative extraction control tests for contaminating amplicons and/or RNA from the previous assay. If amplified Influenza is detected in this control the assay is invalid and must be repeated. All work stations are rigorously cleaned and tested for Shiga toxin contamination before the test is repeated. See Appendix section 17.7 (Wipe Test) for instructions on how to conduct this test.
- 3.5 **Equipment Maintenance:** All equipment must be inspected and maintained according to the manufacturer's recommendations (see commercial manuals 16.13-16.18). Temperatures must be checked and recorded daily for refrigerators/freezers, water baths and other incubation devices. Pipeting devices must be calibrated at least every 6 months or according to the manufacturer's recommendations (16.17 and 16.18).
- 3.6 **Reagents:** Reagent lot numbers and expiration dates must be recorded on work sheets to insure that no expired reagent is used for testing. When new reagent lot numbers are used, results are checked with the same controls (lot numbers entered on the bench work sheet) to ensure results are the same obtained with old lot numbers.

- 3.7 **Competency and Proficiency tests:** Each technician must pass a **competency** test before they can perform the assay on patient specimens. This test is administered by the laboratory supervisor and includes known positive and negative specimens. The laboratory must subscribe (CAP or otherwise) to a **proficiency** program to evaluate the test performance on a regular basis (at least twice a year).

#### 4. **Safety**

- 4.1 Each laboratory section is responsible for maintaining a current awareness file of Occupational Health and Safety Act (OSHA) regulations regarding the safe handling of the chemicals specified in this method. A reference file of Material Safety Data Sheets (MSDS) is available to all personnel involved in this analysis. Additional information on laboratory safety can be found in the Chemical Hygiene Plan and the Laboratory Safety Manual.
- 4.2 Specific to this procedure, safety and biohazard concerns are highlighted at the appropriate steps. The specific concern is indicated with procedures to protect you.

#### 5. **Overview of the Test (see the Work flow diagram in Appendix section 17.0)**

- 5.1 The Enteric laboratory identifies cultures that need to be tested and initiates a Specimen and Results Tracking form (see Appendix section 17.9) by filling out the first 4 columns (specimen number, patient name, type of specimen received in the Enteric laboratory, and type of specimen transferred to the Molecular laboratory).
- 5.2 The specimen, a copy of the requisition, and the Specimen and Results tracking form is forwarded to the Molecular laboratory.
- 5.3 A crude DNA preparation is made from a portion of the culture.
- 5.4 The presence of Shiga toxins 1 and 2 is detected using a multiplex real-time polymerase chain reaction assay.
- 5.5 The presence of the O157:H7 genotype is detected in a separate real-time polymerase chain reaction assay.
- 5.6 Confirmation that DNA was extracted from the patient specimen is confirmed by the positive amplification of the bacterial 16S ribosomal DNA in using a real-time polymerase chain reaction assay. Failure to amplify this DNA invalidates Shiga toxin and O157:H7 results for the patient specimen.
- 5.7 Results of each test is entered on the Specimen and Results Tracking form and forwarded to the Enteric laboratory.
- 5.8 The Enteric laboratory reviews the results and issues reports.

#### 6. **Reagents, standards and controls**

- 6.1 Roche LightCycler- DNA Master Hybridization Probes (Cat#12 158-825-001)
- 6.1.1 Red cap #1; 10X reaction buffer with Taq enzyme, dUTP's and 10 mM MgCl<sub>2</sub>
- 6.1.2 Blue cap #2; 25 mM MgCl<sub>2</sub>
- 6.1.3 Colorless cap #3; PCR-grade water.

- 6.2 CDC Shiga-toxin (types 1 and 2) producing, O157:H7 positive control culture EDL-933
  - 6.2.1 Viable stocks are maintained at -70°C in 50% glycerol
  - 6.2.2 A stock of liquid culture in MacConkey's media is maintained at 4°C to be used as a positive extraction control.
  - 6.2.3 EDL-933 DNA should yield a positive result in the Shiga toxin 1, Shiga toxin 2, and O157:H7 real-time PCR reactions.

## 7. Instrumentation

- 7.1 Roche LightCycler Instrument, Version 3.5 This instrument performs the polymerase chain amplification and real-time detection. The instrument performs a self-check each time it is used. Results of this self-check (pass or fail) are recorded on the bench work sheets (Appendix, 17.1) for the day's run. If the instrument fails, the specific information is recorded and the technical help support staff at Roche is contacted. If the problem persists, the instrument is sent back to Roche and they send out a loaner instrument. The instrument is cleaned monthly and the calibration program is updated every 6 months (see Appendix section 17.8 for the documentation table). Consult the manufacturer's manual for more details (16.13).

## 8. Step-by-step instructions.

- 8.1 Preparation of enriched stool specimens

- 8.1.1 Reagents

- 8.1.1.1 MacConkey broth
- 8.1.1.2 MacConkey agar plate

- 8.1.2 Supplies

- 8.1.2.1 Sterile loop
- 8.1.2.2 Test tube rack

- 8.1.3 Equipment

- 8.1.3.1 Biological Safety Cabinet
- 8.1.3.2 Bacteriological Incubator (range 34°C-37°C)

- 8.1.4 Procedure

- 8.1.4.1 Initiate a bench work sheet for the assay. This work sheet contains all information required for recording lot numbers and expiration dates of reagents, self checks for instrumentation, and a plate map for loading samples for the PCR test. Make sure that you fill out the bench sheet fully as the assay proceeds. The work sheet is included in the Appendix, section 17.1.
- 8.1.4.2 Label a MacConkey broth tube for each specimen to be tested
- 8.1.4.3 Transfer stool specimens and broth tubes to a vented biological



safety cabinet.

- 8.1.4.4 Using sterile technique, transfer a loop-full of stool into the broth.
- 8.1.4.5 Incubate the broth for at least 8 hours (overnight) in a bacteriological incubator (range 34°C-37°C).
- 8.1.4.6 Note: It is also acceptable to enrich the stool specimen by streaking on a MacConkey agar plate.

## 8.2 Preparation of DNA from enriched stool specimen or isolated colonies

### 8.2.1 Reagents

- 8.2.1.1 DNA-grade water (certified by the manufacturer to be free of DNase activity)
- 8.2.1.2 Positive control culture-EDL 933

### 8.2.2 Supplies

- 8.2.2.1 Sarstedt tubes with O-ring seal (#72.693.005)
- 8.2.2.2 Filter pipette tip
- 8.2.2.3 Biohazard bags

### 8.2.3 Equipment

- 8.2.3.1 Eppendorf microfuge
- 8.2.3.2 Biological Safety cabinet
- 8.2.3.3 Eppendorf pipettors
- 8.2.3.4 Heating block
- 8.2.3.5 Vortex mixer

### 8.2.4 Procedure

- 8.2.4.1 Label one Sarstedt tube for each patient sample, a negative control and a positive control. These tubes are equipped with an O-ring in the cap.
- 8.2.4.2 Transfer approximately 0.5-1.0 ml of the MacConkey-enriched stool specimen, positive EDL933 culture, and DNA-grade water into the patient labeled tubes, positive control and negative control tube, respectively.
- 8.2.4.3 Centrifuge tubes for 1 minute at 13,000 rpm's in the microfuge.
- 8.2.4.4 The patient and positive control tubes will have a bacterial pellet. Carefully remove the supernatant using a pipette tip and pipettor and dispense in a biohazard bag.
- 8.2.4.5 Transfer 0.5-1.0 ml of DNA-grade water into the tubes and make sure that the tube is tightly sealed with the O-ring cap. Re-suspend the bacterial pellets by vortexing.

- 8.2.4.6 To prepare DNA from an isolated colony, transfer 0.5 ml of sterile DNA grade water into a labeled eppendorf tube. Transfer a loop-full of the colony into the tube and vortex. Make sure the tube is tightly sealed with the O-ring cap and vortex the tube to suspend the colony in the water.
- 8.2.4.7 Incubate tubes in a heating block set at 100°C for 10 minutes.
- 8.2.4.8 Centrifuge tubes for 1 minute at 13,000 rpm's in the microfuge.
- 8.2.4.9 The supernatant contains the crude DNA preparation that will be tested.

### 8.3 Real-Time Multiplex PCR on the Roche LightCycler

#### 8.3.1 Reagents

- 8.3.1.1 Roche LightCycler- DNA Master Hybridization Probes (Cat#12-158-825-001)
- 8.3.1.2 Forward and reverse primers for the amplification of Shiga toxin 1 and 2 DNA and for the detection of the O157:H7 genotype (developed by the CDC; manufactured by Operon; see Appendix 17.3 for sequences and Appendix section 17.4 for their preparation).
- 8.3.1.3 FRET fluorescent probes for detection of amplified Shiga toxin 1 and 2 DNA and for the detection of the O157:H7 genotype (developed by the CDC; manufactured by Idaho Technology; see Appendix 17.3 for sequences and Appendix 17.5 for their preparation).
- 8.3.1.4 Forward and reverse primers for the amplification of the internal control 16S ribosomal RNA gene (control reagents in LRN real-time PCR kits)
- 8.3.1.5 TaqMan probe for detection of the amplified internal 16S ribosomal RNA gene (control reagent in LRN real-time PCR kits).
- 8.3.1.6 EDL-933 positive control culture
- 8.3.1.7 10% bleach: Use spray bottle apparatus that has a water and concentrated bleach cartridge. When the trigger of the apparatus is pulled a spray of freshly prepared 10% bleach is delivered.

#### 8.3.2 Supplies

- 8.3.2.1 LightCycler capillary tubes and caps
- 8.3.2.2 Gloves and lab coat
- 8.3.2.3 Microfuge tubes-sterile
- 8.3.2.4 Sterile, plugged pipette tips
- 8.3.2.5 Absorbent, plastic-backed bench paper
- 8.3.2.6 Large plastic bags (area #1)
- 8.3.2.7 Biohazard bags

#### 8.3.3 Equipment

- 8.3.3.1 Clean-air hood
- 8.3.3.2 Pipettors
- 8.3.3.3 Quick spin microcentrifuge
- 8.3.3.4 Roche carousel centrifuge
- 8.3.3.5 Roche LightCycler, version 3.0

#### 8.3.4 Procedure

8.3.4.1 Three different master mixes are made; a Shiga toxin 1 and 2 PCR multiplex, the 16S internal extraction control PCR mix and the O157:H7 genotype PCR mix. The Shiga toxin and 16S reactions are amplified on the same carousel in the same LightCycler (Shiga toxin program). The O157:H7 reaction is run on a separate carousel on a separate LightCycler (O157:H7 program)

8.3.4.1.1 Master mixes are prepared for the amplification and detection of the Shiga toxins 1 and 2 and the internal control 16S ribosomal RNA gene using the following formulations (the work sheet in Appendix 17.2 show formulations for different sample sizes):

#### Shiga 1 and 2 toxin Multiplex Reaction

Reagent	µl per reaction	Final Concentration
Water	7.2	-
Enzyme Master Mix	2.0	-
25 mM Magnesium Chloride	1.6	3 mM*
Primers Shiga 1 (forward and reverse; 25 µM)	0.4	0.50 µM
Primers Shiga 2 (forward and reverse; 25 µM)	0.4	0.50 µM
Shiga 1 640 Probe (5 µM)	0.8	0.20 µM
Shiga 1 Fluorescent Probe (5 µM)	0.8	0.20 µM
Shiga 2 705 Probe (5 µM)	0.8	0.20 µM
Shiga 2 Fluorescent Probe (5 µM)	0.8	0.20µM
UNG	0.2	-

\* Includes 1 mM Magnesium Chloride included in the Enzyme Master Mix

#### 16S Internal Control

Reagent	µl per reaction	Final Concentration
Water	10	-
Enzyme Master Mix	2.0	-
25 mM Magnesium Chloride	1.6	3 mM*
Forward Primer 16S	0.4	-
Reverse Primer 16S	0.4	-
TaqMan Probe 16S	0.4	-
UNG	0.2	-

\* Includes 1 mM Magnesium Chloride included in the Enzyme Master Mix

8.3.4.1.2 The master mix is prepared for the amplification and detection of the O157:H7 genotype using the following formulations (the work sheet in Appendix 17.2 show formulations for different sample sizes):

O157:H7 PCR Reaction

Reagent	µl per reaction	Final Concentration
PCR Grade Water	8.8	-
Enzyme Master Mix	2.0	-
25 mM MgCl <sub>2</sub>	1.6	3 mM*
O157:H7 ForwardPrimer (25 µM)	0.4	0.50 µM
O157:H7 Reverse Primer (25 µM)	0.4	0.50 µM
O157:H7 640 Probe (5 µM)	0.8	0.20 µM
O157:H7 Fluor. Probe (5 µM)	0.8	0.20 µM
UNG	0.2	-

\* Includes 1 mM Magnesium Chloride included in the Enzyme Master Mix

- 8.3.4.2 Load the LightCycler carousel with the required number of capillary tubes and transfer 15 µl of each master mix into the designated capillary tubes according to the bench work sheet.
- 8.3.4.3 Place the carousel into a regular (not biohazard) plastic bag and transfer to area #2 bench where the DNA was prepared.
- 8.3.4.4 Transfer 5 µl of each sample DNA, negative control and positive control into designated capillary tubes as indicated on the work bench sheet. Seal each tube with a white cap.
- 8.3.4.5 Transfer the carousel to area #3 and place in the Roche carousel centrifuge. Close the lid and press the run button. The time and speed of the run is pre-set. When finished the open lid button will light up. Remove the carousel.
- 8.3.4.6 Turn on the LightCycler and computer. Open the program named "Shiga toxin" or O157:H7 (parameters of the program are shown in the table below), and initiate a self test. Indicate on the work sheet the result of the self test, and document the date of the color compensation file (ccc file) that is linked to the program.

Step	Shiga	O157:H7
UNG Incubation	50°C for 3 minutes	50°C for 3 minutes
Denaturation	94°C for 2 minutes	94°C for 2 minutes
Amplification	95°C for 0 seconds 50°C for 20 seconds; single acquisition 72°C for 30 seconds 40 cycles; Quantification Analysis Mode	95°C for 0 seconds 65°C for 10 seconds; single acquisition 72°C for 20 seconds 40 cycles; Quantification Analysis Mode
Melting Curve	95°C for 0 seconds 40°C for 10 seconds 95°C for 0 seconds; continuous acquisition; (0.2°C/sec) Melting Curve Analysis mode	95°C for 0 seconds 55°C for 10 seconds 95°C for 0 seconds; continuous acquisition; (0.2°C/sec) Melting Curve Analysis mode
Cooling	40°C for 2 minutes	40°C for 2 minutes

- 8.3.4.7 Place the carousel into the LightCycler chamber, close the lid, and click on the “run” button on the computer screen.
- 8.3.4.8 Save the experimental file in the computer data base using the same name written in the “file name” field on the bench work sheet. Press enter, enter the number of capillary tubes on the carousel, and click on the “enter samples later” button.
- 8.3.4.9 A new screen will appear and the program will initiate. Click on the flashing “edit samples” button.
- 8.3.4.10 The sample screen will re-appear. Click on the “clear sample list” button, and then enter “yes” to clear samples.
- 8.3.4.11 Enter each sample exactly as indicated on the work sheet. Press “done” and the computer screen will display the real-time PCR.
- 8.3.4.12 NOTE: The program is automatically linked to a “color compensation file” The name of this file (ccc plus the date the file was created) is displayed in the upper left hand corner of the screen. The compensation file automatically corrects for bleeding between the different fluorescence channels. **Failure to use the color compensation file will result in erroneous data analysis.** Document the date of the ccc file on the bench work sheet and check to make certain that the file is within 6 months of the creation date. If it is not, inform the supervisor that the file needs to be replaced.
- 8.3.4.13 The data is analyzed in sequence using the F1 (16S internal control), F2 (Shiga toxin 1 or O157:H7), and F3 (Shiga toxin 2) fluorescence channels.
- 8.3.4.14 The fluorescence channels are set on the “y” axis of the real-time PCR screen.

Set the channel to F1.

- 8.3.4.15 Find the "Select a Program" field and make sure it reads Amplification; segment 2. Next, click on the "quantification" button.
- 8.3.4.16 On the next screen set the following parameters:

Analysis:	Fixed points
Baseline:	Arithmetic
# of points:	2
- 8.3.4.17 Click on the "noise band". The screen will show the exponential curves and the horizontal background curves. Raise the red bar until it is just above the background curves. The table on the left will display CT values for positive reactions (only the 16S reactions should show positive results).
- 8.3.4.18 Click on the "analysis" tab, raise the green bar so that all curves just intersect it. This fine tunes CT values. Print the page for the records.
- 8.3.4.19. Return to the original real-time PCR screen by clicking on the "window" tab at the top of the screen and from the drop down menu select the #1 file. Change the channel on the "y" axis to read F2 to analyze Shiga toxin 1 or O157:H7 reactions.
- 8.3.4.20 Repeat steps 8.3.4.15-8.3.4.18. Change the y axis to read F3 and repeat steps 8.3.4.15-8.3.4.18 again to analyze the Shiga toxin 2 reactions.
- 8.3.4.21 The melting temperature of the Shiga toxin and O157:H7 positive reactions must now be analyzed. To do so return to the main screen by clicking on the "window" tab at the top of the screen and select file #1 from the drop down menu. Set the y axis to the F2 (Shiga toxin 1 and O157:H7) channel. Under the "Select a program" field, select Melting curve analysis. Then click on the "melting curve" button on the right of the screen.
- 8.3.4.22. The melting curve of all the reactions is displayed on the lower right graph. If the curves do not appear smooth, click on the box in the middle of the screen and drag it upwards until the curves appear smooth.
- 8.3.4.23 Click on the "Extra Manual TM" button. A screen will appear with the melting curve enlarged and four colored lines to the left of the screen. Click and drag one of the colored lines until it sits exactly at the peak of the curve.
- 8.3.4.24 The TM of the reaction will be displayed in a box at the bottom of the graph that corresponds with the line that was placed at the peak. Print a copy of this screen for the records.

8.3.4.25 Return to the real-time PCR screen as described previously. Change the channel to F3 for the analysis of the Shiga toxin 2 reactions. Repeat steps 8.3.4.15-8.3.4.24 to identify positive Shiga 2 toxin reactions and to identify the melting temperature of the reactions.

**9. Specific Quality Control Material to Use**

9.1 The CDC E. coli strain EDL 933 (Shiga 1 and 2 producer) is used as a positive extraction control. Both MacConkey's broth and single colony isolates on MacConkey's agar are used depending on whether enriched cultures or isolated colonies are being tested.

**10 Procedure Note**

10.1 The assay is not intended for use on primary stool specimens.

10.2 Stool specimens must be enriched in MacConkey's broth for at least 8 hours. Colonies isolated on MacConkey's agar can also be tested.

10.3 The analytical sensitivity of the test is 250 organisms per reaction.

**11 Expected Values**

11.1 The expected value (normal reference range) of this test is negative for Shiga 1 and Shiga 2 toxins and negative for the O157:H7 genotype.

**12. Interpretation of the Data**

12.1 Interpret positive versus negative results for the Shiga toxin assays according to the following Table:

Shiga 1	Shiga 2	16S	Results Interpretation
Negative	Negative	Positive	Shiga 1 toxin negative Shiga 2 toxin negative
Positive	Negative	Positive	Shiga 1 toxin positive Shiga 2 toxin negative
Positive	Negative	Negative	Shiga 1 toxin positive Shiga 2 toxin negative
Negative	Positive	Positive	Shiga 1 toxin negative Shiga 2 toxin positive
Negative	Positive	Negative	Shiga 1 toxin negative Shiga 2 toxin positive
Positive	Positive	Positive	Shiga 1 toxin positive Shiga 2 toxin positive
Positive	Positive	Negative	Shiga 1 toxin positive Shiga 2 toxin positive
Negative	Negative	Negative	Indeterminate

- 12.2 Interpret positive versus negative results for the O157:H7 genotype assay according to the following Table:

O157:H7	16S	Results Interpretation
Negative	Positive	O157:H7 genotype negative
Positive	Positive	O157:H7 genotype positive
Positive	Negative	O157:H7 genotype positive
Negative	Negative	Indeterminate

- 12.3 The following table displays acceptable melting temperatures (TM) for Shiga toxins 1 and 2. TMs for the positive reactions must correspond with one of the following in order for the results to be valid:

Toxin	Melting Temperature*
Shiga Toxin 1	68°C**
Shiga Toxin 1 Variants	62 °C and 65 °C
Shiga Toxin 2, 2c, 2d	71 °C**
Shiga Toxin 2e	66 °C
Shiga Toxin 2 Variants	51 °C, 55 °C, 63 °C
O157:H7 Genotype	67-68 °C

\* Temperatures +/- 1 °C of these temperatures is acceptable

\*\* Melting temperature of the CDC control strain EDL 933

### 13. Reporting Method

- 13.1 The technologist enters results onto the Specimen and Results Tracking form (see Appendix section 17.9) and signs and dates the bottom of the form.
- 13.2 The form, along with the bench work sheets, is forwarded to the supervisor for review.
- 13.3 The supervisor reviews the test, and the Specimen and Results Tracking form for accuracy.
- 13.4 The supervisor signs and dates the Specimen and Results Tracking form.
- 13.5 The Specimen and Results Tracking form is forwarded to the Enteric laboratory.
- 13.6 The Enteric laboratory reviews the test results and issues reports.



#### 14. Method Limitations

- 14.1 Stool specimens must be enriched for at least 8 hours before testing. Alternatively, single colonies isolated on agar plates can be tested.
- 14.2 **“This test was developed and its performance characteristics determined by the Illinois Department of Public Health, Chicago Molecular Laboratory. It has not been cleared or approved by the U.S. Food and Drug Administration. Results must be used in conjunction with conventional testing for the evaluation and management of the patient.”**
- 14.3 An accurate PCR test depends on proper specimen collection and transport. Substances inhibitory to the PCR reaction may be present in the patient specimen and co-purify with the RNA. In this case, there will be no amplification of the Shiga toxin DNA or the internal control 16S DNA and the test will be reported as “unsatisfactory”.

#### 15. Contingency Plans

- 15.1 If the test system is not operational before the test is initiated contact the supervisor. Arrangements should be made to have the test performed by the other Division laboratory if possible. Providers should be contacted if a long delay is anticipated.
- 15.2 If equipment is failing or non-functional contact the supervisor for immediate repair and/or replacement with equipment at the IDPH.
- 15.3 If the procedure has been initiated but cannot be completed for any reason contact the supervisor. Identify possible stop points when the processed specimens can be stored until the procedure can be completed

#### 16. References

- 16.1 Gavin PJ, Peterson LR, Pasquariello AC, et al. Evaluation of performance and potential clinical impact of ProSpecT shiga toxin *Escherichia coli* microplate assay for detection of shiga toxin-producing *E. coli* stool samples. *J. Clin. Microbiol.* 42:1652-1656, 2004.
- 16.2 Kehl SK, Havens P, Behnke CE, and Acheson WK. Evaluation of the Premier EHEC assay for detection of shiga toxin-producing *Escherichia coli*. *J. Clin. Microbiol.* 35:2051-2054, 1997.
- 16.3 Belanger SD, Moissinot M, Menard C, et al. Rapid detection of shiga toxin-producing bacteria in feces by multiplex PCR with molecular beacons on the smart cycler. *J. Clin. Microbiol.* 40:1436-1440, 2002.
- 16.4 Wang G, Clark CG, and Rodgers FG. Detection in *Escherichia coli* of the genes encoding the major virulence factors, the genes defining the O157:H7 serotype, and components of the type 2 shiga toxin family by multiplex PCR. *J. Clin. Microbiol.* 40:3613-3619, 2002.

- 16.5 Paton JC and Paton AW. Pathogenesis and diagnosis of shiga toxin-producing *Escherichia coli* infections. *Clin. Microbiol. Rev.* 11:450-479, 1998.
- 16.6a Reischl U, Youssef MT, Kilwinski J, et al. Real-time fluorescence PCR assays for detection and characterization of shiga toxin, intimin, and enterohemolysin genes from shiga toxin-producing *Escherichia coli*. *J. Clin. Microbiol.* 40:2555-2565, 2002.
- 16.6b Workshop on Methods for Shiga toxin-producing *Escherichia coli* (STEC) Surveillance. Eiha Hyytia-Trees, D.V.M., Ph.D. Diagnosis of diarrheagenic *Escherichia coli* and *Shigella* using the LightCycler. Centers for Disease Control and Prevention, Atlanta, Georgia, November, 2003.
- 16.7 Caprioli A, Tozzi AE, Rizzoni G, and Karch H. Non-O157 shiga toxin-producing *Escherichia coli* infections in Europe. *Emerg. Infect. Dis.* 3:578, 1997.
- 16.8 Armstrong GL, Hollingsworth J, and Morris JG. Emerging foodborne pathogens: *Escherichia coli* O157:H7 as a model of entry of a new pathogen into the food supply of the developed world. *Epidemiol. Rev.* 18:29-51, 1996.
- 16.9 Griffin PM, Ostroff S, Tauxe R, et al. Illnesses associated with *Escherichia coli* O157:H7 infections: a broad clinical spectrum.. *Ann. Intern. Med.* 109:705-712, 1988.
- 16.10 Mead PS, Slutsker, L, Dietz V, et al. Food-related illness and death in the United States. *Emerg. Infect. Dis.* 5:607-625, 1999.
- 16.11 March SB and Ratnam S. Sorbitol-MacConkey medium for detection of *Escherichia coli* O157:H7 associated with hemorrhagic colitis. *J. Clin. Microbiol.* 23:869-872, 1986.
- 16.12 Karmali MA. Infection by verocytotoxin-producing *Escherichia coli*. *Clin. Microbiol. Rev.* 2:15-38, 1989.
- 16.13 Roche Molecular Biochemicals LightCycler Operator's Manual, version 3.5. Roche Diagnostics GmbH. Roche Applied Science. 68298 Mannheim, Germany. October, 2000.
- 16.14 ROPure Infinity Premier Model Reverse Osmosis System, LT901X4. Barnstead/Thermolyne Corporation, 1997.
- 16.15 60 Liter Infinity Storage Reservoir, LT902X. Barnstead/Thermolyne Corporation, 1997.
- 16.16 Nanopure Infinity UV/UF System, LT899X. Barnstead/Thermolyne Corporation, 1998.
- 16.17 Procedure for Evaluation Accuracy and Precision of Rainin Pipettes, AB-15 R2. Rainin Instrument Company, Inc. 1994-1997.
- 16.18 Pipet Care and Maintenance, AB-14 R3. Rainin Instrument Company, Inc. 1994-1997.

17. **Appendix**

- 17.0 Work flow diagram
- 17.1 Bench work sheet-Shiga toxin/16S (front); O157:H7 (back)
- 17.2 Master Mix Calculations
- 17.3 Sequences
- 17.4 Instructions for the preparation and storage of PCR primers
- 17.5 Instructions for the preparation and storage of PCR probes
- 17.6 PCR Etiquette
- 17.7 Wipe Test Instructions
- 17.8 Light Cycler Maintenance Documentation Table
- 17.9 Specimen and Results Tracking Form

**17.0**  
**DETECTION OF SHIGA TOXINS 1 AND 2 BY PCR:**  
**WORK FLOW BETWEEN THE ENTERIC MOLECULAR LABORATORIES**  
**FOR SPECIMEN RECEIPT, TESTING, AND RESULTS REPORTING**

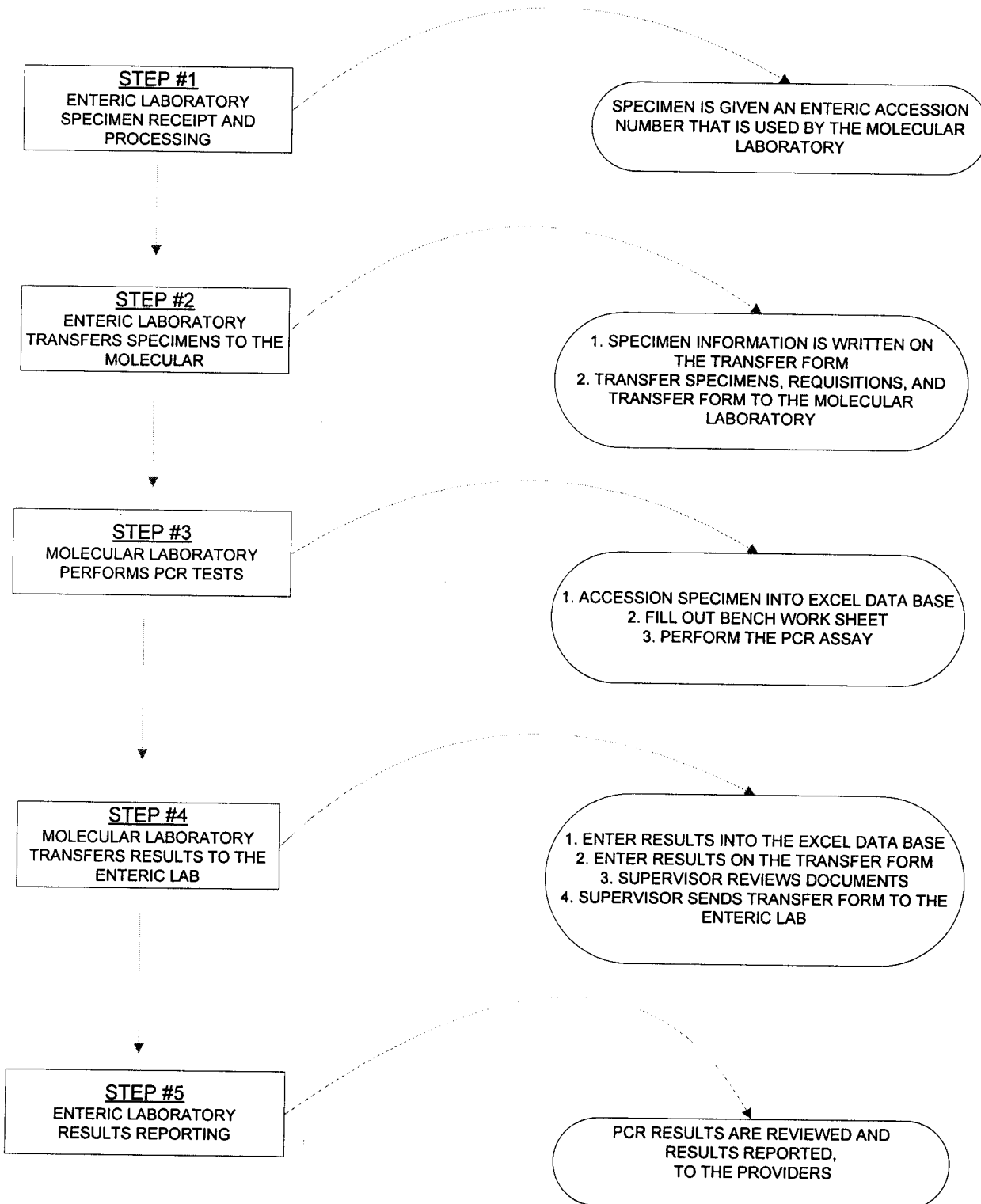

17.1

### BENCH WORK SHEET Shiga Toxin-Producing E. coli by PCR

LightCycler File		LightCycler Used	Self Check
Performed by:		A    B    C    D	Pass <input type="checkbox"/> Fail <input type="checkbox"/>
Date Tested		ccc.File date	

### LightCycler Carousel Specimen Map

	Sample	GENE	STX1	STX2	16S		Sample	GENE	STX1	STX2	16S
1						17					
2						18					
3						19					
4						20					
5						21					
6						22					
7						23					
8						24					
9						25					
10						26					
11						27					
12						28					
13						29					
14						30					
15						31					
16						32					

	LOT#	EXPIRATION
DNA Master Enzyme Kit		
UNG		
PRIMERS-STX		
PROBES-STX		
PRIMERS/PROBE-16S		
Water-Negative Control		
Positive Control		

<b>100°C Heating Block Temperature</b>
Range: 96-102°C

17.1 (back)

**BENCH WORK SHEET  
O157:H7 genotype E. coli by PCR**

LightCycler File		LightCycler Used	Self Check
Performed by:		A    B    C    D	Pass <input type="checkbox"/> Fail <input type="checkbox"/>
Date Tested		ccc.File date	

**LightCycler Carousel Specimen Map**

	Sample	GENE	RESULTS		Sample	GENE	RESULTS
1				17			
2				18			
3				19			
4				20			
5				21			
6				22			
7				23			
8				24			
9				25			
10				26			
11				27			
12				28			
13				29			
14				30			
15				31			
16				32			

	LOT#	EXPIRATION
DNA Master Enzyme Kit		
UNG		
PRIMERS-O157:H7		
PROBES-O157:H7		

17.2 Master mix formulations for Shiga toxins, O157:H7 genotype, and the 16S internal control

Multiplex PCR Mix for Shiga 1 and Shiga 2 Toxins

Reagent	1	2	3	4	5	6	7	8	9	10	11	12	13
PCR Grade Water	7.2	14.4	21.6	28.8	36	43.2	50.4	57.6	64.8	72	79.2	86.4	93.6
Enzyme Master Mix	2.0	4.0	6.0	8.0	10.0	12.0	14.0	16.0	18.0	20.0	22.0	24.0	26.0
25 mM MgCl <sub>2</sub>	1.6	3.2	4.8	6.4	8.0	9.6	11.2	12.8	14.4	16.0	17.6	19.2	20.8
Shiga 1 Primers (25 µM)	0.4	0.8	1.2	1.6	2.0	2.4	2.8	3.2	3.6	4.0	4.4	4.8	5.2
Shiga 2 Primers (25 µM)	0.4	0.8	1.2	1.6	2.0	2.4	2.8	3.2	3.6	4.0	4.4	4.8	5.2
Shiga 1 640 Probe (5 µM)	0.8	1.6	2.4	3.2	4.0	4.8	5.6	6.4	7.2	8.0	8.8	9.6	10.4
Shiga 1 Fluor. Probe (5 µM)	0.8	1.6	2.4	3.2	4.0	4.8	5.6	6.4	7.2	8.0	8.8	9.6	10.4
Shiga 2 705 Probe (5 µM)	0.8	1.6	2.4	3.2	4.0	4.8	5.6	6.4	7.2	8.0	8.8	9.6	10.4
Shiga 2 Fluor. Probe (5 µM)	0.8	1.6	2.4	3.2	4.0	4.8	5.6	6.4	7.2	8.0	8.8	9.6	10.4
UNG	0.2	0.4	0.6	0.8	1	1.2	1.4	1.6	1.8	2.0	2.2	2.4	2.6
Total Volume	15	30	45	60	75	90	105	120	135	150	165	180	195

PCR Mix for the Internal Control 16S

Reagent	1	2	3	4	5	6	7	8	9	10	11	12	13
PCR Grade Water	10	20	30	40	50	60	70	80	90	100	110	120	130
Enzyme Master Mix	2.0	4.0	6.0	8.0	10.0	12.0	14.0	16.0	18.0	20.0	22.0	24.0	26.0
25 mM MgCl <sub>2</sub>	1.6	3.2	4.8	6.4	8.0	9.6	11.2	12.8	14.4	16.0	17.6	19.2	20.8
Primer Forward	0.4	0.8	1.2	1.6	2.0	2.4	2.8	3.2	3.6	4.0	4.4	4.8	5.2
Primer Reverse	0.4	0.8	1.2	1.6	2.0	2.4	2.8	3.2	3.6	4.0	4.4	4.8	5.2
Taqman Probe	0.4	0.8	1.2	1.6	2.0	2.4	2.8	3.2	3.6	4.0	4.4	4.8	5.2
UNG	0.2	0.4	0.6	0.8	1	1.2	1.4	1.6	1.8	2.0	2.2	2.4	2.6
Total Volume	15	30	45	60	75	90	105	120	135	150	165	180	195

PCR Mix for the O157:H7 Genotype

Reagent	1	2	3	4	5	6	7	8	9	10	11	12	13
PCR Grade Water	8.8	17.6	26.4	35.2	44.0	52.8	61.6	70.4	79.2	88.0	96.8	105.6	114.4
Enzyme Master Mix	2.0	4.0	6.0	8.0	10.0	12.0	14.0	16.0	18.0	20.0	22.0	24.0	26.0
25 mM MgCl <sub>2</sub>	1.6	3.2	4.8	6.4	8.0	9.6	11.2	12.8	14.4	16.0	17.6	19.2	20.8
O157:H7 Forward Primer (25 M)	0.4	0.8	1.2	1.6	2.0	2.4	2.8	3.2	3.6	4.0	4.4	4.8	5.2
O157:H7 Reverse Primer (25 M)	0.4	0.8	1.2	1.6	2.0	2.4	2.8	3.2	3.6	4.0	4.4	4.8	5.2
O157:H7 640 Probe (5 µM)	0.8	1.6	2.4	3.2	4.0	4.8	5.6	6.4	7.2	8.0	8.8	9.6	10.4
O157:H7 Fluor. Probe (5 µM)	0.8	1.6	2.4	3.2	4.0	4.8	5.6	6.4	7.2	8.0	8.8	9.6	10.4
UNG	0.2	0.4	0.6	0.8	1	1.2	1.4	1.6	1.8	2.0	2.2	2.4	2.6
Total Volume	15	30	45	60	75	90	105	120	135	150	165	180	195

17.3 Sequences for primers and probes for the PCR test detecting Shiga toxins 1 and 2

Oligonucleotide	Sequence
Shiga toxin 1 PCR Primer	5'GARCRAAATAATTTATATGTG 3'
Shiga toxin 2 PCR Primer	5'TGATGATGRCAATTCAGTAT 3'
Shiga toxin 1 640 FRET Probe	5' <b>Red640</b> -TCGTACAACACTGGATGATCTCAGTGGG-Phos 3'
Shiga toxin 1 Fluorescent FRET Probe	5'TTTACGTTTTTCGGCAAATACAGAGGGGAT-FAM 3'
Shiga toxin 2 705 FRET Probe	5' <b>Red705</b> -ACCATGACGCCGGGAGACGTGGACCT-Phos 3'
Shiga toxin 2 Fluorescent FRET Probe	5'TCAGGCACTGTCTGAAACTGCTCCTGTGTA-FAM 3'
O157:H7 Forward Primer	5'GCGAAACTGTGGAATTGGG-3'
O157:H7 Reverse Primer	5'TGATGCTCCATCACTTCCTG-3'
O157:H7 Fluorescent FRET Probe	5'CGTAATTATGTGGGCAACGTCTGGT-FAM3'
O157:H7 640 FRET Probe	5' <b>Red640</b> -TCAGCGCGAAGTCTTTATACCGAAAGG-Phos3'



17.4 Instructions for the preparation and storage of PCR primers

Primers	Concentrated Stock	Working Stock
Shiga 1 toxin Primer	100 $\mu$ M	25 $\mu$ M
Shiga 2 toxin Primer	100 $\mu$ M	25 $\mu$ M
O157:H7 Forward Primer	250 $\mu$ M	25 $\mu$ M
O157:H7 Reverse Primer	250 $\mu$ M	25 $\mu$ M
16S Primers	-	-

17.4.1 Locate the  $\eta$ Mol value for each primer on the quality assurance document

17.4.1.1 Example: 67.6  $\eta$ Mole

17.4.2 The  $\eta$ Mol value is used to calculate the amount of water that is needed to achieve varying molarities of concentrated primer stocks. For instance, to make a 100  $\mu$ M concentrated stock, simply multiple 67.6 by a factor of 10

17.4.2.1 Thus, add 676  $\mu$ l water to the lyophilized primer tube to obtain a 100  $\mu$ M stock.

17.4.2.2 Alternatively, add 270  $\mu$ l water to the lyophilized primer tube to obtain a 250  $\mu$ M stock.

17.4.3 Aliquot this concentrated stock into a reasonable number of tubes. Ideally you will only thaw the stock once to make a working concentration. The rest are stored at  $-20^{\circ}\text{C}$

17.4.4 The working concentration of the primers is 25  $\mu$ M. To prepare the working concentration:

17.4.4.1 Add 10  $\mu$ l of the concentrated 100  $\mu$ M stock to 30  $\mu$ l water (1:4)

17.4.4.2 Add 10  $\mu$ l of the concentrated 250  $\mu$ M stock to 90  $\mu$ l water(1:10)

17.4.5 Aliquot the working stock into labeled tubes. Place one at  $4^{\circ}\text{C}$  and the rest at  $-20^{\circ}\text{C}$ . Do not freeze/thaw working stock.

17.4.6 The 16S internal control primers are provided by the CDC as a lyophilized pellet. Usually 250  $\mu$ l of water is added to reconstitute the primer. Instructions are included which each shipment for reconstitution. The primers are kept at  $4^{\circ}\text{C}$  and are used until the expiration date (displayed on the outside of the box).

17.5 Instructions for the preparation and storage of PCR probes

Probe	Concentrated Stock	Working Concentration
Shiga toxin 1 (640) FRET probe	20 $\mu$ M	5 $\mu$ M
Shiga toxin 1 Fluorescent FRET Probe	20 $\mu$ M	5 $\mu$ M
Shiga toxin 2 (705) FRET probe	20 $\mu$ M	5 $\mu$ M
Shiga toxin 2 Fluorescent FRET Probe	20 $\mu$ M	5 $\mu$ M
O157:H7 (640) FRET probe	20 $\mu$ M	5 $\mu$ M
O157:H7 Fluorescent FRET Probe	20 $\mu$ M	5 $\mu$ M
16S TaqMan probe	-	-

- 17.5.1 The Shiga toxin and O157:H7 probes arrive in solution from Idaho Technologies at 20  $\mu$ M
- 17.5.2 Aliquot the probes upon arrival and freeze at  $-20^{\circ}\text{C}$ . Do not expose to light and do not freeze/thaw.
- 17.5.3 To prepare the working concentration of probes, dilute the concentrated probe 1:4 with water (i.e., one part probe to three parts water).
- 17.5.4 Store the aliquoted probe at  $4^{\circ}\text{C}$  and do not expose to light.
- 17.5.5 The 16S internal control probe is provided by the CDC as a lyophilized pellet. Usually 250  $\mu$ l of water is added to reconstitute the primer. Instructions are included with each shipment for reconstitution. The primers are kept at  $4^{\circ}\text{C}$  and are used until the expiration date (displayed on the outside of the box).

17.6 PCR Etiquette

**17.6.1 AREA DEFINITIONS AND TRAFFIC FLOW**

AREA NUMBER	FUNCTION	CONTAMINATING MOLECULES	CONTAMINATION ISSUE	LABORATORY NUMBER(S)
Molecular Laboratory Area #1	MAKE ALL MASTER MIXES	NONE	GUARD AGAINST CONTAMINATION WITH NA AND AMPLICONS FROM AREAS #2 AND #3	338
Molecular Laboratory Area #2	SPECIMEN PREPARATION AND NA EXTRACTION	NUCLEIC ACID	GUARD AGAINST CONTAMINATION WITH NA AND AMPLICONS FROM AREA #3	339 347 BSL
Molecular Laboratory Area #3	AMPLIFICATION AND DETECTION OF AMPLICONS (amplified DNA)	AMPLICONS	DANGEROUS SOURCE OF AMPLICON CONTAMINATION FOR AREAS #1 AND #2	348

**17.6.1.1 (Area #1)** Of all the lab areas in the complex, it is most imperative that you guard against contamination in this area. This is where PCR master mix buffers are kept. They must be free of contaminating nucleic acid and amplicons (previously amplified DNA) or all your results will be false-positives. By analogy, this area is at the top of a waterfall. Your aim is to keep contaminating nucleic acid and amplicons from traveling upstream into this area. If you “room” around this room without gloves and lab coat you are a likely source of contamination. If you bring items previously kept in areas 2 or 3, they are likely sources of contamination.

**17.6.1.2 (Area #2)** This is the second cleanest area. Specimens are processed and nucleic acid is extracted in this area.. The area is regularly bleached to minimize contamination with nucleic acid from previous tests and/or with amplicons that made their way up the waterfall to area 2 from area 3. However, you have to assume that if you touch something in this area you may be picking up contaminating nucleic acid or amplicons. If you travel upstream into area #1 you are a potential source of contamination.

**17.6.1.3 (Area #3)** This is the most “dirty” area of the complex in that you must assume that the room is contaminated with amplicons. The room is bleached regularly to minimize the presence of amplicons on surfaces but if you rest your hand on a bench you may pick up amplicons. If you travel upstream to areas 1 and 2 you are likely a source of contamination.

## 17.6.2 Rules of Conduct

### 17.6.2.1 Area #1

- 17.6.2.1.1 Upon entering room put on gloves and lab coat (one that ties in the back) when working in hood.
- 17.6.2.1.2 Upon entering room put on gloves if you are only checking temperatures, stocks of reagents etc.
- 17.6.2.1.3 Never bring any item into the room if that item has been stored or placed in areas #2 and #3.
- 17.6.2.1.4 Never bring any nucleic acid or amplified material into the room.
- 17.6.2.1.5 Bleach PCR work stations before preparing master mixes.
- 17.6.2.1.6 Keep PCR work stations clean. Turn on UV light in the work station when not in use.
- 17.6.2.1.7 Once a week, clean common areas with bleach to include bench areas, freezer/refrigerator handles, entrance door, and other exposed surfaces.
- 17.6.2.1.8 Conduct a wipe test to check for the presence of contaminating amplicons/nucleic acid (see Appendix section 17.7 below for instructions on how to conduct this test).

### 17.6.2.2 Area #2

- 17.6.2.2.1 Wear lab coat and gloves stored in area #2 or they can be the same as worn in area #1. However, never re-enter area #1 with lab coats/gloves that were used in area
- 17.6.2.2.2 Clean all work station surfaces with bleach before you begin processing specimens
- 17.6.2.2.3 Work on absorbent white paper when practical.
- 17.6.2.2.4 Confine waste material from processing and nucleic acid extraction to the biohazard bins.
- 17.6.2.2.5 Bleach and clean work station surfaces when finished.
- 17.6.2.2.6 On a regular basis, bleach common areas such as door handles, refrigerator/freezer handles, pipettors and other surfaces that are commonly handled.
- 17.6.2.2.7 Never introduce amplified material into the area.

- 17.6.2.2.8 Conduct a wipe test to check for the presence of contaminating amplicons/nucleic acid (see Appendix section 17.7 below for instructions on how to conduct this test).

### 17.6.2.3 Area #3

- 17.6.2.3.1 Wear lab coat and gloves. These can be the same as worn in area #2. However, never re-enter areas #1 or #2 with lab coats/gloves used in area #3.
- 17.6.2.3.2 Amplified material must be confined in bags in the biohazard bin. LightCycler capillary tubes are placed in the sharps container.
- 17.6.2.3.3 Never carry amplified material out of the room unless confined as described above.
- 17.6.2.3.4 Never exit the room with contaminated gloves.
- 17.6.2.3.5 Bleach all carrier plates before returning them to area #2.
- 17.6.2.3.6 It is best to prop the doors open during work hours to avoid contamination inherent with touching the door handles. There are no biohazards in area #3 so air exchange is not a safety concern.
- 17.6.2.3.7 Clean all surfaces with bleach before you begin processing specimens.
- 17.6.2.3.8 Work on absorbent white paper when practical.
- 17.6.2.3.9 Bleach and clean the work station area when finished
- 17.6.2.3.10 On a regular basis, bleach common areas such as door handles, refrigerator/freezer handles, pipettors and other surfaces that are commonly handled.
- 17.6.2.3.11 Conduct a wipe test to check for the presence of contaminating amplicons/DNA (see Appendix section 17.7 below for instructions on how to conduct this test).

## 17.7 Molecular Biology Wipe Test

### 17.7.1 Protocol

- 17.7.1.1 A wipe test is conducted when the negative control in an assay demonstrates a positive amplification result. This is indicative of possible contamination of the work environment with either nucleic acid or amplicons (previously amplified material).
- 17.7.1.2 This wipe test will identify if and at what locations nucleic acid and /or amplicons are contaminating surfaces and instrumentation.
- 17.7.1.3 Identify areas to be surveyed and mark them in the appropriate fields on the Wipe Test bench work sheet (17.7.2). Include a positive and negative control for each test.
- 17.7.1.4 Label the appropriate number of eppendorf microfuge tubes corresponding to each area to be surveyed and for the controls.
- 17.7.1.5 Transfer 500 µl of water into each tube.
- 17.7.1.6 Use a sterile filter swab to survey each area. Insert the swab into the water in the tube, wipe a section of the area to be tested (DNA or amplicons will be picked up by the wet swab), and return the swab to the tube. Break off the end of the swab stick and seal the tube.
- 17.7.1.7 Repeat the process for each area to be tested. Make sure that you change gloves between swab sample collection.
- 17.7.1.8 For the negative control, insert a clean swab into the labeled tube, break off the stick, and seal the tube.
- 17.7.1.9 For the positive control, insert the swab into appropriate positive control as described in the SOP above, transfer swab to the labeled tube, break off the stick and seal the tube.
- 17.7.1.10 Vortex all tubes for 1 minute and centrifuge at 13,000 rpm's for 2 minutes at room temperature.
- 17.7.1.11 Follow directions in the manual for the preparation of the amplification master mix, operation of instrumentation, and analysis and interpretation of the data.
- 17.7.1.12 Identify areas that result in a positive amplification reaction. Note these areas on the bench work sheet. These are the areas that contain contaminating DNA or amplicons. Remember when analyzing the data the positive control must demonstrate a positive amplification result and the negative control must demonstrate a negative amplification result.
- 17.7.1.13 Areas testing positive and that are contaminated with DNA or amplicons must be cleaned with 10% bleach followed by extensive water rinsing.
- 17.7.1.14 The cleaned areas must be re-tested for contamination following steps 17.7.1.3-17.7.1.12 above.
- 17.7.1.15 The wipe test is concluded when all areas surveyed demonstrate a negative amplification result.

17.7.2

**Wipe Test Bench Work Sheet**

LightCycler File		LightCycler Used	Self Check
Performed by:		A    B    C	Pass <input type="checkbox"/> Fail <input type="checkbox"/>
Date Tested		ccc.File date	
Agent Tested			

Sample	Area Tested	Result	Remarks
1			
2			
3			
4			
5			
6			
7			
8			
9			
10			
11			
12			

	LOT#	EXPIRATION
DNA/RNA Master Enzyme Kit		
UNG		
PRIMERS		
PROBES		
Water-Negative Control		
Positive Control		

17.8

LightCycler Maintenance Documentation Table  
YEAR: \_\_\_\_\_

LightCycler A

	JAN	FEB	MAR	APR	MAY	JUNE	JULY	AUG	SEP	OCT	NOV	DEC
Clean Housing												
Clean Inside												
Change ccc file	x	x	ccc	x	x	x	x	x	ccc	x	x	x
Review												

LightCycler B

	JAN	FEB	MAR	APR	MAY	JUNE	JULY	AUG	SEP	OCT	NOV	DEC
Clean Housing												
Clean Inside												
Change ccc file	x	x	ccc	x	x	x	x	x	ccc	x	x	x
Review												

LightCycler C

	JAN	FEB	MAR	APR	MAY	JUNE	JULY	AUG	SEP	OCT	NOV	DEC
Clean Housing												
Clean Inside												
Change ccc file	x	x	ccc	x	x	x	x	x	ccc	x	x	x
Review												

LightCycler D

	JAN	FEB	MAR	APR	MAY	JUNE	JULY	AUG	SEP	OCT	NOV	DEC
Clean Housing												
Clean Inside												
Change ccc file	x	x	ccc	x	x	x	x	x	ccc	x	x	x
Review												

Frequency: Clean housing and the inside of the instrument monthly; change ccc file every six months.

See: Roche Molecular Biochemicals LightCycler Operator's Manual, version 3.5. Roche Diagnostics GmbH. Roche Applied Science. 68298 Mannheim, Germany. October, 2000.





17.9

### Specimen and Results Tracking Form

Specimen Number	Patient Name	Specimen Type Received by Enteric Laboratory	Specimen Type Transferred to Molecular	Date Transferred To Molecular	PCR Results STX 1	PCR Results STX 2	PCR Results O157

Performed by: \_\_\_\_\_ Date: \_\_\_\_\_  
Reviewed by: \_\_\_\_\_ Date: \_\_\_\_\_

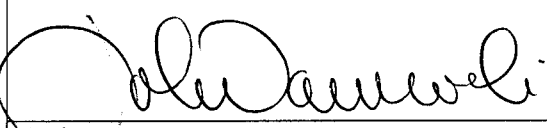
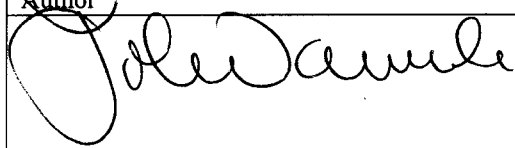
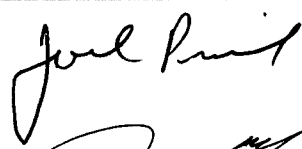
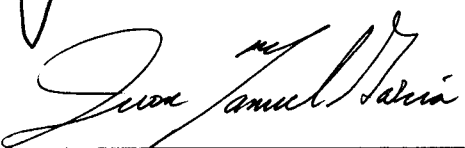
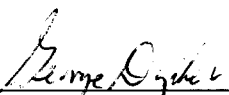
18. APPROVAL

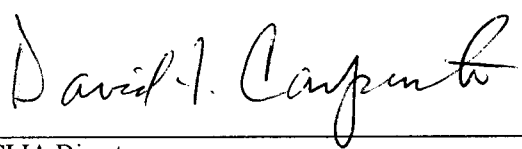
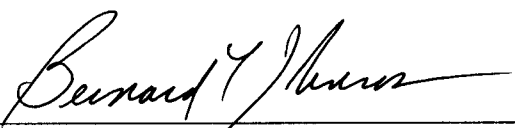
		1-29-08
Author		Date
		1-29-08
Technical Supervisor(s)		Date
		1-29-08
		02-11-08
Section Supervisor(s)		Date
		2-7-08
Laboratory Manager(s) as appropriate		Date
		2/11/08
QA Administrator, Division of Laboratories		Date
		2-18-08
CLIA Director		Date
		02/23/08
Chief, Division of Laboratories		Date

# **CHEERS QAPP 3**

## **Appendix 17: IDPH Laboratory Protocol: Norovirus**

STANDARD OPERATING PROCEDURE  
Illinois Department of Public Health – Division of Laboratories

Section:	
Title: Detection of Norovirus by real-time reverse transcriptase polymerase chain reaction	Effective Date: Upon Approval
	Revision No. 1
Author: John F. Nawrocki, Ph.D.	Reason for Revision: Method Change

**TEST NAME**

Detection of Norovirus by Real-time Reverse Transcriptase Polymerase Chain Reaction

**TABLE OF CONTENTS**

1. Principles .....	2
2. Requirements for Specimen Collection and Handling .....	3
3. Quality Control Statement .....	4
4. Safety .....	5
5. Overview of the Test .....	6
6. Reagents, Standards, and Controls .....	6
7. Instrumentation .....	8
8. Step-by-Step Directions .....	9
9. Specific Quality Control Material to Use .....	21
10. Procedure Note .....	21
11. Expected Values (Normal Range) .....	21
12. Interpretation of the Data .....	21
13. Reporting Method .....	22
14. Method Limitation .....	22
15. Contingency Plans .....	22
16. References .....	23

17. Appendix .....	26
18. Approval .....	46

## 1. Principle

- 1.1 The term Norovirus is used to describe a genus of small round structured viruses that are the principle agents of acute nonbacterial gastroenteritis (Cowden, 2002). The prototype virus was first identified in Norwak, Ohio in 1972 (Pringle, 1998) and is one of four genera of the family *Caliciviridae* (Cowden, 2002) along with Sapporo-like human caliciviruses, vesicular exanthema of swain-like viruses, and lapin caliciviruses (Berke and Matson, 2000). Norovirus has a positive-sense, single-stranded RNA genome of approximately 7700 nucleotides excluding the polyadenylated tail (Clarke and Lambden, 2001). The genome encodes three open reading frames (ORFs). ORF 1 is the largest and encodes a polyprotein precursor that is cleaved by the viral 3C-like protease. ORF2 encodes the viral capsid and ORF3 encodes a small basic protein of unknown function. Sequence analysis has suggested two major genogroups (G1 and G2) for the Norovirus (Ando et al., 2000; Noel and Fankhauser; 2000).
- 1.2 Infection with Norovirus can occur following ingestion of contaminated food (Berg et al., 2000) or water (Schvoerer et al., 1999), or by person-to-person contact in schools (Kobayashi et al., 1991), nursing homes ((Kaplan et al., 1982), hospitals (Stevenson et al.,1994), and cruise ships (Gunn et al.,1980; Koopmans et al, 2002; Cowden, 2002). The small infectious dose for Norovirus (10 to 100 organisms) makes control of viral spread exceedingly difficult (Cowden, 2002). Frequent hand washing and prompt disinfection help in the reduction of the spread of Norovirus, but aerosol spread after vomiting in close environments such as a hospital makes containment difficult. Thus incidence of Norovirus infection is higher in the winter and most outbreaks occur where people are in close proximity, such as on a cruise ship. The incubation period varies from 10 to 70 hours but is usually 24-48 hours. Symptoms include nausea, vomiting, diarrhea and stomach cramps. Patients suffer headache, fever, chills, and muscle aches. Although the illness resolves within 24-48 hours it can last a week or longer. Controlling the spread of the infection depends on good surveillance measures (Cowden, 2002).
- 1.3 Detection of the virus and diagnosis of the infection is hampered by the inability to grow the virus in culture. While electron microscopy has been routinely used for diagnosis, this method can only detect  $10^6$  viral particles or higher per ml of stool. The urgency to provide a more sensitive and rapid means of detecting Norovirus provides the impetus for the laboratory to develop a reverse-transcriptase polymerase chain reaction (RT-PCR) test.

- 1.4 Several Norovirus RT-PCR tests have been developed to detect both the G1 and G2 Norovirus subtypes. Genes targeted include the open reading frame 1 (ORF1) of the RNA-dependent RNA polymerase (RdRp) gene (Jiang et al, 1999; Moe et al., 1994; Nakayama et al., 1996; Vinje et al., 1996) or the ORF2 of the capsid protein gene (Wang et al., 1994; Yamazaki et al., 1996; Hafliger et al., 1997; Noel et al., 1997). There is no consensus on the most sensitive and discriminating assay and several studies have been made to compare these targets to identify the best-suited primers for RT-PCR (Vinje et al, 2003; Honma et al, 2000; Naitou and Morita, 2001). Kojima et al. (2002) developed primer sets to distinguish between the genogroups G1 and G2 using the capsid gene and developed a test with a higher detection rate than others (Kojima et al, 2002). The investigators further improved the sensitivity and specificity by developing genogroup specific primers that target the ORF1 and ORF2 junction and used the primers in a real-time quantitative RT-PCR assay using Taqman probes (Kageyama et al.,2003).
- 1.5 The IDPH-Chicago Laboratory has developed a real-time RT-PCR using the Roche LightCycler or ABI 7000 that is an adaptation of the test described by Kageyama et al. (2003). It is a non-quantitative test performed as a one-step RT-PCR assay in single, but separate, LightCycler capillary tubes for the detection of G1 and G2. A third extraction control reaction is performed for the amplification of kanamycin RNA.

## **2. Requirements for Specimen Collection and Handling (see SOP for Shipping, DOS010-00-0805 for further instructions).**

- 2.1 The test has only been validated for stool. A minimum of 100 mg of the stool specimen should be placed in a plastic, screw-cap container labeled with the full patient name, date of birth, and collection date. Ship the specimen on ice (4°C) by overnight delivery to the IDPH Chicago Laboratory. Upon receipt at the IDPH, specimens can be stored at 4°C for up to 60 days before testing. For long-term storage, specimens are stored at -70°C.
- 2.2 Unacceptable specimens include those with mismatched requisitions, specimens not shipped at 4°C, specimens without patient identifiers, and any non-stool specimens. In the last case supervisory approval is required for testing to proceed.
- 2.3 **An IDPH Communicable Diseases Laboratory Test Requisition** must accompany specimens that includes the test ordered, full patient name and identifiers (including sex and date of birth), source of specimen and date of collection, the submitting organization, referring physician if appropriate, and contact information. Test orders received over the telephone are acceptable and the test must be run according to the latest version of the CLIA regulations issued January 24, 2003. Historically we have been required to hold the sample until a written or electronic communication of the test requisition was sent to us. The new January 24 CFR modifies this requirement and allows us additional

flexibility, resulting in faster turnaround times. If a telephone request is accepted the laboratory must solicit a written or electronic authorization within 30 days of the oral request and must maintain the authorization or documentation of its efforts to obtain the authorization. This CFR was implemented on May 15, 2003 by the Division of Laboratories with the implementation of appropriate logs to document attempts to collect any missing information/test request. However, testing and reporting is not withheld due to lack of information.

### 3. Quality Control Statement

- 3.1 **Corrective Action Log:** Any deviations from the expected test performance are entered in the laboratory's standard Corrective Action Log. These include, but are not limited to, failures of positive and negative extraction and master mix controls. The log entries must include a statement of the problem, results of investigations into the deviations observed, actions taken to correct the problem, and the outcome of these actions.
- 3.2 **Controls:** For each batch of specimens tested a positive and negative extraction control is included. The test is only valid if G1 and G2 amplification is detected for the positive control, and neither G1 nor G2 amplification is detected for the negative control. In addition, bacterial RNA containing the kanamycin resistance gene is "seeded" into each specimen and control as an internal extraction control. This internal control tests for interfering substances or the loss of RNA during extraction. Any specimen testing negative for the amplification of Norovirus G1 or G2 must demonstrate a positive amplification of the kanamycin RNA to be valid. (Note: There is a standard base line amplification of the kanamycin RNA without template added. Therefore, the specimen must show amplification of kanamycin above this background.) If specimens test negative for both Norovirus and kanamycin the test needs to be repeated or the results are reported as indeterminate.
- 3.3 **Minimization and prevention of PCR contamination:** You must review procedures for the minimization and prevention of PCR contamination in this assay with your Supervisor before you initiate work on this test (see Appendix section 17.9; PCR Etiquette). Two sources of contamination are previously amplified DNA called amplicons, and DNA extracted from specimens in previous assays. Measures to prevent the contamination of your assay with either source are:
- 3.3.1 **Restricted Traffic Flow:** All transfer of reagents and supplies is restricted in the direction from area #1 (cleanest area used to prepare master mixes), to area #2 (DNA extraction) and finally to area #3 (amplification and detection of PCR products). Materials and supplies (including gloves and laboratory coats) should not be transferred from area to area in the opposite direction. All positive control materials are to be confined to area #3.

- 3.3.2 **Use of Amperase:** Amplicons are made with a nucleotide mix containing dUTPs. As potential contaminants in subsequent PCR reactions, these amplicons are destroyed by Uracil N-glycosylase (Amperase) which is included in all PCR reactions. Barring an overwhelming amplicon contamination, only DNA extracted from specimens will be amplified.
- 3.3.3 **Bleaching:** All surfaces and pipettes are wiped with 10% bleach before and after running the assay to destroy amplicons or DNA extracted from a previous assay.
- 3.3.4 **UV-irradiation:** When possible all operations are carried out in a biological safety cabinet or glove box equipped with UV lights. Before and after working in the hoods, the area is UV-irradiated (30 minutes-2 hours) which effectively destroys contaminating DNA and amplicons.
- 3.3.5 **Detection of Contamination** The negative extraction control tests for contaminating amplicons and/or RNA from the previous assay. If amplified Norovirus is detected in this control the assay is invalid and must be repeated. All work stations are rigorously cleaned and tested for Norovirus contamination before the test is repeated.
- 3.4 **Equipment Maintenance:** All equipment must be inspected and maintained according to the manufacturer's recommendations (16.27-16.34). Temperatures must be checked and recorded daily for refrigerators/freezers, water baths and other incubation devices. Pipetting devices must be calibrated at least every 6 months or according to the manufacturer's recommendations (16.33-16.34).
- 3.5 **Reagents:** Reagent lot numbers and expiration dates must be recorded on work sheets to insure that no expired reagent is used for testing. When new reagent lot numbers are used, results are checked with the same controls (lot numbers entered on the bench work sheet) to ensure results are the same as that obtained with old lot numbers.
- 3.6 **Competency and Proficiency tests:** Each technician must pass a **competency** test before they can perform the assay on patient specimens. This test is administered by the laboratory supervisor. The laboratory must subscribe (CAP or otherwise) to a **proficiency** program to evaluate the test performance on a regular basis (at least twice a year).

#### 4. Safety

- 4.1 Each laboratory section is responsible for maintaining a current awareness file of Occupational Health and Safety Act (OSHA) regulations regarding the safe handling of the chemicals specified in this method. A reference file of Material Safety Data Sheets (MSDS) is available to all personnel involved in this analysis.



Additional information on laboratory safety can be found in the Chemical Hygiene Plan and the Laboratory Safety Manual.

- 4.2 Specific to this procedure, safety and biohazard concerns are highlighted at the appropriate steps. The specific concern is indicated with procedures to protect you.

## 5. Overview of the Test

- 5.1 **Specimens processing:** Approximately 0.3 g of the stool specimen is transferred into a microfuge tube containing STE and glass beads. The specimen is vortexed and a clarified viral supernatant is prepared for RNA extraction.
- 5.2 **Viral RNA extraction** is done using the Qiagen QIAamp viral extraction kit (for small numbers of specimens) or the automated Roche MagNA Pure LC Instrument (for larger number of specimens).
- 5.3 **The real-time reverse transcription polymerase chain reaction** (real time RT-PCR) assay is performed for the detection of Norovirus. In general, the Roche LightCycler Instrument 1.2 is used for small number of specimens (RNA prepared using the Qiagen kit) and the ABI 7000 Instrument is used for larger number of specimens (RNA prepared using the MagNA Pure LC Instrument).
- 5.4 **Specimens that are negative for Norovirus** are subsequently analyzed for the amplification of kanamycin- RNA. If the kanamycin control is positive the test is valid and results are reported as negative for Norovirus viral genotypes G1 and G2. If, however, the kanamycin control is negative then it is likely that the control RNA, and by inference the specimen RNA, was degraded or lost during the extraction step. These tests are invalid and must be repeated.

## 6. Reagents, Standards, and Controls

- 6.1. **QIAamp Viral RNA Mini Kit-** Cat# 52904 (50 tests) or #52906 (250 tests); see the *QIAamp Viral RNA Mini Kit Handbook* in the Appendix (section 17.8.1) for detailed instructions for using this kit.
- 6.1.1 Buffer AVL (with carrier RNA added; stored at 4°C; warmed to room temperature to melt salt crystals before each extraction; try to minimize warm/chill cycle)
- 6.1.2 Carrier RNA-poly A (added to AVL)
- 6.1.3 Wash buffer AW1 (activate with ethanol added before use)
- 6.1.4 Wash Buffer AW2 (activate with ethanol added before use)
- 6.1.5 Buffer AVE (elution buffer)
- 6.1.6 QIAamp spin columns (used to collect and elute RNA)
- 6.1.7 QIAamp collection tubes (used to wash and dry RNA)

6.2 **Roche MagNA Pure LC Total Nucleic Acid Isolation Kit-** (Cat#3 038 505); see the MagNA Pure LC Total Nucleic Acid Isolation kit manual in the Appendix (section 17.8.2) for detailed instructions for using this kit.

- 6.2.1 Black bottle: Wash buffer I (for removal of PCR inhibitors)
- 6.2.2 Blue bottle: Wash buffer II (for removal of salts and proteins, etc.)
- 6.2.3 Red bottle: Wash buffer III (for removal of salts and proteins, etc.)
- 6.2.4 Green bottle: Lysis/binding buffer (for cell lysis and DNA binding)
- 6.2.5 Caramel bottle: Magnetic Glass Particles-MGPs (for binding DNA)
- 6.2.6 Yellow bottle: Elution buffer (for elution of DNA and reconstituting Proteinase-K)
- 6.2.7 Clear bottle: Bacterial lysis buffer (for external lysis only-not used)
- 6.2.8 Pink bottle: Proteinase-K (for protein digestion; supplied lyophilized; reconstitute with 5 ml of elution buffer and date bottle; store at 4°C for a maximum of two weeks.

6.3 **Plastic ware supplies used with the MagNA Pure LC Total Nucleic Acid Isolation Kit**

- 6.3.1 Large boats: Holds Wash buffers I and III
- 6.3.2 Medium boats: Holds all other reagents
- 6.3.3 Specimen cartridges: Holds specimens and extracted DNA
- 6.3.4 Tips: Blue (large) and yellow (small) used for pipettors
- 6.3.5 Tip holders: Holds Blue tips as staging areas during DNA extraction
- 6.3.6 Processing cartridges: DNA binding/washing
- 6.3.7 Waste bottle
- 6.3.8 Autoclave bags: Catches used tips that are ejected

6.4 **LightCycler RNA Amplification Kit Hybridization Probes (Cat# 12 015 145 001)** see the LightCycler RNA Amplification Kit HybProbe manual in the Appendix (section 17.8.3) for detailed instructions for using this kit.

- 6.4.1 Red cap #1: Enzyme Mix
- 6.4.2 Red cap #2: 5X reaction mix for RT-PCR
- 6.4.3 Blue cap #3: 25 mM MgCl<sub>2</sub>
- 6.4.4 Colorless cap #4: PCR-grade water

6.5 **Uracil-DNA Glycosylase (Roche Cat #11 775 367 001)**

- 6.5.1 Hydrolyzes uracil-glycosidic bonds present in amplicons.
- 6.5.2 Used to destroy amplicons from previous reactions that might be contaminating nucleic acid extracted from patient specimens or master mixes prepared for amplification.

- 6.6 **Controls** are not commercially available. The laboratory therefore must keep an inventory of stool specimens that previously tested positive for the presence of Norovirus, types G1 and G2. These specimen controls are inventoried with lot numbers and expiration dates.

## 7. Instrumentation

- 7.1 **Roche LightCycler Instruments 1.2 (Software Version 3.5)** These instruments perform the polymerase chain amplification and real-time detection (16.27). The instrument performs a self-check when used. Results of this self-check (pass or fail) are recorded on the bench work sheets (Appendix, 17.2) for the day's run. If the instrument fails, the specific information is recorded and the technical help support staff at Roche is contacted. If the problem persists, the instrument is sent back to Roche and they send out a loaner instrument. The outside and inside of the instruments are cleaned each month and the color compensation file is changed every six months. See reference 16.27 for more detailed instructions and Appendix section 17.11 for the maintenance log.

### 7.2 Roche MagNA Pure LC Instrument

- 7.2.1 This is an automated DNA extraction instrument. The user should become familiar with the instrument's instruction manual (16.33) along with the step-by-step instructions for use in section 8.3.

- 7.2.2 The following steps are performed to insure that the instrument is in proper working order (see Appendix sections 17.12 and 17.13 for documentation of these procedures:

- 7.2.2.1 The instrument stage is exposed to UV radiation for 8 hours overnight to destroy contaminating DNA.
- 7.2.2.2 The instrument handles and stage are wiped with 10% bleach every day to destroy contaminating DNA.
- 7.2.2.3 The O-rings are lubricated once month.
- 7.2.2.4 The O-rings are changed once a month and a leak test is performed.
- 7.2.2.5 The magnet is cleaned every month.

### 7.3 Applied Biosystems ABI Prism 7000 Instrument

- 7.3.1 This instrument has a 96-well plate format for the polymerase chain amplification and real-time detection as described in section 8.4.6.

- 7.3.2 The routine maintenance of this instrument is detailed in the operational manual (16.34) and includes the following procedures that are documented on the table included in Appendix, section 17.14.

- 7.3.2.1 Weekly Maintenance
  - 7.3.2.1.1 Check for well contamination
  - 7.3.2.1.2 Clean dirty wells
  - 7.3.2.1.3 Check system hardware
- 7.3.2.2 Monthly Maintenance
  - 7.3.2.2.1 Perform a background check
  - 7.3.2.2.2 Change compression pads
- 7.3.2.3 6 Month Maintenance
  - 7.3.2.3.1 Change lamp
  - 7.3.2.3.2 ROI calibration
  - 7.3.2.3.3 Background calibration
  - 7.3.2.3.4 FAM Spectral Calibration

## 8. Step-by-Step Directions

### 8.1 Preparation of Stool Specimens

#### 8.1.1 Reagents

- 8.1.1.1 STE (150 mM NaCl; 10 mM Tris-HCl, pH 8.0; 1 mM EDTA)
- 8.1.1.2 Pyrex glass beads-3 mM
- 8.1.1.3 Norovirus G1 and G2 positive controls
- 8.1.1.4 10% bleach spray bottle

#### 8.1.2 Supplies

- 8.1.2.1 Gloves and laboratory coat
- 8.1.2.2 Sterile, plugged pipette tips
- 8.1.2.3 Eppendorf microfuge tubes
- 8.1.2.4 Absorbent, plastic-backed bench paper
- 8.1.2.5 Biohazard waste containers

#### 8.1.3 Equipment:

- 8.1.3.1 Eppendorf refrigerated centrifuge 5417R
- 8.1.3.2 Biological safety cabinet (BSC)
- 8.1.3.3 Timer
- 8.1.3.4 Pipetman pipettors
- 8.1.3.5 Centrifuge racks for eppendorf tubes

8.1.3.6 Vortex

8.1.4 Procedure

8.1.4.1 Fill out a bench work sheet for RNA extraction (Appendix 17.1), and either a LightCycler amplification bench work sheet (Appendix 17.2) or a ABI 7000 Amplification bench work sheet (Appendix 17.3) depending on the method you are using. Generally, is small numbers of stool specimens are to be processed the Qiagen manual RNA extraction method is used along with the LightCycler for the PCR assay. For larger number of stools the MagNA Pure is used for RNA extraction along with the ABI 7000.

8.1.4.2 Label 1.5 ml microfuge tubes for each patient specimen to be tested, a negative extraction control, and a double positive (Norovirus G1 and G2) extraction control.

8.1.4.3 Transfer approximately ten (10) 3 mM glass beads into each tube.

8.1.4.4 Transfer 500 µl of STE into each tube.

8.1.4.5 Transfer 0.5-1.0 grams of the patient and positive control stools into each appropriately labeled tube. Perform these transfers in the BSC.

8.1.4.6 Vortex 5 seconds. Repeat the vortex step.

8.1.4.7 Centrifuge 3,000 x g at 4°C for 20 minutes in the Eppendorf microcentrifuge.

8.2 Extraction of Viral RNA with the Qiagen Extraction Ki

8.2.1 Reagents

8.2.1.1 Kanamycin RNA (control RNA in Progmega RT System Kit; Cat#A3500; dilute 1:200 for working stock).

8.2.1.2 Qiagen QIamp RNA Extraction Kit

8.2.1.3 Absolute ethanol

8.2.1.4 10% bleach wash bottle; has two cartridges (water and concentrated bleach); delivers a freshly prepared spray of 10% bleach when used.

8.2.2 Supplies

- 8.2.2.1 Gloves and laboratory coat
- 8.2.2.2 Sterile, plugged pipette tips
- 8.2.2.3 Eppendorf microfuge tubes
- 8.2.2.4 Absorbent, plastic-backed bench paper
- 8.2.2.5 Biohazard waste containers

### 8.2.3 Equipment

- 8.2.3.1 Qiagen Manifold
- 8.2.3.2 Biological Safety Cabinet (BSC)
- 8.2.3.3 Timer
- 8.2.3.4 Pipetman pipettors
- 8.2.3.5 Vortex

### 8.2.4 Procedure

- 8.2.4.1 Before you begin, make sure that the Qiagen RNA extraction kit is ready for use. If the kit is new, add the carrier RNA to the AVL buffer, and add absolute ethanol to wash buffers AW1 and AW2, respectively (refer to the Qiagen manual for instructions). If the kit has been opened, the AVL should be stored in the refrigerator and the carrier RNA will have precipitated. Remove the AVL from the refrigerator and shake the bottle in your hand in order to gently warm the bottle and re-dissolve the RNA. Do not place the bottle in a water bath.
- 8.2.4.2 During the centrifugation step in 8.1.4.7 above label 1.5 microfuge tubes for the patient specimens and double positive control, and negative control and transfer 560  $\mu$ l of buffer AVL into each tube.
- 8.2.4.3 Take the kanamycin RNA out of the freezer to thaw.
- 8.2.4.4 Following centrifugation, transfer 140  $\mu$ l of the patient and control viral supernatants into the tubes containing the AVL buffer and vortex thoroughly.
- 8.2.4.5 Transfer 1  $\mu$ l of the kanamycin RNA suspension into each tube. Vortex the tubes.
- 8.2.4.6 Incubate tubes at room temperature for 10 minutes. The sample is no longer infectious following this incubation. The remaining steps can be performed on the bench top.

- 8.2.4.7 Centrifuge tubes briefly to collect the suspension and add 560  $\mu$ l of absolute ethanol. Vortex and centrifuge briefly.
- 8.2.4.8 Label one RNA separation filter/collection tube assembly for each specimen and place it on the Qiagen manifold.
- 8.2.4.9 Transfer 630  $\mu$ l of the viral lysate into the filter, wait for the suction to pull the liquid through the filter and add the remaining viral lysate.
- 8.2.4.10 Repeat the process for all of the patient specimens and controls.
- 8.2.4.11 Transfer 500  $\mu$ l of wash buffer AW1. Wait until the vacuum pulls the liquid through the filter.
- 8.2.4.12 Transfer 500  $\mu$ l of wash buffer AW2. Wait until the vacuum pulls the liquid through the filter.
- 8.2.4.13 Remove the filter from the manifold and place in a collection tube. Centrifuge the tube for 4 minutes at 10,000 X g.
- 8.2.4.14 Label 1.5 ml microcentrifuge tubes with tough tags and transfer each filter to its corresponding tube.
- 8.2.4.15 Add 50  $\mu$ l of elution buffer taking care that the buffer is expelled directly onto the center of the filter.
- 8.2.4.16 Incubate for 1 minute at room temperature and then centrifuge at 7,000 X g for 1 minute to collect the RNA.
- 8.2.4.17 The RNA will be manually transferred into LightCycler capillary tubes containing reagent master mix as described in section 8.4.5.5.

### 8.3 Extraction of Viral RNA using the Roche MagNA Pure LC Instrument

#### 8.3.1 Reagents

- 8.3.1.1 MagNA Pure LC Total Nucleic Acid Isolation Kit (Roche Diagnostics Cat# 3 038 505)
- 8.3.1.2 Kanamycin RNA (control RNA in Progmega RT System Kit; Cat#A3500; dilute 1:200 for working stock).
- 8.3.1.3 STE (150 mM NaCl; 10 mM Tris-HCl, pH 8.0; 1 mM EDTA)

- 8.3.1.4 10% bleach wash bottle; has two cartridges (water and concentrated bleach); delivers a freshly prepared spray of 10% bleach when used.
- 8.3.1.5 10% ethanol wash bottle
- 8.3.2 Supplies
  - 8.3.2.1 Roche MagNA Pure accessories (see list above)
  - 8.3.2.2 Gloves and laboratory coat
  - 8.3.2.3 Plugged sterile pipette tips
  - 8.3.2.4 Biohazard bags
  - 8.3.2.5 Absorbent, plastic-backed bench paper
- 8.3.3 Equipment
  - 8.3.3.1 MagNA Pure LC Instrument
  - 8.3.3.2 Biological Safety Cabinet
  - 8.3.3.3 Pipetman pipettors
- 8.3.4 Procedure
  - 8.3.4.1 Initiate a bench work sheet (Appendix section 17.1 and 17.3). Fill in all fields to document lot numbers and expiration dates of reagents used. Fill in the MagNA Pure cartridge map on the reverse side of the work sheet. Note that the specimens and controls are loaded in the cartridge from right to left (A-H) in each of 4 rows for a total of 32 possible specimens including controls. The Norovirus double positive control always occupies well A1 and the negative extraction control always occupies well B1. A STE (without kanamycin RNA occupies the last well).
  - 8.3.4.2 Log onto the MagNA Pure computer and select the "Sample Ordering" screen from the main menu. From the "Sample Ordering" screen fill in the following areas:
    - 8.3.4.2.1 Enter each specimen identification so that the order list matches the cartridge map of the bench work sheet.
    - 8.3.4.2.2 Select Protocol: "Total NA External Lysis".
    - 8.3.4.2.3 Do not select a Post-Elution protocol.
    - 8.3.4.2.4 Enter 500  $\mu$ l for sample volume.
    - 8.3.4.2.5 Enter 100  $\mu$ l for elution volume.
  - 8.3.4.3 Click on the Stage Setup.



- 8.3.4.4 The Stage screen will appear. It will look exactly like the real stage of the MagNA Pure LC. Each reagent or supply will have its own box that will direct you where to load the reagent/supply and what volumes you need. Reagents are loaded into different sized boats. Follow the instructions in each box exactly and when you load an item click on the box on the screen. The description will change to an actual picture of the item. Load all of the items except for the specimen cartridge and the magnetic beads.
- 8.3.4.5 Transfer 300  $\mu$ l of the Lysis/binding buffer (blue buffer) into each well of the MagNA Pure LC sample cartridge. Transfer 4  $\mu$ l of the kanamycin internal extraction RNA into each well, except for the last well which is STE only. Following the plate map on the work bench sheet, transfer 200  $\mu$ l of each patient specimen into its designated well. Samples are loaded right to left. The first specimen is transferred into well C1, and second into D1, etc. When all the patient specimens have been loaded into the wells, transfer 200  $\mu$ l of STE into the well B1 designated for the negative control and in the last well which is STE only, 200  $\mu$ l of the Norovirus double positive control into well A1. Mix the contents of each well thoroughly and incubate the cartridge in the BSC for 10 minutes at room temperature.
- 8.3.4.6 At the end of the 10 minute incubation, load the magnetic beads onto the MagNA Pure LC stage. Make sure that you thoroughly re-suspend the beads before they are transferred to a reagent boat. Click on the picture of the beads.
- 8.3.4.7 Transfer the sample cartridge from the BSC to the MagNA Pure stage and click on the picture of the cartridge. An "OK" icon will appear on the bottom right of the screen when all of the reagent and supply boxes have been clicked on.
- 8.3.4.8 Click the OK block to initiate the run. Upon doing so, a progress screen appears showing the total time of the run, with a red bar progressing across the screen that indicates the current status of the run.
- 8.3.4.9 At the end of the run, the RNA extracted from each specimen will be transferred to the sample cartridge held in the 4°C cooling block in the upper right hand corner of the MagNA Pure stage.

- 8.3.4.10 Remove all reagents and waste except the extracted RNA. The RNA will be transferred into an ABI 7000 master mix plate as described in section 8.4.6.5.

## 8.4 Real-time Reverse Transcriptase Polymerase Chain Reaction

### 8.4.1 Reagents

- 8.4.1.1 Roche LightCycler RNA Master Hybridization Probes (Cat#12 015 145)
- 8.4.1.2 Norovirus G1 and G2 forward and reverse PCR primers (Operon; see Appendix 17.5 and 17.6 for sequence information and preparation).
- 8.4.1.3 Norovirus Ring1a, Ring1b and Ring 2 TaqMan FAM-labeled probes (Applied Biosystems; see Appendix 17.5 and 17.7 for sequences and preparation).
- 8.4.1.4 Kanamycin forward and reverse primers (Operon; see 17.5 and 17.6 for sequences and preparation).
- 8.4.1.5 Kanamycin TaqMan FAM-labeled probe (Applied Biosystems; see Appendix 17.5 and 17.7 for sequence and preparation).
- 8.4.1.6 Uracil-DNA Glycosylase (Roche 11 466 646 001).

### 8.4.2 Supplies

- 8.4.2.1 LightCycler capillary tubes and caps
- 8.4.2.2 Gloves and lab coat
- 8.4.2.3 Microfuge tubes-sterile
- 8.4.2.4 Sterile, plugged pipette tips
- 8.4.2.5 Absorbent, plastic-backed bench paper
- 8.4.2.6 Large plastic bags (area #1)
- 8.4.2.7 ABI 7000 Optical 96-well reaction plate (N801-0506)
- 8.4.2.8 ABI 7000 Optical Adhesive Covers (#4311971)
- 8.4.2.9 MagNA Pure LC Cartridge Seal (03-118-827-001)

### 8.4.3 Equipment:

- 8.4.3.1 Microcentrifuge
- 8.4.3.2 LightCycler Instrument 1.2 carousel
- 8.4.3.3 LightCycler Instrument 1.2 (software version 3.5) with computer and printer
- 8.4.3.4 LightCycler carousel centrifuge
- 8.4.3.5 Vortex
- 8.4.3.6 ABI 7000 Instrument
- 8.4.3.7 96-well plate centrifuge

#### 8.4.4 Preparation of the reverse-transcriptase master mix

8.4.4.1 Thaw all reagents required for the preparation of the master mix from the Roche kit. Working stocks of the primers and probes are kept at 4°C. See the Appendix section 17.6 and 17.7 for preparation of these reagents.

8.4.4.2 Prepare the master mix according to the following table depicting volume of each reagent per reaction. Include a water control for the kanamycin master mix. Each reaction includes 15 µl of this mix and 5 µl of sample RNA, control RNA or water (standard control for Kanamycin amplification without template). Prepare an extra reaction for each master mix. A table with master mix calculations for various number of specimens is included in Appendix section 17.4.

G1 Master Mix	µl	G2 Master Mix	µl	Kanamycin Master Mix	µl
Forward Primer (16 µM)	0.5	Forward Primer (16 µM)	0.5	Forward Primer (16 µM)	0.5
Reverse Primer (16 µM)	0.5	Reverse Primer (16 µM)	0.5	Reverse Primer (16 µM)	0.5
Probe Ring 1a-600pM	0.5	Probe Ring 2-200 pM	0.5	Probe-K-600pM	0.5
Probe Ring 1b-200pM	0.5				
25 mM MgCl <sub>2</sub>	3.2	25 mM MgCl <sub>2</sub>	3.2	25 mM MgCl <sub>2</sub>	3.2
Reagent Mix-Cap#2	4.0	Reagent Mix-Cap#2	4.0	Reagent Mix-Cap#2	4.0
Enzyme-Cap#1	0.4	Enzyme-Cap#1	0.4	Enzyme-Cap#1	0.4
UNG	0.2	UNG	0.2	UNG	0.2
PCR-Grade Water	5.2	PCR-Grade Water	5.7	PCR-Grade Water	5.7

8.4.4.3 Vortex each master mix thoroughly and centrifuge briefly.

8.4.4.4 Use the master mixes for amplification and detection on either the Roche LightCycler (section 8.4.5) or the ABI 7000 (section 8.4.6).

#### 8.4.5 Amplification using the Roche 1.2 LightCycler with Software 3.5

8.4.5.1 Turn on the computer and LightCycler.

8.4.5.2 Open the program for amplification and detection of Norovirus.

8.4.5.3 Initiate the self-check program for the LightCycler and denote pass or fail on the bench work sheet. Only use the LightCycler if the test passes. Document the color compensation file date on the bench work sheet.

8.4.5.4 Load the appropriate number of LightCycler capillary tubes on the carousel wheel and transfer 15 µl of each master mix (G1, G2, and kanamycin prepared in step 8.4.4.4 above) into the designated capillary tubes according to the plate map on

the designated capillary tubes according to the plate map on the bench work sheet (Appendix 17.2). NOTE: Make sure that you provide one extra kanamycin master mix tube for a water only control (provides base line amplification of kanamycin without template). Place the carousel into a plastic bag and carry it to the RNA processing station in area #2.

- 8.4.5.5 Transfer 5 µl of each patient sample and control into its designated capillary tube.
- 8.4.5.6 After loading specimens, seal each capillary tube with a white cap.
- 8.4.5.7 Transfer the carousel into area #3 and place in the carousel centrifuge. Press start. The centrifuge will spin at a pre-set speed and time.
- 8.4.5.8 Remove the carousel and visually inspect each tube to make certain that they all have approximately the same amount of reagent. Any tubes that have a significantly less volume indicates that the tube receive an inappropriate amount of master mix or specimen.
- 8.4.5.9 Place the carousel into the LightCycler instrument.
- 8.4.5.10 Click on the “RUN” icon. A pop-up window will appear asking you to save the experiment. Save the run using the file name on the bench work sheet (usually Norovirus plus the date).
- 8.4.5.11 A specimen entry screen will appear. On the bottom mid-left a window will have a default number of capillary tubes set at 32. Change this window to reflect the actual number of capillary tubes that are on the carousel. Click on “enter specimens later”. This will enable the machine to begin cycling without waiting for you to fill out this screen.
- 8.4.5.12 A blinking icon will appear that reminds you to edit samples. Click on this icon to return to the specimen entry screen.
- 8.4.5.13 Enter a description for each capillary tube in the window provided. The window also has a dropdown menu to identify each sample as unknown, positive, negative or standard. Select the appropriate listing for each sample.

- 8.4.5.14 When you are finished click on “done”. The screen should change to the real-time PCR amplification screen.
- 8.4.5.15 The run will start automatically with the following parameters:
- 8.4.5.15.1 Reverse Transcription: 48°C for 30 minutes
  - 8.4.5.15.2 Amperase Incubation: 50°C for 3 minutes
  - 8.4.5.15.3 Denaturation: 95°C for 10 minutes
  - 8.4.4.15.4 Amplification 40 Cycles.  
95°C; 15 seconds  
56°C; 60 seconds (Single acquisition)
  - 8.4.4.15.5 Cooling: 40°C; 30 Sec
- 8.4.5.16 When the run is finished the main Data Analysis Screen will automatically appear.
- 8.4.5.17 Amplification is read in the F1 channel.
- 8.4.5.18 Set the Y-axis on the graph at the bottom of the screen to F1.
- 8.4.5.19 Click on the “Quantification” icon at the top of the screen.
- 8.4.5.20 The next screen will show the amplification plots for all capillary tubes using software marketed by Roche. We do not use this software for final analysis of the data.
- 8.4.5.21 At the top left of the screen click on Fix points (Analysis) and arithmetic (Baseline Adjustment). Make sure the # of points is 2.
- 8.4.5.22 Analyze the G1 and G2 results first by selecting appropriate reactions.
- 8.4.5.23 Click on the “noise” tab for the large data display window.
- 8.4.5.24 Raise the red bar until it is just above all of the background noise curves.
- 8.4.5.25 Click on the “analysis” window and raise the green bar so that it passes through all of the amplification curves. The Table at the left of the screen displays the capillary tubes and shows a CT value for the positive reactions and no value for the negative reaction.

- 8.4.5.26 Print the screen for the permanent records (select file in the upper left hand corner, and then print page).
  - 8.4.5.27 The kanamycin reactions are analyzed next. Return to the “noise” window, select only the kanamycin reactions, and repeat steps 8.4.5.22 through 8.4.5.26 above. Note that even the negative (water control) will yield a positive kanamycin reaction. If possible, raise the red bar in the noise screen above the negative control to set it as background. The value of the CT for each specimen must be less than that of the water negative control in order for the specimen kanamycin test to be positive.
  - 8.4.5.28 Specimens that test negative for Norovirus must have a positive kanamycin internal control reaction to be valid. If they have a negative kanamycin reaction the test is indeterminate and has to be repeated.
  - 8.4.5.29 Remove the carousel, dispose the LightCycler tubes in the biohazard bin, briefly submerge the carousel in 10% bleach, rinse thoroughly, and air dry.
  - 8.4.5.30 Exit the program and turn off the LightCycler.
- 8.4.6 Amplification and detection of Norovirus on the ABI 7000
- 8.4.6.1 Turn on the ABI 7000 instrument so that it can warm up for at least 15 minutes before using. Turn on its interfacing computer and open the file “Norovirus”. The parameters of the program are as shown in 8.4.5.15.
  - 8.4.6.2 Adjust the template of the program to match the bench work sheet map (Appendix section 17.3). Save the file under the folder “Norovirus” and name the file to match the file name on the bench work sheet.
  - 8.4.6.3 Select the “instrument” tab. This screen will not only show the parameters of the program, but contains the “start” button.
  - 8.4.6.4 Load the 96-well ABI 7000 amplification plate with master mixes G1, G2, and kanamycin (see step 8.4.4.4) according to the plate map on the bench work sheet (Appendix 17.3). Place the plate in a plastic bag and transfer to the MagNA Pure LC instrument.

- 8.4.6.5 Place the master mix plate onto the stage of the MagNA Pure (into the cooling block) and open a Norovirus post-elution program which matches the number specimens extracted on the MagNA Pure. Place an adequate supply of yellow tips onto the stage and initiate the program.
- 8.4.6.6 At the end of the program remove the master mix plate and seal with an optical adhesive cover. Remove the sample cartridge containing the extracted RNA, cover with a cartridge seal, and store at  $-70^{\circ}\text{C}$ . Make sure that the MagNA Pure stage is cleaned and the decontamination program is initiated.
- 8.4.6.7 Centrifuge the sealed 96-well plate in the Eppendorf plate centrifuge. Select program #3 which will automatically centrifuge the plate for 1 minute at 1000 x g. After centrifugation, inspect the plate to ensure that there are no bubbles in any of the wells. Re-centrifuge if necessary, or lightly tap the plate on the bench counter top to displace any remaining bubbles.
- 8.4.6.8 Place a plate adapter on the ABI 7000 block, insert the master mix plate, and cover the plate with a heating pad. Carefully close the door.
- 8.4.6.9 Initiate the program by selecting start. This screen will show that the program has initialized and will indicate the approximate time of the run and the current stage of the run.
- 8.4.6.10 The real-time amplification screen can be accessed by selecting "amplification". On the next screen click the upper left hand box in the table at the bottom of the screen to show the reaction for all the wells. Subsequently the top and left margins of the table can be highlighted to display individual rows or wells.
- 8.4.6.11 When the run is complete, a red bar will appear at the bottom of the amplification plot. Identify the cycle at which the first exponential curve appeared and subtract one. Enter this number into end cycle box on the right of the screen. Click on "analyze". The bar will turn to green. Move the green bar using the mouse until it is above any "noise" lines.

- 8.4.6.12 Click on “analyze” again. This will set all positive reactions and assign them a CT value on the report. Negative reactions will be listed as undetected on the report.
- 8.4.6.13 Access the report, click on report on the tool bar and print the report. Transfer the information for each well or reaction onto the bench work sheet.
- 8.4.6.14 See 8.4.5.27 above for analysis and interpretation of the kanamycin internal control amplification.

**9. Specific Quality Control Material to Use**

- 9.1 Positive control material is not available commercially. Therefore the laboratory has to rely on archived specimens previously tested for the presence of Norovirus types G1 and G2.
- 9.2 The laboratory participates in a proficiency testing program with other state health laboratories. This material provides a means to assess the assay twice a year and provides reference control material for the test.

**10. Procedure Note**

- 10.1 The sensitivity of this test has not been determined.

**11. Expected Value (Normal Range)**

- 11.1 The normal range for this test is negative for the detection of Norovirus, types G1 and G2.

**12. Interpretation of the Data**

- 12.1 Results obtained from the LightCycler assay is interpreted as shown in the following Table:

G1	G2	Kanamycin Resistance	Result Interpretation
Negative	Negative	Positive	G1/G2 Negative
Positive	Negative	Positive	G1 +/ G2-
Positive	Negative	Negative	G1+/G2-
Negative	Positive	Positive	G1-/G2+
Negative	Positive	Negative	G1-/G2+
Positive	Positive	Positive	G1+/G2+
Positive	Positive	Negative	G1+/G2+
Negative	Negative	Negative	Indeterminate



### 13. Reporting Method

- 13.1 Patient reports are not generated. This is an epidemiological test. The results for all patients are grouped onto a one-page report that is sent to the state or local health department requesting the test. The following procedure is used to generate this grouped report:
  - 13.1.1 The template for the grouped report is stored on the G drive for molecular biology.
  - 13.1.2 When you have opened the template enter patient names and the results of the test.
  - 13.1.3 Print the grouped report, sign and date, and give it to the supervisor.
  - 13.1.4 The grouped report is sent and FAXed to the provider and IDPH Infectious disease in Springfield, IL.
  - 13.1.5 A copy of the report is archived in a binder labeled "Norwalk-Like PCR Results".

### 14. Method Limitation

- 14.1 The test has not been cleared by the FDA. The test was developed and performance properties determined by the Illinois Department of Public Health.
- 14.2 Sensitivity of the test has not been established. It is possible to obtain a false negative result if the concentration of virus is too low for the test to detect it.
- 14.3 The primer pairs used for amplification may not be able to detect all strains of G1 and G2 subtypes. It is therefore possible to obtain a false negative result if such a strain is present in a patient specimen.
- 14.4 It is not possible to identify subtypes within the groups G1 and G2.
- 14.5 Substances inhibitory to the PCR reaction may be present in the patient specimen and co-purify with the RNA. In this case, there will be no amplification of Norovirus RNA or the internal control kanamycin RNA and the test will be reported as "invalid".

### 15. Contingency Plans

- 15.1 If the test system is not operational before the test is initiated contact the supervisor. Arrangements should be made to have the test performed by the Springfield laboratory if possible. Providers should be contacted if a long delay is anticipated.
- 15.2 If equipment is failing or non-functional contact the supervisor for immediate repair and/or replacement with equipment at the IDPH.
- 15.3 If the procedure has been initiated but can not be completed for any reason, contact the supervisor. Identify possible stop points when the processed specimens can be stored until the procedure can be completed.

## 16. References

- 16.1 Ando T, Noel JS, Fankhauser RL. Genetic classification of "Norwalk-like viruses". *J. Infect. Dis. Suppl* 2:S336-348, 2000.
- 16.2 Berke T, and Matson DO. Reclassification of the Caliciviridae into distinct genera and exclusion of hepatitis E virus from the family on the basis of comparative phylogenetic analysis. *Archives of Virology*. 145:1421-1436, 2000.
- 16.3 Clarke IN, and Lambden PR. The molecular biology of human caliciviruses. *Novartis Found. Symp.* 238:180-191, 2001.
- 16.4 Cowden JM. Winter Vomiting. *BMJ*. 324:249-250, 2002.
- 16.5 Green SR, Moe CL, Jaykus LA, et al. Evaluation of the NucliSens basic kit assay for detection of Norwalk virus RNA in stool specimens. *J. Virol. Methods*. 108:123-131, 2003.
- 16.6 Gunn RA, Terranova WA, Greenberg HB, et al. Norwalk virus gastroenteritis aboard a cruise ship: an outbreak on five consecutive cruises. *Am. J. Epidemiol.* 112:820-827, 1997.
- 16.7 Hafliger D, Gilgen M, Luthy J, et al. Seminested RT-PCR systems for small round structured viruses and detection of enteric viruses in seafood. *Int. J. Food Microbiol.* 37:27-36, 1997.
- 16.8 Honma S, Nakata S, et al. Evaluation of nine sets of PCR primers in the RNA dependent polymerase region for detection and differentiation of members of the family Caliciviridae, Norwalk virus and Sapporo virus. *Microbiol. Immunol.* 44:411-419, 2000.
- 16.9 Jiang X, Huang PW, Zhong, WM, et al. Design and evaluation of a primer pair that detects both Norwalk-and Sapporo-like caliciviruses by RT-PCR. *J. Virol. Methods*. 83:145-154, 1999.
- 16.10 Kaplan JE, Schonberger LB, Varano G, et al. An outbreak of acute nonbacterial gastroenteritis in a nursing home. Demonstration of person-to-person transmission by temporal clustering of cases. *Am. J. Epidemiol.* 116:940-948, 1982.
- 16.11 Katayama K, Shirato-Horikoshi H, Kohima S, et al. Phylogenetic analysis of the complete genome of 18 Norwalk-like viruses. *Virology*. 299:225-239, 2002.
- 16.12 Kageyama T, Kojima S, Shinohara M. et al. Broadly reactive and highly sensitive assay for Norwalk-Like viruses based on real-time quantitative reverse transcription-PCR. *J. Clin. Microbiol.* 41:1548-1557, 2003.

- 16.13 Kobayashi S, Morishita T, Yamashita T, et al. A large outbreak of gastroenteritis associated with a small round structured virus among schoolchildren and teachers in Japan. *Epidemiol. Infect.* 107:81-86, 1991.
- 16.14 Kojima S, Kageyama T, Fukushi S, et al. Genogroup-specific PCR primers for detection of Norwalk-like viruses. *J. Virol. Methods.* 100:107-114, 2002.
- 16.15 Koopmans M, von Bonsdorff CH, Vinje J. et al. Foodborne Viruses. *FEMS Microbiol. Rev.* 26: 187-205, 2002.
- 16.16 Miller I, Gunson R, Carman WF. Norwalk like virus by light cycler PCR. *J. Clin. Virol.* 25:231-232, 2002.
- 16.17 Moe CL, Gentsch J, Ando T., et al. Application of PCR to detect Norwalk virus in fecal specimens from outbreaks of gastroenteritis. *J. Clin. Microbiol.* 32:642-648, 1994.
- 16.18 Naitou H, and Morita T. Selection of more appropriate PCR primer pairs for improved efficiency in detecting Norwalk-like virus (NLV) RNA. *J. Gen. Appl. Microbiol.* 47:241-246, 2001.
- 16.19 Nakayama M, Ueda Y, Kawamoto H, et al. Detection and sequencing of Norwalk-like viruses from stools samples in Japan using reverse transcription-polymerase chain reaction amplification. *Microbiol. Immunol.* 40:317-320, 1996.
- 16.20 Noel JS, Ando T, Leite JP, et al. Correlation of patient immune responses with genetically characterized small round-structured viruses involved in outbreaks of nonbacterial acute gastroenteritis in the United States, 1990 to 1995. *J. Med. Virol.* 53:372-383, 1997.
- 16.21 Schvoerer E, Bonnet F, Dubois V, et al. A hospital outbreak of gastroenteritis possibly related to the contamination of tap water by a small round structured virus. *J. Hosp. Infect.* 43:149-154, 1999.
- 16.22 Stevenson P, McCann R, Duthie R, et al. A hospital outbreak due to Norwalk virus. *J. Hosp. Infect.* 26:261-272, 1994.
- 16.23 Vinje J and Koopmans. Molecular detection and epidemiology of small round-structured viruses in outbreaks of gastroenteritis in the Netherlands. *J. Infect. Dis.* 174:610-615, 1996.
- 16.24 Vinje J, Vennema H, von Bonsdorff CH, et al. International collaborative study to compare reverse transcript PCR assays for detection and genotyping of noroviruses. *J. Clin. Microbiol.* 41:1423-1433, 2003.
- 16.25 Wang J, Jiang X, Madore HP, et al. Sequence diversity of small round-structured viruses in the Norwalk virus group. *J. Virol.* 68:5982-5990, 1994.

- 16.26 Yamazaki K, Oseto M, Seto Y, et al. Reverse transcription-polymerase chain reaction detection and sequence analysis of small round-structured viruses in Japan. *Arch. Virol. Suppl.* 12:271-276, 1996.
- 16.27 Roche Molecular Biochemicals LightCycler Operator's Manual, version 3.5. Roche Diagnostics GmbH. Roche Applied Science. 68298 Mannheim, Germany. October, 2000.
- 16.28 ROpure Infinity Premier Model Reverse Osmosis System, LT901X4. Barnstead/Thermolyne Corporation, 1997.
- 16.29 60 Liter Infinity Storage Reservoir, LT902X. Barnstead/Thermolyne Corporation, 1997.
- 16.30 Nanopure Infinity UV/UF System, LT899X. Barnstead/Thermolyne Corporation, 1998.
- 16.31 Procedure for Evaluation Accuracy and Precision of Rainin Pipettes, AB-15 R2. Rainin Instrument Company, Inc. 1994-1997.
- 16.32 Pipette Care and Maintenance, AB-14 R3. Rainin Instrument Company, Inc. 1994-1997.
- 16.33 *Roche Applied Science MagNA Pure LC Operators Manual, version 3.0.* Roche Diagnostics GmbH, Roche Applied Science. 68298 Mannheim, Germany. Version 3.0, 2004.
- 16.34 ABI Prism 7000 Sequence Detection System. User Guide. Applied Biosystems 850 Lincoln Centre Drive, Foster City, California. 2003.

## 17. Appendix

- 17.1 RNA Extraction Bench Work Sheet
- 17.2 LightCycler RT-PCR Amplification Bench Work Sheet
- 17.3 ABI 7000 RT-PCR Amplification Bench Work Sheet
- 17.4 Master Mix Calculations
- 17.5 Sequences
- 17.6 Instructions for the preparation and storage of primers
- 17.7 Instructions for the preparation and storage of probes
- 17.8 Instruction Manuals
- 17.9 PCR Etiquette
- 17.10 Wipe Test
- 17.11 LightCycler Maintenance Log
- 17.12 MagNA Pure LC Instrument Maintenance Log
- 17.13 MagNA Pure LC Instrument O-Ring Maintenance Log
- 17.14 ABI 7000 Maintenance Log
- 17.15 Report Template

17.1

**RNA EXTRACTION BENCH WORK SHEET**  
**MagNA Pure RNA Extraction Sample Cartridge Specimen Map**  
**NOROVIRUS**

Date: \_\_\_\_\_ Laboratorian: \_\_\_\_\_

Specimen #6	Specimen #5	Specimen #4	Specimen #3	Specimen #2	Specimen #1	Negative Extraction	Positive Extraction
Specimen #14	Specimen #13	Specimen #12	Specimen #11	Specimen #10	Specimen #9	Specimen #8	Specimen #7
Specimen #22	Specimen #21	Specimen #20	Specimen #19	Specimen #18	Specimen #17	Specimen #16	Specimen #15

MagNA Pure Total NA Kit	Lot#:	Exp. Date:
-------------------------	-------	------------

**Qiagen Manual DNA Extraction**

Date: \_\_\_\_\_ Laboratorian : \_\_\_\_\_

Qiagen Kit
Lot#
Exp. Date

**Lot # QC**

	Lot Number	Expiration Date
STE Neg Ctrl		
Norovirus Pos. Ctrl		
Kan RNA Ctrl		

17.2

**BENCH WORK SHEET**  
**Norovirus Virus LightCycle Real-time RT-PCR Assay**

LightCycler File		LightCycler Used	Self Check
Performed by:		A    B    C    D	PASS
Date Tested			ERROR

**LightCycler Carousel Specimen Map**

	SAMPLE	GENE	RESULTS		SAMPLE	GENE	RESULTS
1				17			
2				18			
3				19			
4				20			
5				21			
6				22			
7				23			
8				24			
9				25			
10				26			
11				27			
12				28			
13				29			
14				30			
15				31			
16				32			

	LOT#	EXPIRATION	LOT#	EXPIRATION
RNA MASTER Kit			Norovirus PROBES G1a, G1b, G2	
UNG			Kan-PRIMERS	
Norovirus PRIMERS G1 and G2 Forward and Reverse			Kan-PROBE	

17.3

**ABI 7000 RT-PCR Amplification Bench Work Sheet**  
**Norovirus**

ABI Prism 7000: A <input type="checkbox"/> B <input type="checkbox"/> C <input type="checkbox"/>			FILE NAME					
PERFORMED BY:			DATE:					
	H	G	F	E	D	C	B	A
Specimens A1-H1	#6	#5	#4	#3	#2	#1	Negative	G1/G2 Positive
G1								
G2								
Kan								
Specimen A2-H2	#14	#13	#12	#11	#10	#9	#8	#7
G1								
G2								
Kan								
Specimens A3-H3	#22	#21	#20	#19	#18	#17	#16	#15
G1								
G2								
Kan								

Notch

	LOT#	EXPIRATION	LOT#	EXPIRATION
RNA MASTER Kit			Norovirus PROBES G1a, G1b, G2	
UNG			Kan-PRIMERS	
Norovirus PRIMERS G1 and G2 Forward and Reverse			Kan-PROBE	



17.4

### Norovirus G1 Master Mix Calculations Number of Reactions

Reagent	1	2	3	4	5	6	7	8	9	10	11	12	13
PCR Grade Water	5.2	10.4	15.6	20.8	26	31.2	36.4	41.6	46.8	52	57.2	62.4	67.6
Primer Forward-16 um	0.5	1.0	1.5	2.0	2.5	3.0	3.5	4.0	4.5	5.0	5.5	6.0	6.5
Primer Reverse-16um	0.5	1.0	1.5	2.0	2.5	3.0	3.5	4.0	4.5	5.0	5.5	6.0	6.5
Probe 1a-600 pm	0.5	1.0	1.5	2.0	2.5	3.0	3.5	4.0	4.5	5.0	5.5	6.0	6.5
Probe 1b-200 pm	0.5	1.0	1.5	2.0	2.5	3.0	3.5	4.0	4.5	5.0	5.5	6.0	6.5
25 mM MgCl2	3.2	6.4	9.6	12.8	16.0	19.2	22.4	25.6	28.8	32.0	35.2	38.4	41.6
Reagent Mix-Cap#2	4.0	8.0	12.0	16.0	20.0	24.0	28.0	32.0	36.0	40.0	44.0	48.0	52.0
Enzyme-Cap #1	0.4	0.8	1.2	1.6	2.0	2.4	2.8	3.2	3.6	4.0	4.4	4.8	5.2
UNG	0.2	0.4	0.6	0.8	1.0	1.2	1.4	1.6	1.8	2.0	2.2	2.4	2.6
Total Volume	15	30	45	60	75	90	105	120	135	150	165	180	195

### Norovirus G2 Master Mix Calculations Number of Reactions

Reagent	1	2	3	4	5	6	7	8	9	10	11	12	13
PCR Grade Water	5.7	11.4	17.1	22.8	28.5	34.2	39.9	45.6	51.3	57	62.7	68.4	74.1
Primer Forward-16 um	0.5	1.0	1.5	2.0	2.5	3.0	3.5	4.0	4.5	5.0	5.5	6.0	6.5
Primer Reverse 16 um	0.5	1.0	1.5	2.0	2.5	3.0	3.5	4.0	4.5	5.0	5.5	6.0	6.5
Probe 2- 200 pm	0.5	1.0	1.5	2.0	2.5	3.0	3.5	4.0	4.5	5.0	5.5	6.0	6.5
25 mM MgCl2	3.2	6.4	9.6	12.8	16.0	19.2	22.4	25.6	28.8	32.0	35.2	38.4	41.6
Reagent Mix-Cap#2	4.0	8.0	12.0	16.0	20.0	24.0	28.0	32.0	36.0	40.0	44.0	48.0	52.0
Enzyme-Cap #1	0.4	0.8	1.2	1.6	2.0	2.4	2.8	3.2	3.6	4.0	4.4	4.8	5.2
UNG	0.2	0.4	0.6	0.8	1.0	1.2	1.4	1.6	1.8	2.0	2.2	2.4	2.6
Total Volume	15	30	45	60	75	90	105	120	135	150	165	180	195

### Kanamycin Master Mix Calculations Number of Reactions

Reagent	1	2	3	4	5	6	7	8	9	10	11	12	13
PCR Grade Water	5.7	11.4	17.1	22.8	28.5	34.2	39.9	45.6	51.3	57	62.7	68.4	74.1
Primer Forward-16 um	0.5	1.0	1.5	2.0	2.5	3.0	3.5	4.0	4.5	5.0	5.5	6.0	6.5
Primer Reverse-16 um	0.5	1.0	1.5	2.0	2.5	3.0	3.5	4.0	4.5	5.0	5.5	6.0	6.5
Probe- 200 pm	0.5	1.0	1.5	2.0	2.5	3.0	3.5	4.0	4.5	5.0	5.5	6.0	6.5
25 mM MgCl2	3.2	6.4	9.6	12.8	16.0	19.2	22.4	25.6	28.8	32.0	35.2	38.4	41.6
Reagent Mix-Cap #2	4.0	8.0	12.0	16.0	20.0	24.0	28.0	32.0	36.0	40.0	44.0	48.0	52.0
Enzyme-Cap #1	0.4	0.8	1.2	1.6	2.0	2.4	2.8	3.2	3.6	4.0	4.4	4.8	5.2
UNG	0.2	0.4	0.6	0.8	1.0	1.2	1.4	1.6	1.8	2.0	2.2	2.4	2.6
Total Volume	15	30	45	60	75	90	105	120	135	150	165	180	195

17.5

Primer and Probe Sequences

<b>Norovirus G1 Forward Primer</b>	5' CGYTGGATGCGNTTYCATGA 3'
<b>Norovirus G1 Reverse Primer</b>	5' CTTAGACGCCATCATCATTYAC 3'
<b>Norovirus G2 Forward Primer</b>	5' CARGARBCNATGTTYAGRTGGATGAG 3'
<b>Norovirus G2 Reverse Primer</b>	5' TCGACGCCATCTTCATTCACA 3'
<b>Norovirus Ring 1a TaqMan FAM-labeled Probe</b>	5' FAM-AGATYGCGATCYCCTGTCCA-TAMRA 3'
<b>Norovirus Ring 1b TaqMan FAM-labeled Probe</b>	5' FAM-AGATCGCGGTCTCCTGTCCA-TAMRA 3'
<b>Norovirus Ring 2 TaqMan FAM-labeled Probe</b>	5' FAM-TGGGAGGGCGATCGCAATCT-TAMRA 3'
<b>Kanamycin Forward Primer</b>	5' TCAACGGGAAACGTCTTGCT 3'
<b>Kanamycin Reverse Primer</b>	5' CGCGAGCCCATTTATACCCATAT 3'
<b>Kanamycin TaqMan FAM-labeled Probe</b>	5' FAM CCGCGATTAAATTC-MGR 3'

## 17.6 Instructions for the preparation and storage of primers

### 17.6.1 Molarities used for the Norovirus (G1 and G2) and Kanamycin PCR Primers

STOCK	MOLARITY
CONCENTRATED	100 $\mu\text{M}$
WORKING	16 $\mu\text{M}$

### 17.6.2 Prepare and store the primers according to the following directions:

17.6.2.1 Locate the  $\eta\text{Mol}$  value for each primer on the quality assurance document

Example: 67.6  $\eta\text{Mole}$

17.6.2.2 Multiply this value by ten (10). This is the amount of water that you need to add to the vial to achieve a 100  $\mu\text{M}$  concentrated stock.

Example: 676  $\mu\text{l}$  water

17.6.2.3 Aliquot this concentrated 100  $\mu\text{M}$  stock into a reasonable number of tubes. Ideally you will only thaw the stock once to make a working concentration.

17.6.2.4 The working concentration is 16  $\mu\text{M}$ . To prepare the working concentration:

***Add 10  $\mu\text{l}$  of the concentrated stock to 52.50  $\mu\text{l}$  water***

17.6.2.5 Aliquot the working stock into labeled tubes. Place one at 4°C and the rest at -20°C. Do not freeze/thaw working stock.

## 17.7 Instructions for the preparation and storage of the probes

### 17.7.1 Molarities used for the PCR probes

PROBE	CONCENTRATED	WORKING
G1 (Ring 1a TP)	6000 pMole	600 pMole
G1 (Ring 1b TP)	6000 pMole	200 pMole
G2 (Ring2TP)	6000 pMole	200 pMole
Kanamycin	6000 pMole	200 pMole

### 17.7.2 Preparation and storage of the probes

- 17.7.2.1 Check which pMol was ordered  
Usually we order 6000 pMole already suspended in buffer.
- 17.7.2.2 Dilute the probe in water to achieve a 200 pMole concentration for Ring 1b TP, Ring 2TP, and the Kanamycin  
1  $\mu$ l of 6000 pMole into 29  $\mu$ l water
- 17.7.2.3 Dilute Ring 1aTP to achieve a 600 pMole concentration  
1  $\mu$ l of 6000 pMole into 9  $\mu$ l water
- 17.7.2.4 Aliquot both the concentrated and working stock of probe.
- 17.7.2.5 Place on tube of working probe at 4°C and the rest of the tubes at -20°C.

17.8 Instruction Manuals

- 17.8.1 QIAamp Viral RNA Mini Kit Handbook
- 17.8.2 Roche MagNA Pure LC Nucleic Acid Isolation Kit I
- 17.8.3 LightCycler RNA Amplification kit HybProbe

...ding to the next phase  
...before starting RT-PCR  
...run itself should also

...titles of the same lot.

...inding Buffer touch yo  
...sh the affected area  
...gent, dilute the spill w/

...dine thiocyanate, to m  
...produce a highly toxic

...oratory procedures.

...protection when han

...onuclease. We recom  
...remove aliquots from  
...gents.

...handling steps. To avo  
...the literature (1,2,3,4).

...eral, state, and local re

...est from the local Roc

...che Applied Scier.

For general laboratory use.  
FOR *IN VITRO* USE ONLY.

# MagNA Pure LC Total Nucleic Acid Isolation Kit

For isolation of total nucleic acid from mammalian serum, plasma, and whole blood, using the MagNA Pure LC Instrument

**Cat. No. 03 038 505 001**  
192 isolations

Store the kit at +15 to +25°C

If properly stored, all kit components are stable through the expiration date printed on the label.

***Instruction Manual***  
Version September 2004



### 3.1 Before you begin, continued

#### Associated Magna Pure LC Protocols

Three different MagNA Pure LC purification protocols are available. Use the following table to decide which is best for your samples:

Protocol name	Application
<b>Total NA Serum_Plasma_Blood</b>	<ul style="list-style-type: none"> <li>fully automated</li> <li>sample volume: 50 µl to 200 µl</li> <li>elution volume: 100 µl</li> </ul>
<b>Total NA Variable_elution_volume</b>	<ul style="list-style-type: none"> <li>fully automated</li> <li>sample volume: 50 µl to 200 µl</li> <li>elution volume: 50-100 µl</li> </ul>
<b>Total NA External_lysis</b>	<ul style="list-style-type: none"> <li>manual sample lysis step outside the MagNA Pure LC Instrument</li> <li>allows to physically separate the lysis step from the purification step and to load inactivated sample material to the MagNA Pure LC Instrument</li> <li>sample volume: 50 µl to 200 µl</li> <li>elution volume: 50-100 µl</li> </ul>

#### Note:

- As the sensitivity and titer of potential pathogens in the sample material varies, the operator has to optimize pathogen inactivation by the lysis buffer or take appropriate measures according to local safety regulations.
- When using whole blood, e.g., unseparated EDTA-blood as sample material it is recommended to use always the maximum possible elution volume of 100 µl due to the high total nucleic acid content especially of high molecular weight DNA in the eluate.

Please refer to the table below for handling and preparation of the working solutions:

#### Notes:

- All other solutions are ready-to-use.
- Buffers are clear, and should not be used when precipitates have formed. Warm solutions at +15 to +25°C until precipitates have dissolved before use, if reagents used outside the recommended temperature range the optimal kit performance might not be achieved.
- It is not recommended to store the Proteinase K and the MGP suspension in Reagent Tubs (tubs 4 and 5). Use only the amount needed for your sample number.
- All other reagents remaining in the reagent tubs after completion of the run can be used for the next run if performed on the same day. Longer storage periods are not recommended.

#### Handling and Preparation of Solutions

### 3. Procedure

#### 3.1 Before You Begin

Please read carefully section 1.2 Precautions before starting the procedure.

- Standard laboratory equipment
- Pipettes and nuclease-free aerosol-preventive tips to predispense samples into Sample Cartridge.
- Centrifuge and suitable nuclease-free reaction tubes
- Vortex mixer.

#### Assay Time

Procedure	Time
<b>Step 1:</b> Setup of the MagNA Pure LC Instrument	approx. 15 min
<b>Step 2:</b> Automated nucleic acid purification: 1 - 16 samples 17 - 32 samples	45 min 85 min
Total hands on time	approx. 15 min

To obtain optimal results in downstream procedures, especially in LightCycler PCR, the purification protocols should be used only according to the parameters as specified in Table 1 below. Using other combinations will result in suboptimal yields of nucleic acids.

#### Sample Material

Table 1: Possible combinations of sample and elution volume.

Sample Material	Sample Volume	Elution Volume	Comments
Plasma	100 to 200 µl	50 to 100 µl	
Serum	100 to 200 µl	50 to 100 µl	
Whole Blood (EDTA)	100 µl	100 µl	WBC count of sample has to be < 1 × 10 <sup>6</sup> , as expected for healthy humans.

Note: All protocols were established with human serum, plasma, and blood. If studying other mammals, possible differences in the blood cell concentration between the species should be taken into account. Therefore, for samples from other species, it might be necessary to adjust the blood cell concentration (determined by a cell counting device) before beginning with the experiment.

The kit is designed to process up to 192 samples in batches of 32. If you process fewer than 32 samples at a time, some reagent will be wasted and the remaining reagent will not be enough to process 192 samples. In order to save reagent buffers it is recommended to perform at least 8 purifications in one run or a multiple of eight. All buffers are clear. Do not use a buffer if it contains a precipitate.

**Note:** Before using them, warm the solutions at 15-25°C until precipitates have dissolved. If you use the reagents at temperatures outside the recommended range, the kit may not work well. The Lysis/Binding Buffer contains a blue component needed for clot detection.

Bottle/ Color of cap	Label	Contents / Function
1 black	Wash Buffer I	<ul style="list-style-type: none"> <li>• 2 bottles with 100 ml each</li> <li>• for removing PCR inhibitors</li> </ul>
2 blue	Wash Buffer II	<ul style="list-style-type: none"> <li>• 1 bottle with 100 ml</li> <li>• for removing salts, proteins etc.</li> </ul>
3 red	Wash Buffer III	<ul style="list-style-type: none"> <li>• 2 bottles with 100 ml each</li> <li>• for removing salts etc.</li> </ul>
4 green	Lysis/Binding Buffer	<ul style="list-style-type: none"> <li>• 1 bottle with 100 ml</li> <li>• for cell lysis and binding of total nucleic acid</li> </ul>
5 pink	Proteinase K	<ul style="list-style-type: none"> <li>• 6 glass vials with lyophilizate</li> <li>• for digestion of proteins</li> </ul>
6 caramel	Magnetic Glass Particles (MGPs) Suspension	<ul style="list-style-type: none"> <li>• 6 glass vials with 6 ml each</li> <li>• for binding of total nucleic acid</li> </ul>
7 yellow	Elution Buffer	<ul style="list-style-type: none"> <li>• 1 bottle with 100 ml</li> <li>• for elution of pure total nucleic acid</li> </ul>

1.4 Kit Storage and Stability

- The kit is stable through the expiration date printed on the label if all components are stored properly at +15 to +25°C.
- The kit is shipped at +15 to +25°C.
- Store kit components as described in the following table:

Component	Storage
Proteinase K reconstituted	<ul style="list-style-type: none"> <li>• stable at 2-8°C for 4 weeks</li> <li>• stable at -15 to -25°C for up to 1 year</li> </ul>
All other kit components	+15 to +25°C

2. Introduction

2.1 Product Overview

**Product Description**

MagnaNA Pure LC Total Nucleic Acid Isolation Kit should be used with the MagnaNA Pure LC Instrument to isolate highly purified total nucleic acid from a variety of sample materials (mammalian serum, plasma, unseparated whole blood) on the MagnaNA Pure LC Instrument. The kit together with the MagnaNA Pure LC Instrument allows the automation of pure total nucleic acid from 1-32 samples within approx. 60-110 min (with manual preparation steps). The isolated total nucleic acid can be eluted in various volumes from 50-100 µl and is of high quality and integrity suitable for highly sensitive and quantitative PCR and RT-PCR analysis on the LightCycler System, as well as standard block cyler PCR and all other typical downstream applications.

**Test Principle**

The purification of total nucleic acid is based on magnetic bead technology and is divided into the seven basic steps described below.

Step	Description
1	Addition of Lysis/Binding Buffer results in a complete lysis of the sample by denaturation of proteins. DNA and RNA is released and simultaneously stabilized.
2	Proteinase K is added to the samples and digest of proteins from the sample
3	Total nucleic acid binds to the silica surface of the added MGPs due to the chemical conditions and the high ionic strength of the Lysis/Binding Buffer.
4	Wash Buffer I removes unbound substances like denatured proteins (nucleases, cellular membranes, etc. and PCR inhibitors like heparin or hemoglobin.
5	Wash Buffer II further removes impurities (cellular debris) and reduces the chemical salt concentration.
6	Wash Buffer III further removes impurities and reduces the salt concentration
7	Purified total nucleic acid is eluted at elevated temperature.

**Application**

**For general laboratory use.** The MagnaNA Pure LC Total Nucleic Acid Isolation Kit is designed for the purification of total nucleic acids from various scientific sample materials (mammalian serum, plasma, whole blood) on the MagnaNA Pure LC Instrument. Purified total nucleic acid is suitable for highly sensitive and quantitative PCR and RT-PCR reactions on the LightCycler System, as well as for standard block cyler PCR reactions.

**Quality Control**

The kit is function-tested by isolation of viral nucleic acid from Hepatitis A-positivity Parvo B19-positive human reference material using the standard purification protocol (Total NA Serum, Plasma, Blood). Purified viral nucleic acid is detected by qualitative, on-line PCR using both a HAV specific and a Parvo B19-specific assay established for the LightCycler Instrument.



Solution	Preparation	Storage/stability
Proteinase K	For 32 reactions, dissolve one bottle Proteinase K (Vial 5, pink cap) by adding 5.0 ml Elution Buffer (Vial 7, yellow cap).	2-8°C (up to 4 weeks) or -15 to -25°C (up to 12 months)
MGP suspension	<ul style="list-style-type: none"> <li>For 32 isolations, one bottle of MGP suspension (Vial 6, caramel-colored cap) is needed.</li> <li>The MGP suspension must be mixed thoroughly. Vortex immediately before use to produce a homogeneous suspension.</li> <li>It is very important to only fill the MGPs into the respective Reagent Tub when all other reagents, all disposable plastics, and the samples are in place on the MagNA Pure LC Instrument.</li> <li>For best results, add the MGPs to the instrument just before starting the run (to minimize sedimentation). Always use the exact amount of MGPs recommended by the software.</li> </ul>	<ul style="list-style-type: none"> <li>Do not store in Reagent Tub!</li> <li>Do not leave the MGP solution uncovered in the bottle or in the reagent tub, as evaporation of alcohol might lead to suboptimal purification!</li> </ul>

No preparation is necessary. Transfer 50 µl to 200 µl of sample material (for an overview see table 1) directly into the Sample Cartridge and proceed as described in section 3.4.

#### Total NA External Lysis Protocol

Step	Action
1	Transfer 50 µl to 200 µl of sample material (for an overview see Table 1) into a suitable vial, e.g., the Sample Cartridge.
2	Add 300 µl Lysis/Binding Buffer (Bottle 4, green cap) to each vial
3	Mix the samples thoroughly by pipetting.
4	<ul style="list-style-type: none"> <li>Transfer the lysed samples (350 µl to 500 µl) into the Sample Cartridge.</li> <li>Place the Sample Cartridge into the MagNA Pure LC Instrument.</li> </ul>
5	Proceed as described in section 3.2.

#### Notes

- The following procedure is designed to process 32 samples at the same time. If it is not possible to process all samples at the same time, the volumes of all solutions should be reduced accordingly (see the Start Information Screen of the MagNA Pure LC Instrument).
- The software automatically calculates the volumes of all reagents needed for each run and guides you through the set-up.
- You cannot start the instrument unless the interlock for securing Sample Cartridge is closed.

- Turn on instrument and computer then start the MagNA Pure LC Software. Select appropriate protocol: **Total NA Serum\_Plasma\_Blood**, **Total NA Variable\_elution\_volume**, or **Total NA External\_lys**.
- Follow the guidance of the software program. Type in sample number, sample volume, and sample names. The software will calculate the amounts of disposable plastics and reagents needed for a run, depending on the number of samples to be processed.

**Note:** When using the Total NA External\_lys protocol, type in the volume of the primary sample, not the volume of the primary sample.

#### Filling of the Reagent Tubs

Before starting the isolation procedure, all Reagent Tubs of the system must be filled with the required amount of reagents (warmed up to room temperature). Fill each Reagent Tub with the volume listed on the Start Information Screen, then cap it with the Tub Lid to prevent evaporation of reagents.

#### Notes:

- If you are not starting the run immediately, we recommend closing the Reagent Tub with the Tub Lid Seal to prevent evaporation of the reagents. But even when closed, Reagent Tubs are not suitable for long-term storage of reagents.
- It is not recommended to store the Proteinase K and the MGP suspension in the Reagent Tubs (tubs 4 and 5). Other reagents remaining in the Reagent Tubs after completion of a run may be used for the next run if performed on the same day.
- We recommend loading the MGPs just before a run to keep them from sedimenting. Always use the exact amount of MGPs as indicated by the software.

#### Set-up Reagent Tubs on Stage

#### Loading the Samples

The software will show how to position each Reagent Tub on the stage (see Start Information screen). A colored "Positioning Frame" (Cat. No. 12 256 134 001) that can be placed on the Reagent Tub Rack to aid correct loading of reagents is available for purchase.

Transfer the Sample Cartridge containing the lysate to the MagNA Pure LC Instrument stage.

**Run**

Confirm correct set-up of the instrument stage on the Start Information Screen by mouse clicking. Start the isolation procedure. The system will automatically dispense all reagents and process the samples.

The table below shows the steps in the automated nucleic acid isolation protocol of the MagNA Pure LC Instrument.

**Note:** All steps are automatically performed by the MagNA Pure LC Instrument. After completion of the run, the Result Screen will appear.

Step	Action performed automatically by the MagNA Pure LC System:
(0)	Dispense all necessary reagents into the Processing Cartridge.
(0)	Dispense Elution Buffer into the Elution Cartridge (Heating Block).
1	<b>Total NA Serum, Plasma, Blood and Variable_elution_volume protocol:</b> Mix 300 µl Lysis/Binding Buffer with the samples. <b>Total NA External_Lysis protocol:</b> Mix the lysed samples.
2	Transfer into 100 µl Proteinase K solution, mix.
3	Transfer into 150 µl MGP suspension, mix, incubate, separate particles.
4	Transfer MGPs into 850 µl Wash Buffer I, mix, separate particles.
5	Transfer MGPs into 450 µl Wash Buffer II, mix, separate particles.
6	Transfer MGPs into 450 µl Wash Buffer III, mix, separate particles.
7	Transfer MGPs into Elution Buffer (Heating Block), mix, incubate, elute total nucleic acid in 50-100 µl Elution Buffer.
8	Transfer the eluate into the Storage Cartridge (Cooling Block).

**Storage of the Eluates**

The eluted, pure total nucleic acid will be stored on the cooling block for further processing. For long term storage cover the wells of the Sample Cartridge with a Cartridge Seal and store the total nucleic acid at -70 °C or lower. It is best to store the eluates in aliquots, so the preparation will not have to be repeatedly frozen and thawed.

**Note:** The Elution Buffer used in the MagNA Pure LC Total Nucleic Acid Isolation Kit - Large Volume contains stabilizing components that interfere with standard OD<sub>260</sub> nm measurements.

**Post Elution**

The MagNA Pure LC Instrument can help set up PCR reactions by pipetting aliquot total nucleic acid eluates and PCR master mixes into either LightCycler capillaries, standard PCR tubes or plates. (See the MagNA Pure LC Operator's Manual for recommended plates.) For post-elution procedures, you can place LightCycler capillaries in the removable MagNA Pure LC Cooling Block, LC Centrifuge Adapters or MagNA Pure LC Cooling Block, LC Sample Carousel. You can program the post-elution steps either before you perform the isolation procedure or after it is complete.

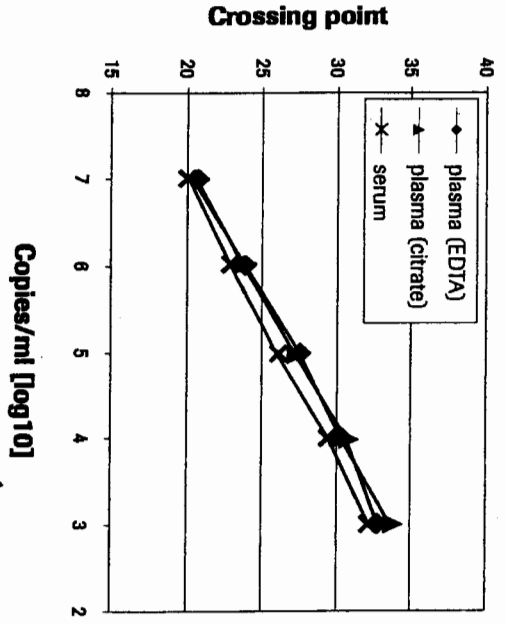
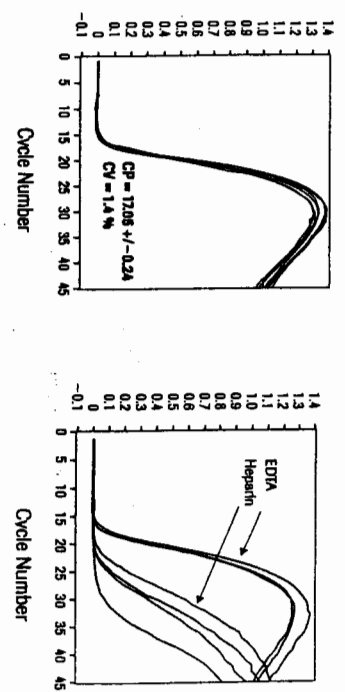

**Fig. 1: LightCycler analysis of Hepatitis A virus-positive, human EDTA-plasma, citrate plasma, and serum samples after purification with the MAGNA Pure LC Total Nucleic Acid Isolation Kit.**

Hepatitis A virus was serially 10-fold diluted to the indicated virus concentrations in the indicated human sample materials. 200 µl of each sample was purified automatically using the MAGNA Pure LC Total Nucleic Acid Isolation Kit in 2-fold replicates. Analysis was done using HAV-specific, quantitative RT-PCR on the LightCycler instrument.

**Anticoagulants - Removal of Inhibitors**

Different sample matrices (human EDTA-plasma, citrate plasma, serum, EDTA-blood heparinized blood) positive for viral DNA and viral RNA were subjected to total nucleic acid isolation using the standard isolation protocol. No PCR inhibition was observed when analysing the eluates in the LightCycler instrument (for a typical example see 2).



**Fig. 2: LightCycler analysis of Parvo B19 virus-positive samples coagulated EDTA and heparin after purification with the MAGNA Pure LC Total Nucleic Acid Isolation Kit (A) and a reference method (B).**

Using the MAGNA Pure LC Isolation Kit there was no difference observed between purification from EDTA blood samples and heparinized blood samples, whereas with method B inhibitory components from heparinized blood could not be completely removed.

96 plasma samples spiked with Parvo B19 at a concentration of  $5 \times 10^6$  copies/ml 96 Parvo B19-negative plasma samples were purified by the MAGNA Pure LC Total Nucleic Acid Isolation Kit. The orientation of the samples in the sample cartridge chosen that every other well was filled with an unspiked, Parvo B19-negative plasma sample. Using a highly sensitive Parvo B19-specific LightCycler assay no signal was observed in all of the unspiked samples, whereas in the Parvo B19-positive sample expected signal was observed.

30-fold replicates of a plasma sample positive for viral RNA were purified using the MAGNA Pure LC Total Nucleic Acid Isolation Kit and the eluted nucleic acids were analysed by the LightCycler instrument. The coefficient of variance (CV %) calculated corresponding crossing points was observed to be < 2 %.

6 plasma samples positive for viral RNA were subjected to the standard total nucleic acid isolation protocol in 4 independent runs. Eluates were analysed by the LightCycler instrument. The coefficient of variance (CV %) calculated for corresponding crossing points was observed to be < 2 %.

Troubleshooting

Problem	Possible cause	Recommendation
Clumping of beads	Too much sample material MGPs were magnetized prior to use	Reduce amount of sample material to the values recommended in the section "sample material" Avoid contact of the MGPs with magnets prior to the first use.
Nucleic Acid is degraded	Storage of samples was not appropriate.	Use fresh or frozen samples, avoid the use of samples that were stored at room temperature.
Unclear UV spectrum	The Elution Buffer used in the MagNA Pure LC Total Nucleic Acid Isolation Kit contains stabilizing components that interfere with standard OD <sub>260 nm</sub> measurements.	
Unexpected amount of eluate	Wrong elution volume has been set	Confirm correct setting of elution volume as indicated in the pack insert.
Eluates show slightly red color	Minimal abrasion from magnetic particles.	Centrifuge at low g-values (approx. 1000 rpm) to remove fines. <b>Note: The red color does not negatively effect LightCycler PCR.</b>

5.2 Ordering Information

Roche Applied Science offers a large selection of reagents and systems for life science research. For a complete overview of related products and manuals, please visit and bookmark <http://www.roche-applied-science.com> and our Special Interest Sites including:

- the MagNA Pure Family for automated nucleic acid isolation: <http://www.magnapure.com>
- the LightCycler System family for real-time, online PCR: <http://www.lightcycler-online.com>
- PCR - Innovative Tools for Amplification: <http://www.roche-applied-science.com/sis/amplification>

Product	Pack Size	Cat. No.
<b>Instruments and Accessories</b>		
MagNA Pure LC Instrument	1 instrument plus accessories	12 238 931 001
LightCycler 2.0 Instrument	1 instrument plus accessories	03 531 414 201
LightCycler 1.5 Instrument *available October 2004	1 instrument plus accessories	04 484 495 001
MagNA Pure LC Cooling Block, LC Centrifuge Adapters	1 cooling block with 32 LightCycler Centrifuge Adapters	12 190 664 001
MagNA Pure LC Cooling Block, LC Sample Carousel	1 cooling block	12 189 704 001
MagNA Pure LC Cooling Block, 96-well PCR Plate	1 cooling block	12 189 674 001
MagNA Pure LC Cooling Block, Reaction Tubes	1 cooling block	12 189 666 001
LightCycler Carousel Centrifuge 2.0	1 centrifuge plus rotor and bucket (230 V)	03 709 507 001
	1 centrifuge plus rotor and bucket (115 V)	03 709 507 001

5.2 Ordering Information, continued

of reagents and systems for life science products and manuals, please visit and on and our Special Interest Sites includ-

ic acid isolation:

online PCR:

amplification

Pack Size	Cat. No.
<b>Accessories</b>	
instrument plus accessories	12 236 931 001
instrument plus accessories	03 531 414 201
instrument plus accessories	04 484 495 001
cooling block with 32 rotCycler Centrifuge Adapters	12 190 664 001
1 cooling block	12 189 704 001
1 cooling block	12 189 674 001
1 cooling block	12 189 666 001
refuge plus rotor and bucket (230 V)	03 709 507 001
refuge plus rotor and bucket (115 V)	03 709 507 001

Product	Pack Size	Cat. No.
<b>MagNA Pure LC Kits for DNA Isolation</b>		
MagNA Pure LC DNA Isolation Kit I <sup>1)</sup>	1 kit 192 reactions	03 003 990 001
MagNA Pure LC DNA Isolation Kit II (Tissue) <sup>1)</sup>	1 kit 192 reactions	03 186 229 001
MagNA Pure LC DNA Isolation Kit III (Bacteria, Fungi) <sup>1)</sup>	1 kit 192 reactions	03 264 785 001
MagNA Pure LC DNA Isolation Kit - Large Volume <sup>1)</sup>	1 kit 96 isolations from 1 ml blood 192 isolations from 300-500 µl blood 288 isolations from 20-200 µl blood 192 isolations from blood cells 192 isolations from 5 x 10 <sup>6</sup> culture cells	03 310 515 001
MagNA Pure LC DNA Isolation Kit I - Lysis/Binding Buffer Refill	70 ml	03 246 752 001
<b>MagNA Pure LC Kits for Total Nucleic Acid Isolation</b>		
MagNA Pure LC Total Nucleic Acid Isolation Kit <sup>1)</sup>	1 kit 192 reactions	03 038 505 001
MagNA Pure LC Total Nucleic Acid Isolation Kit - Large Volume <sup>1)</sup>	1 kit 192 reactions	03 264 793 001
MagNA Pure LC Total Nucleic Acid Isolation Kit I - Lysis/Binding Buffer Refill	70 ml	03 246 779 001
<b>MagNA Pure LC Kits for total RNA/mRNA Isolation</b>		
MagNA Pure LC RNA Isolation Kit - High Performance <sup>1)</sup>	1 kit 192 reactions	03 542 394 001
MagNA Pure LC RNA Isolation Kit III (Tissue) <sup>1)</sup>	1 kit 192 reactions	03 330 591 001
MagNA Pure LC mRNA Isolation Kit I (Blood, Blood Cells, Culture Cells) <sup>1)</sup>	1 kit 192 reactions	03 004 015 001
MagNA Pure LC mRNA Isolation Kit II (Tissue) <sup>1)</sup>	1 kit 192 reactions	03 172 672 001
MagNA Pure LC mRNA HS Kit <sup>1)</sup>	1 kit 192 reactions	03 267 393 001
MagNA Pure LC mRNA Isolation Kit I - Lysis Buffer Refill	70 ml	03 246 744 001

**Notice to Purchaser**

The purchase of the **Magna Pure LC Total Nucleic Acid Isolation Kit** does not convey any licenses or other rights for the performance of PCR.

1) The purchase of this product does not convey any licenses or other rights for the performance of PCR.

**LightCycler, Magna Pure** and **Magna Lyser** are trademarks of a member of the Roche group.

The technology used for the **LightCycler** system is licensed from **Idaho Technology Inc.**, Salt Lake City, UT, USA.

0904.03043444®

**[www.roche-applied-science.com](http://www.roche-applied-science.com)**

to order, solve technical queries, find product information,  
or contact your local sales representative.

**[www.roche-applied-science.com/pack-insert/03038505001a.pdf](http://www.roche-applied-science.com/pack-insert/03038505001a.pdf)**

Please visit our new Online Technical Support Site at  
[www.roche-applied-science.com/support](http://www.roche-applied-science.com/support)



Roche Diagnostics GmbH  
Roche Applied Science  
Nonnenwald 2  
82372 Penzberg  
Germany

*Roche Applied Science*

For general laboratory use.  
FOR *IN VITRO* USE ONLY.



*Roche Applied Science*

---

**LightCycler<sup>®</sup> RNA  
Amplification Kit HybProbe**

---

**Version December 2004**

Kit for One-Step RT-PCR using the LightCycler System

**Cat. No. 12 015 145 001**

Kit for 96 reactions

**Store the kit at -15 to -25°C**

# Table of Contents

3	What this Product Does
3	Number of Tests
3	Kit Contents
3	Storage and Stability
4	Additional Equipment and Reagents Required
4	Application
5	How to Use this Product
6	Before You Begin
6	Sample Material
6	Primers
6	5'-3' Probe Probes
6	MgCl <sub>2</sub>
7	Negative Control
7	NA Contamination Control
8	Procedure
8	LightCycler Protocol
8	Fluorescence and Run Setup Parameters
10	Preparation of the PCR Mix
11	Related Procedures
13	Color Compensation
13	Prevention of Carry-Over Contamination
14	Results
15	Troubleshooting
17	Additional Information on this Product
17	How this Product Works
17	Background Information
18	References
18	Quality Control
19	Supplementary Information
19	Conventions
19	Changes to Previous Version
19	Ordering Information
21	Disclaimer of License
21	Trademarks

## 1. What this Product Does

**Number of Tests** The kit is designed for 96 reactions with a final reaction volume of 20 µl each.

Vial/Cap	Label	Contents / Function
1	red cap	LightCycler RT-PCR Enzyme Mix • 2x 20 µl • enzyme mix for RT-PCR
2	red cap	LightCycler RT-PCR Reaction Mix Hyb-Probe, 5x conc. • 3x 128 µl • reaction mix for RT-PCR • contains reaction buffer, dNTP mix (with dUTP instead of dTTP), and 15 mM MgCl <sub>2</sub>
3	blue cap	MgCl <sub>2</sub> stock solution, 25 mM • 1 ml • to adjust MgCl <sub>2</sub> concentration
4	colorless cap	H <sub>2</sub> O, sterile-filtered, PCR grade • 2x 1 ml • to adjust the final reaction volume

## Storage and Stability

The complete kit is stable through the expiration date printed on the label if stored properly at -15 to -25°C.

- The kit is shipped on dry ice.
- Once the kit is opened, store the kit components as described in the following table:

Vial	Label	Storage
1	red cap	LightCycler RT-PCR Enzyme Mix • Store at -15 to -25°C.
2	red cap	LightCycler RT-PCR Reaction Mix Hyb-Probe, 5x conc. • <b>Avoid repeated freezing and thawing!</b>
3	blue cap	MgCl <sub>2</sub> stock solution, 25 mM
4	colorless cap	H <sub>2</sub> O, sterile, PCR-grade • Store at -15 to -25°C.



**onal  
ment and  
nts  
ed**

Refer to the list below for additional reagents and equipment required to perform RT-PCR reactions with the LightCycler RNA Amplification Kit HybProbe using the LightCycler System:

- LightCycler System\* (LightCycler 2.0 Instrument\*, LightCycler 1.5 Instrument\*, or an instrument version below)
- LightCycler Capillaries\*
- Standard benchtop microcentrifuge containing a rotor for 2.0 ml reaction tubes

⑨ The LightCycler System provides adapters that allow LightCycler Capillaries to be centrifuged in a standard microcentrifuge rotor.

or

- LightCycler Carousel Centrifuge 20\* for use with the LightCycler 2.0 Carousel (optional)

⚠ If you use a LightCycler Instrument version below 2.0, you need in addition the LightCycler Carousel Centrifuge 2.0 Bucket 2.1\*. To adapt the LightCycler 2.0 Carousel to the former LightCycler Carousel Centrifuge, you need the LightCycler Carousel Centrifuge 2.0 Rotor Set\*.

- LightCycler Color Compensation Set\*\* (optional)
- Uracil-DNA N-Glycosylase, heat-labile\*\* (optional)
- Nuclease-free, aerosol-resistant pipette tips
- Pipettes with disposable, positive-displacement tips
- Sterile reaction (Eppendorf) tubes for preparing master mixes and dilutions

⑩ \* If you want to perform color compensation when using LightCycler Red 640 and 705-labeled HybProbe pairs in dual color experiments in the same capillary. See section Related Procedures for details.

⑪ † for prevention of carry-over contamination; see section Related Procedures for details.

⑫ \* available from Roche Applied Science; see Ordering Information for details.

1. What this Product Does, continued

**Application**

The LightCycler RNA Amplification Kit HybProbe is designed for use in research studies. The kit provides reagents, including RT-PCR enzyme mix, reaction mix, MgCl<sub>2</sub>, and PCR grade water, for very sensitive detection and quantification of defined RNA sequences using the LightCycler System (if suitable primers and HybProbe probes are supplied).

It can also be used to genotype single nucleotide polymorphisms (SNPs) and analyze mutations. Further, it can be used with heat-labile Uracil-DNA N-Glycosylase (UNG) to prevent carry-over contamination during PCR.

In principle, the LightCycler RNA Amplification Kit HybProbe can be used for the amplification and detection of every RNA target. However, you would need to adapt each amplification protocol to the reaction conditions of the LightCycler System and design specific PCR primers and HybProbe probes for each target. See the LightCycler Operator's Manual for general recommendations.

⚠ The amplicon size should not exceed 1 kb in length. For optimum results, select a product length of 700 bp or less.

⚠ The performance of the kit described in this Instruction Manual is guaranteed only when it is used with the LightCycler System.

## 2. How to Use this Product

### 2.1 Before You Begin

#### Sample Material

Use any template RNA (e.g., total RNA or mRNA) suitable for RT-PCR in terms of purity, concentration, and absence of inhibitors.

▲ Use up to 500 ng total RNA or 100 ng mRNA. Higher concentrations might result in inhibition of the reaction.

③ If the concentration of template RNA is lower than 10 µg/ml, the addition of unspecific carrier RNA (e.g., MS2 RNA\*) is recommended. To avoid loss of template RNA due to adsorption effects, the total RNA concentration of solutions (template plus carrier RNA) should not be lower than 10 µg/ml.

For reproducible isolation of nucleic acids use:

- either the MagNA Pure LC Instrument together with a dedicated MagNA Pure LC reagent kit (for automated isolation)
- or a High Pure nucleic acid isolation kit (for manual isolation).

See Ordering Information for selected products recommended for isolation of template RNA. For further information consult the Roche Applied Science Biochemicals catalog or the website: [www.roche-applied-science.com](http://www.roche-applied-science.com).

#### Primers

Use PCR primers at a final concentration of 0.3–1 µM. The recommended starting concentration is 0.5 µM each.

▲ If amplification curves show the "hook effect" (i.e., after an exponential rise, the fluorescence signal reaches a maximum, then significantly drops in the later cycles), try using asymmetric PCR. To perform asymmetric PCR, use a higher concentration (0.5 to 1 µM) of the forward primer (i.e., the one priming the strand that binds the probes) and a lower concentration of the reverse primer (titrate down from 0.5 to 0.2 µM). This favors synthesis of the strand that binds the HybProbe probes and will improve the subsequent melting curve analysis.

#### HybProbe Probes

Use HybProbe probes at a final concentration of 0.2 µM each. In some cases it might be advantageous to double the concentration of the LightCycler Red-labeled probe to 0.4 µM.

③ See the LightCycler Operator's Manual and the LightCycler Online Resource Site ([www.lightcycler-online.com](http://www.lightcycler-online.com)) for detailed information on designing HybProbe probes and labeling HybProbe probes with various dyes. In addition, LightCycler Probe Design Software\* can help you design HybProbe pairs.

### 2.1. Before You Begin, continued

#### MgCl<sub>2</sub>

To ensure specific and efficient amplification with the LightCycler System, must optimize the MgCl<sub>2</sub> concentration for each target. The LightCycler PCR Reaction Mix HybProbe contains a MgCl<sub>2</sub> concentration of 3 mM (final concentration). The optimum concentration for RT-PCR with the LightCycler System may vary from 3 to 7 mM.

The table below shows the volume of the MgCl<sub>2</sub> stock solution (vial 3, 1 cap) that you must add to a 20 µl reaction (final PCR volume) to increase MgCl<sub>2</sub> concentration.

To reach a final Mg <sup>2+</sup> concentration (mM) of:	3	4	5	6	7
Add this amount of 25 mM MgCl <sub>2</sub> stock solution (µl):	0	0.8	1.6	2.4	3.

#### Negative Control

Always run a negative control with the samples. To prepare a negative control replace the template RNA with PCR-grade water (vial 4, colorless cap).

#### DNA Contamination Control

To test the template RNA for contamination with residual genomic DNA, form PCR in combination with LightCycler DNA Master HybProbe, LightCycler FastStart DNA Master HybProbe, or LightCycler FastStart DNA Master HybProbe. Because in this experimental setup the reverse transcription step is omitted, any PCR product generated is a signal for DNA contamination or RNA template preparation.

The following procedure is optimized for use with the LightCycler System.

▲ Program the LightCycler Instrument before preparing the reaction mixes. A LightCycler protocol that uses the LightCycler RNA Amplification Kit Hyb-Probe contains the following programs:

- **Reverse Transcription** of template RNA
- **Denaturation** of cDNA/RNA hybrid
- **Amplification** of the cDNA
- **Melting Curve** for amplicon analysis (optional: only needed for SNP or mutation detection)
- **Cooling** the rotor and thermal chamber

For details on how to program the experimental protocol, see the LightCycler Operator's Manual.

- ▲ <sup>1)</sup> Temperature Transition Rate/Slope is 20°C/sec, except where indicated.
- ▲ Set all other protocol parameters not listed in the table below to '0'.

2.2 Procedure, continued

The following table shows the PCR parameters that must be programmed for a LightCycler RT-PCR run with the LightCycler RNA Amplification Kit HybProbe.

Analysis Mode	Cycles	Segment	Target Temperature <sup>1)</sup>	Hold Time	Acquisition Mode
<b>Reverse Transcription</b>					
None	1		55°C	10 min <sup>2)</sup>	none
<b>Denaturation</b>					
None	1		95°C	30 s	none
<b>Amplification</b>					
Quantification	45		Denaturation 95°C	0 s <sup>3)</sup>	none
			Annealing primer dependent <sup>2)</sup>	15 s	single
			Extension 72°C <sup>3)</sup>	product [bp] / 25 s <sup>3)</sup>	none
<b>Melting Curve (optional)</b>					
Melting Curves	1		Denaturation 95°C	0 s	none
			Annealing HybProbe $T_m$ - 5°C	30-60 s	none
			Melting 95°C	0 s	continuous
			slope = 0.1°C/sec <sup>1)</sup>		
<b>Cooling</b>					
None	1		40°C	30 s	none

- <sup>2)</sup> For initial experiments, set the target temperature (*i.e.*, the primer annealing temperature) 5°C below the calculated primer  $T_m$ .
- <sup>3)</sup> If the primer annealing temperature is low (<55°C), reduce the temperature transition rate/slope to 2-5°C/s.
- <sup>4)</sup> When amplifying GC-rich templates or templates with a high degree of secondary structures, it is recommended to extend the incubation time to 30 min.
- <sup>5)</sup> When amplifying GC-rich templates or templates with a high degree of secondary structures, it is recommended to extend the incubation time to 5 s.
- <sup>6)</sup> For greater precision in target quantification experiments, it can be advantageous (in some cases) to choose longer annealing and extension times for the amplification cycles.

**Fluorescence and Setup Parameters**

Parameter	Setting
<b>All LightCycler Software Versions</b>	
Seek Temperature	55°C
<b>LightCycler Software prior to Version 3.5</b>	
Display Mode	fluorescence channel F2 (for LightCycler Red 640) or F3 (for LightCycler Red 705)
<b>Fluorimeter Gain Value</b>	
Channel 1 (F1)	1
Channel 2 (F2)	15
Channel 3 (F3)	30
<b>LightCycler Software Version 3.5</b>	
Display Mode	<ul style="list-style-type: none"> <li>during run</li> <li>for analysis</li> </ul>

- fluorescence channel F2 (for LightCycler Red 640) or F3 (for LightCycler Red 705)
- For quantification analysis: divide by Channel F1 for single color experiments; divide by 'Back-F1' for dual color experiments (e.g., F2/Back-F1). For melting curve analysis do not divide by Channel F1 or Back-F1.

Fluorescence Gains not required

Ⓢ In data created with LightCycler Software Version 3.5, all fluorescence values are normalized to a fluorescence gain of "1". This produces a different scale on the Y-axis than that obtained with previous LightCycler software versions. This difference does not affect the crossing points nor any calculated concentrations obtained.

*continued on next page*

Parameter	Setting
<b>LightCycler Software Version 4.0</b>	
Default Channel	<ul style="list-style-type: none"> <li>during run</li> <li>for analysis</li> </ul>

- Depending on the LightCycler Red dye used for labeling the HybProbe probe, choose Channel 610, 640, 670, or 705.
- Depending on the LightCycler Red dye used for labeling the HybProbe probe, choose Channel 610, 640, 670, or 705. For quantification analysis: divide by channel 530 for single color experiments; divide by 'Back 530' for dual color experiments (e.g., 640/Back 530). For automated  $T_m$  Calling analysis do not divide by channel 530 or "Back 530".
- Ⓢ Channel 610 and 670 are available on a LightCycler 2.0 Instrument only.

Fluorescence Gains	not required
"Max. Seek Pos"	Enter the number of sample positions the instrument should look for.
"Instrument Type"	"6 Ch.": for LightCycler 2.0 Instrument (selected by default) "3 Ch.": for LightCycler 1.5 Instrument and instrument versions below
"Capillary Size"	Select "20 $\mu$ " as the capillary size for the experiment. ⚠ For the "6 Ch." instrument type only.

**Preparation of the PCR Mix**

Proceed as described below for a 20  $\mu$ l standard reaction.  
⚠ Do not touch the surface of the capillaries. Always wear gloves when handling the capillaries.

- Depending on the total number of reactions, place the required number of LightCycler Capillaries in precooled centrifuge adapters or in a LightCycler Sample Carousel in a precooled LightCycler Centrifuge Bucket.
  - Thaw the solutions and, for maximal recovery of contents, briefly spin vials in a microcentrifuge before opening.
  - Mix carefully by pipetting up and down and store on ice.
  - ⚠ A reversible precipitate may form in the LightCycler RT-PCR Reaction Mix HybProbe (Vial 2, red cap) during storage. If a precipitate is visible, place the RT-PCR Reaction Mix at room temperature and mix gently from time to time until the precipitate is completely dissolved. This does not influence the performance in RT-PCR.
- Prepare a 10x conc. solution of PCR primers and a 10x conc. solution of HybProbe probes.

- 4 In a 1.5 ml reaction tube on ice, prepare the PCR Mix for one 20  $\mu$ l reaction by adding the following components in the order mentioned below:

Component	Volume	Final conc.
H <sub>2</sub> O, PCR-grade	x $\mu$ l	—
(vial 4, colorless cap)		
MgCl <sub>2</sub> stock solution	y $\mu$ l	Use concentration that is optimal for the target.
(vial 3, blue cap)		
LightCycler RT-PCR Reaction Mix	4.0 $\mu$ l	1x
HybProbe, 5x conc.		
(vial 2, red cap)		
Primer mix, 10x conc. <sup>1)</sup>	2.0 $\mu$ l	0.3 to 1.0 $\mu$ M each (recommended conc. is 0.5 $\mu$ M)
HybProbe mix, 10x conc. <sup>2)</sup>	2.0 $\mu$ l	0.2 to 0.4 $\mu$ M each
LightCycler RT-PCR Enzyme	0.4 $\mu$ l	1x
Mix (vial 1, green cap)		
<b>Total volume</b>	<b>19 <math>\mu</math>l</b>	

- 5 To prepare the PCR Mix for more than one reaction, multiply the amount in the "Volume" column above by z, where z = the number of reactions to be run + one additional reaction.
- 6 Mix gently by pipetting up and down. Do not vortex.
- Pipet 19  $\mu$ l PCR mix into each LightCycler Capillary.
  - Add 1  $\mu$ l RNA template.
  - Seal each capillary with a stopper.
- 7 Place the adapters (containing the capillaries) into a standard benchtop microcentrifuge.
- 8 Place the centrifuge adapters in a balanced arrangement within the centrifuge.
- Centrifuge at 700x g for 5 s (3000 rpm in a standard benchtop microcentrifuge).
  - Alternatively, use the LightCycler Carousel Centrifuge for spinning the capillaries.
- 9 Transfer the capillaries into the sample carousel of the LightCycler Instrument.
- 10 Cycle the samples as described in section "LightCycler Protocol".
- 11 Due to possible primer/primer interactions generated during storage it might be necessary to preheat the PCR primer mix for 1 min at 95°C before starting the reaction to achieve optimum sensitivity.
- 12 If you want to perform dual color detection using LightCycler Red 640- and Red 705-labeled HybProbe pairs simultaneously in one capillary, either use two separated HybProbe mixes (then you will have to add 2  $\mu$ l each from both of the two mixes) or combine both HybProbe pair preparations in one mix. (You will then have to add 2  $\mu$ l only from this combined HybProbe mix.)

### 2.3 Related Procedures

#### Color Compensation

If using acceptor HybProbe probes that contain different LightCycler Red labels in the same capillary, you must compensate for the crosstalk between individual channels by using a (previously generated) color compensation file. You can activate a previously stored color compensation file during the LightCycler Instrument run or use it for data analysis after the run.

- 1 Although the optical filters of each detection channel of the LightCycler Instrument are optimized for the different emission maxima of the fluorescent dyes, some residual crosstalk between the channels will occur unless you correct for it with a color compensation file.

2 Color Compensation is instrument-specific. Therefore, a color compensation file must be generated for each LightCycler Instrument.

- 3 No universal color compensation set is available for 6-channel applications on a LightCycler 2.0 Instrument. All multicolor assays must use a specific color compensation protocol. You must prepare a new color compensation object for each set of parameters.

- 4 For more information on the generation and use of a color compensation file, see the LightCycler Operator's Manual, the LightCycler Online Resource Site ([www.lightcycler-online.com](http://www.lightcycler-online.com)), or the pack inserts of the LightCycler Color Compensation Set and LightCycler Multiplex DNA/Master HybProbe.

#### Prevention of Carry-Over Contamination

Heat-labile Uracil-DNA N-Glycosylase (UNG) is suitable for preventing carry-over contamination in PCR. This carry-over prevention technique involves incorporating deoxyuridine triphosphate (dUTP, a component of the reaction mixes of all LightCycler reagent kits) into amplification products, then pretreating later PCR mixtures with UNG. If a dUTP-containing contaminant is present in the later PCRs, it will be cleaved by a combination of the UNG and the high temperatures of the initial denaturation step; it will not serve as a PCR template.

Proceed as described in the table below to prevent carry-over contamination using heat-labile UNG:

- 1 Add 1  $\mu$ l heat-labile UNG to the master mix per 20  $\mu$ l final reaction volume.
- 2 Add template RNA and incubate the completed reaction mixture for 5 min at room temperature.
- 3 Destroy any contaminating template and inactivate the UNG enzyme by performing the reverse transcription step at 55°C.
  - 4 Do not perform an additional inactivation step at higher temperatures (55°C) since the reverse transcriptase would be inactivated.
- 4 When performing an additional melting curve analysis, the use of UNG lowers the respective melting temperature ( $T_m$ ) by approx. 1°C.

## 4. Troubleshooting

Possible Cause	Recommended Action
Precipitate in RT-PCR reaction buffer.	Place the RT-PCR reaction mix at room temperature. Mix gently from time to time until the precipitate is completely dissolved and place on ice.
Amplification reaches plateau phase before the program is finalized.	The program can be finished by clicking on the End Program button. The next cycle program will start automatically.
Log-linear phase of amplification just starts when the program finishes.	Reduce the number of cycles in the cycle program. <ul style="list-style-type: none"> <li>Increase number of cycles by 10 in the corresponding cycle program.</li> <li>Improve PCR conditions (e.g., MgCl<sub>2</sub> concentration, primer and probe design).</li> <li>Use higher amount of starting material.</li> <li>Repeat the run.</li> </ul>
No amplification occurs.	Check the channel chosen in the programming screen and change. (The data obtained up to this point will be saved.) <ul style="list-style-type: none"> <li>Check for missing reagents.</li> <li>Titrate MgCl<sub>2</sub> concentration.</li> <li>Check for missing or defective dye.</li> </ul>
Pipetting errors or omitted reagents.	Check the cycle program. For HybProbe detection format, choose "single" as acquisition mode at the end of the annealing phase.
Measurements do not occur	Do not use amplicons > 1 kb. Amplification efficiency is reduced with amplicons of this size. Optimal results are obtained for amplicons up to 700 bp.
Amplicon length is > 1 kb.	Inhibitory effects of the sample material due to insufficient purification. <ul style="list-style-type: none"> <li>Do not use more than 8-10 µl of RNA per 20 µl RT-PCR reaction mixture.</li> <li>Purify the nucleic acids to ensure removal of inhibitory agents.</li> </ul>
Unsuitable HybProbe probes.	Check sequence and location of the HybProbe probes. <ul style="list-style-type: none"> <li>Check RNA quality on a gel.</li> <li>Check RNA with an established primer pair if available.</li> </ul>
RNA degradation due to improper storage or isolation.	Gain settings cannot be changed during or after a run. Before repeating the run, use the Real Time Fluorimeter option to find suitable gain settings. The background fluorescence at measuring temperature should not exceed 20 for HybProbe probes. <b>⚠</b> Avoid bleaching of dyes by using an extra sample for this procedure.
Unsuitable gain settings.	<ul style="list-style-type: none"> <li>Store the dye containing reagents at -20°C, protected from light.</li> <li>Avoid repeated freezing and thawing.</li> <li>Low HybProbe signals can be improved by using a two times higher concentration of the LC Red-labeled probe than of the fluorescein-labeled probe.</li> </ul>
Fluorescence intensity is too high and reaches overflow.	Optimize gain setting using the Real Time Fluorimeter function. Change the gain settings in the cycle programs appropriately and repeat the run.
Fluorescence intensity is too low.	Low concentration or deterioration of dyes in the reaction mixtures due to unsuitable storage conditions.  Chosen gain are too low.

The following amplification curves were obtained using the LightCycler RNA Amplification Kit HybProbe in combination with the LightCycler Control Kit RNA targeting *in vitro* transcribed cytokine RNA template. The single color detection protocol was performed using LightCycler Red 640 as acceptor fluorophore. Displayed are the results in channel F2 and F3, with and without color compensation. Equivalent results will be obtained using single color detection with LightCycler Red 705 as acceptor fluorophore or dual color detection with LC Red 640- and LC Red 705-labeled HybProbe pairs simultaneously.

The fluorescence values versus cycle number are displayed. 100 copies of the cytokine RNA can be reproducibly detected by amplification in the LightCycler Instrument using the HybProbe detection format.

Fig. 1: Serially diluted samples containing 10<sup>2</sup> to 10<sup>8</sup> copies of cytokine RNA template from the LightCycler Control Kit RNA were amplified using the LightCycler RNA Amplification Kit HybProbe in a LightCycler instrument. As a negative control, template RNA was replaced by PCR-grade water. LightCycler Red 640 was used as acceptor fluorophore. Fig. 1a and 1b display results in detection channel F2 without and with color compensation. Quantification analysis was done using LightCycler Software 3.5 applying arithmetic background subtraction.

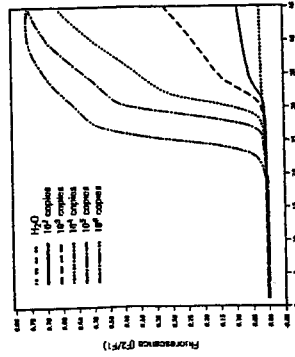

Fig. 1a: Channel F2 (F2/F1) without color compensation

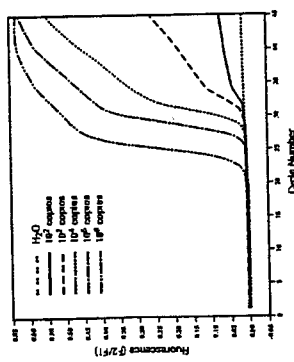

Fig. 1b: Channel F2 (F2/F1) with color compensation

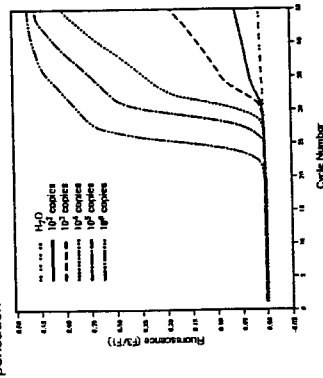

Fig. 1c: Channel F3 (F2/F1) without color compensation

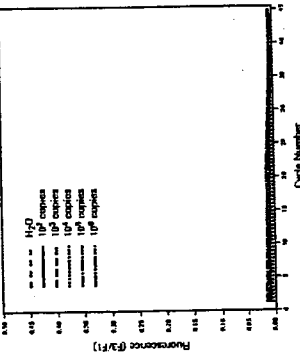

Fig. 1d: Channel F3 (F2/F1) with color compensation

**Possible causes**

Poor PCR efficiency due to non-optimized reaction conditions.

**Recommendation**

- Titrate MgCl<sub>2</sub> concentration
- Primer concentration should be in the range of 0.2 to 1.0 μM, probe concentration should be in the range of 0.2 to 0.4 μM.
- Check annealing temperature of primers and probes.
- Check experimental protocol.
- Always run a positive control along with your samples.
- Increase amount of RNA template up to 500 ng total RNA or 100 ng mRNA.

Poor PCR efficiency due to high GC content or high degree of secondary structures of the RNA.

Extend the incubation time for Reverse Transcription to 30 min, and for denaturation during cycling to 5 s.

**Pipetting errors**

When using HybProbe probes and single color detection, pipetting errors can be diminished by interpreting the results in the F2/F1 or F3/F1 (840/530 or 705/530) mode.

Repeat centrifugation step.

Prepared PCR mix is still in the upper vessel of the capillary.  
Air bubble is trapped in the capillary tip.

Always wear gloves when handling the capillaries.

Skin oils on the surface of the capillary tip

Contamination

- Exchange all critical solutions.
- Pipet reagents on a clean bench.
- Close lid of the negative control reaction tube immediately after pipetting.
- Use heat-labile UNG for decontamination of carry-over cross contamination.

Reverse transcription  
negative control  
primers are positive.

## 5. Additional Information on this Product

### How this Product Works

The LightCycler RNA Amplification Kit HybProbe is designed specifically for the HybProbe detection format using the LightCycler System. It is used to perform one-step RT-PCR in 20 μl glass capillaries. Amplification and on-line monitoring of the template RNA is achieved by a combined procedure on the LightCycler Instruments. The results are interpreted directly after completing the PCR. The amplicon is detected by fluorescence using target-specific HybProbe probes (not provided by the kit).

The LightCycler RNA Amplification Kit HybProbe provides convenience, high performance, reproducibility, and minimizes contamination risk. Only template RNA, PCR primers, HybProbe probes, and additional MgCl<sub>2</sub> (if necessary), have to be added.

### Background Information

HybProbe probes are two different short oligonucleotides that bind to an internal sequence of the amplified fragment during the annealing phase of the amplification cycle. One probe is labeled at the 5'-end with a LightCycler Red fluorophore (LightCycler Red 610\*, 640, 670\* or 705); it is also 3'-phosphorylated, so it cannot be extended. The other probe is labeled at the 3'-end with fluorescein. When hybridized to the template DNA, the two probes are close enough to allow fluorescence resonance energy transfer (FRET) between the two fluorophores.

During FRET, fluorescein (the donor fluorophore) is excited by the light source of the LightCycler Instrument. Fluorescein transfers part of this excitation energy to the LightCycler Red dye (the acceptor fluorophore). Then, the LightCycler Red dye emits fluorescence, which is measured by the LightCycler Instrument. HybProbe probes that contain different LightCycler Red labels can be used separately (for single color detection experiments) or combined (for dual color detection experiments). Color compensation is not necessary for single color detection experiments. However, if you are using HybProbe probes to perform dual color experiments in a single capillary, you must also use a color compensation file. Color compensation may be applied either during or after a run on the LightCycler Instrument.

\* LightCycler Red 610 and LightCycler Red 670 can be used on a LightCycler 2.0 Instrument only.

## 6. Supplementary Information

### 6.1 Conventions

#### Text Conventions

To make information consistent and memorable, the following text conventions are used in this Instruction Manual:

Text Conventions	Usage
Numbered stages labeled ①, ②, etc.	Stages in a process that usually occur in the order listed.
Numbered instructions labeled ①, ②, etc.	Steps in a procedure that must be performed in the order listed.
Asterisk *	Denotes a product available from Roche Applied Science.

### Symbols

In this Instruction Manual, the following symbols are used to highlight important information:

Symbol	Description
	Information Note: Additional information about the current topic or procedure.
	Important Note: Information critical to the success of the procedure or use of the product.

### 6.2 Changes to Previous Version

- Concentration of RT-PCR Reaction Mix: Correct concentration is "5x conc.", which was stated wrongly as "10x conc." in previous versions.
- Information for usage of LightCycler Software 4.0 added.
- Standard protocol replaces protocol specific for the LightCycler Control Kit RNA.
- References describing product application added.

### 6.3 Ordering Information

Roche Applied Science offers a large selection of reagents and systems for life science research. For a complete overview of related products and manuals, please visit and bookmark our home page [www.roche-applied-science.com](http://www.roche-applied-science.com), and our Special Interest Sites including:

- The LightCycler System family for real-time, online PCR: <http://www.lightcycler-online.com>

Product	Pack Size	Cat. No.
LightCycler 2.0 Instrument	1 instrument plus accessories	03 351 414 001
LightCycler 1.5 Instrument	1 instrument plus accessories	04 484 495 001
LightCycler Capillaries (20 µl)	1 pack (8 boxes, each with 96 capillaries and stoppers)	11 909 339 001
LC Carousel Centrifuge 2.0 Rotor Set	1 rotor + 2 buckets	03 724 687 001
LC Carousel Centrifuge 2.0 Bucket 2.1	1 bucket	03 724 688 001
LightCycler Carousel Centrifuge 2.0	1 centrifuge plus rotor and bucket	03 709 507 001 (115 V) 03 709 562 001 (230 V)
MagNA Pure LC Instrument	1 instrument plus accessories	12 236 931 001
LightCycler Software 4.0	1 software package	03 640 012 001
LightCycler Probe Design Software 2.0	1 software package	04 342 054 001

### Instruments and Accessories

## Additional Information on this Product, continued

- Buck MB *et al.* Antiestrogens Induce Growth Inhibition by Sequential Activation of p38 Mitogen-Activated Protein Kinase and Transforming Growth Factor-(beta) Pathways in Human Breast Cancer Cells. *Mol Endocrinol* (2004); **18**:1643-57.
- Schalk JAC *et al.* Estimation of the number of infectious measles viruses in live virus vaccines using quantitative real-time PCR. *Journal of Virological Methods* (2004); **117**:179-87.
- Straub B *et al.* Real-time quantitative reverse transcriptase-polymerase chain reaction for luteinizing hormone-releasing hormone receptor gene mRNA expression in human prostate cancer. *Urology* (2003); **62**:172-6.
- Busch M *et al.* Functional Analysis of the Early Steps of Carotenoid Biosynthesis in Tobacco. *Plant Physiol.* (2002); **128**:439-53.
- Nellemann C *et al.* Quantification of antiandrogen effect determined by LightCycler technology. *Toxicology* (2001); **163**:29-38.

The LightCycler RNA Amplification Kit HybProbe is function tested using the LightCycler Control Kit RNA.

## Quality Control



Product	Pack Size	Cat. No.
4A Isolation Kits		
Magna Pure LC RNA Isolation Kit - High Performance	1 Kit (192 isolations)	03 542 394 001
Magna Pure LC RNA Isolation Kit III (Tissue)	1 Kit (192 isolations)	03 330 591 001
Magna Pure LC mRNA Isolation Kit I (Blood, Blood Cells)	1 Kit (192 isolations)	03 004 015 001
Magna Pure LC mRNA Isolation Kit II (Tissue)	1 Kit (192 isolations)	03 172 827 001
High Pure RNA Isolation Kit	1 Kit (50 isolations)	11 828 865 001
High Pure RNA Tissue Kit	1 Kit (50 isolations)	12 033 874 001
High Pure Viral RNA Kit	1 Kit (100 isolations)	11 858 882 001
LightCycler RNA Amplification Kit SYBR Green I	1 Kit (98 reactions)	12 015 137 001
LightCycler RNA Amplification Kit HybProbe	1 Kit (98 reactions)	12 015 145 001
LightCycler RNA Master SYBR Green I	1 Kit (98 reactions)	03 084 780 001
LightCycler RNA Master HybProbe	1 Kit (98 reactions)	03 018 954 001
Transcriptor Reverse Transcriptase	250 U 500 U 2000 U	03 531 317 001 03 531 295 001 03 531 287 001
Transcriptor First Strand cDNA Synthesis Kit	1 Kit	04 379 012 001
First Strand cDNA Synthesis Kit for RT-PCR (AMV)	1 Kit	11 483 188 001
LightCycler DNA Master HybProbe	1 Kit (98 reactions)	12 015 102 001
LightCycler FastStart DNA Master HybProbe	1 Kit (480 reactions)	12 158 825 001
LightCycler FastStart DNA Master HybProbe	1 Kit (98 reactions) 1 Kit (480 reactions)	03 003 248 001 12 239 272 001
LightCycler FastStart DNA Master <sup>Plus</sup> HybProbe	1 Kit (98 reactions) 1 Kit (480 reactions)	03 515 575 001 03 515 567 001
LightCycler DNA Master SYBR Green I	1 Kit (98 reactions) 1 Kit (480 reactions)	12 015 089 001 12 158 817 001
LightCycler FastStart DNA Master SYBR Green I	1 Kit (98 reactions) 1 Kit (480 reactions)	03 003 230 001 12 239 284 001
LightCycler FastStart DNA Master <sup>Plus</sup> SYBR Green I	1 Kit (98 reactions) 1 Kit (480 reactions)	03 515 888 001 03 515 885 001
LightCycler Color Compensation Set	1 set (5 reactions)	12 158 850 001
LightCycler Multicolor Demo Set	20 reactions & 5 color compensation runs	03 624 854 001
LightCycler Control Kit RNA	1 Kit (50 control reactions)	12 158 841 001
Uracil-DNA N-Glycosylase, heat-labile RNA MS2	100 U 10 $\mu$ g U (500 $\mu$ l)	11 775 387 001 10 185 948 001

Roche Applied Science 20

LIMITED LICENSE: A license under U.S. Patents 4,683,202, 4,683,195, and 4,965,188 and their foreign counterparts, owned by Roche Molecular Systems, Inc. and F. Hoffmann-La Roche Ltd ("Roche"), has an up-front fee component and a running-royalty component. The purchase price of this product includes limited, nontransferable rights under the running-royalty component to use only this amount of the product to practice the Polymerase Chain Reaction ("PCR") and related processes described in said patent solely for the research and development activities of the purchaser when this product is used in conjunction with a thermal cycler whose use is covered by the up-front fee component. Rights to the up-front fee component must be obtained by the end user in order to have a complete license to use this product in the PCR process. These rights under the up-front fee component may be purchased from Applied Biosystems or obtained by purchasing an Authorized Thermal Cycler. No right to perform or offer commercial services of any kind using PCR, including without limitation reporting the results of purchaser's activities for a fee or other commercial consideration, is hereby granted by implication or estoppel. Further information on purchasing licenses to practice the PCR process may be obtained by contacting the Director of Licensing, Applied Biosystems, 850 Lincoln Centre Drive, Foster City, California 94404 or the Licensing Department, Roche Molecular Systems, Inc., 1145 Atlantic Avenue, Alameda, California 94501.

DISCLAIMER OF LICENSE: No rights for any other application, including any in vitro diagnostic application, are conveyed expressly, by implication or by estoppel under any patent or patent applications owned by Roche Molecular Systems, Inc. and F. Hoffmann-La Roche Ltd claiming homogeneous or real-time detection methods.

Purchase of this product includes a limited non-transferable end-user license to the purchaser under the Hybridization Probe Technology owned by Idaho Technology under U.S. Patents 6,174,670 and foreign counterparts to use this product for any purpose.

The technology used for the LightCycler System is licensed from Idaho Technology Inc. Salt Lake City, UT, USA.

6.5 Trademarks

LightCycler, Magna Pure, High Pure, FastStart and HybProbe are Trademarks of Member of the Roche Group. SYBR is a trademark of Molecular Probes, Inc.

Roche Applied Science 21

# **QIAamp® Viral RNA Mini Kit Handbook**

For purification of viral RNA from

Plasma

Serum

Cell-free body fluids

Cell-culture supernatants

**January 1999**



## Trademarks

Genentech is a registered trademark of Millipore Corporation. Corex is a registered trademark of Corning, Inc.  
UltraFree is a registered trademark of Millipore Corporation.

Registered names, trademarks, etc. used in this document, even when not specifically marked as such, are not to be considered unprotected by law.

The PCR process is covered by US Patents 4,683,195 and 4,683,202 and foreign equivalents issued to Hoffmann-La Roche AG.

© 2000 QIAGEN, all rights reserved.

## QIAGEN Worldwide

### QIAGEN Companies

Australia	QIAGEN Pty Ltd ABN 75 072 382 944	PO Box 25 • Clifton Hill • Victoria 3068 Orders 03-9489-3666 • Fax 03-9489-3888 • Technical 1-800-243-0666
Canada	QIAGEN Inc.	2800 Argente Road • Unit 7 • Mississauga • Ontario • L5N 8L2 Orders 800-572-9613 • Fax 800-713-5951 • Technical 800-DNA-PREP (800-362-7737)
France	QIAGEN S.A.	3 avenue du Canada • IP 809 • 91974 COURTABOEUF CEDEX Orders 01-60-920-920 • Fax 01-60-920-925 • Technical 01-60-920-930
Germany	QIAGEN GmbH	QIAGEN Strasse 1 • 40724 Hilden Orders 02103-29-12000 • Fax 02103-29-22000 • Technical 02103-29-12400
Italy	QIAGEN S.p.A.	Via Grosio, 10/10 • 20151 Milano Orders 02-33430411 • Fax 02-33430426 • Technical 02-33430414
Japan	QIAGEN K.K.	Forefront Tower II • 13-1, Kachidoki 3 Chome • Chuo-ku, Tokyo 104-0054 Telephone 03-5547-0811 • Fax 03-5547-0818 • Technical 03-5547-0811
Switzerland	QIAGEN AG	Auf dem Wolf 39 • 4052 Basel Orders 061-319-3030 • Fax 061-319-3033 • Technical 061-319-3031
UK and Ireland	QIAGEN Ltd.	Boundary Court • Galwick Road • Crawley • West Sussex, RH10 9AX Orders 01293-422-911 • Fax 01293-422-922 • Technical 01293-422-999
USA	QIAGEN Inc.	28159 Avenue Stanford • Valencia • CA 91355 Orders 800-426-8157 • Fax 800-718-2056 • Technical 800-DNA-PREP (800-362-7737)

www.qiagen.com

### QIAGEN Distributors

Please see the last page for contact information for your local QIAGEN distributor.

## Contents

### Kit Contents

### Storage Conditions

### Reagents and Equipment to be Supplied by User

### Product Use Limitations

### Product Warranty and Satisfaction Guarantee

### Technical Assistance

### The QIAamp Principle and Procedure

#### Cellular DNA contamination

#### Warnings and precautions

#### Sample volumes

#### Lysis

#### QIAamp spin-column procedure

#### Adsorption to the QIAamp membrane

#### Removal of residual contaminants

#### Elution with Buffer AVE

#### Determination of yield

#### Determination of viral RNA length

### QIAvac 6S Vacuum Manifold

#### QIAvac 6S handling guidelines

### Important Notes Before Starting

#### Preparation of reagents

#### Handling of QIAamp spin columns

#### Centrifugation

### QIAamp Viral RNA Mini Spin Protocol

### QIAamp Viral RNA Mini Vacuum Protocol

### Protocol for Large Sample Volumes

### Protocol for Sample Concentration

### Protocol for Isolation of Cellular, Bacterial or Viral DNA from Urine

### Troubleshooting Guide

### Appendix

### Ordering Information

### QIAGEN International Sales and Distributors

4

4

5

5

5

6

7

7

8

8

8

10

10

10

10

11

11

12

13

14

14

16

17

18

20

23

24

25

26

29

31

35

## Kit Contents

QIAamp Viral RNA Mini Kits			
Cat. No.	52904	52906	52908
Preparations per kit	50	250	1000
QIAamp Spin Columns	50	250	1000
Collection Tubes (2-ml)	200	1000	4000
Buffer AVL*	31 ml	5 x 31 ml	3 x 190 ml
Buffer AW1* (concentrate)	19 ml	95 ml	2 x 175 ml
Buffer AW2† (concentrate)	13 ml	66 ml	2 x 127 ml
Buffer AVE†	3 x 2 ml	8 x 2 ml	32 x 2 ml
Carrier RNA (poly A)	310 µg	5 x 310 µg	3 x 1900 µg
Handbook	1	1	1

\* Contains chaotropic salt which is an irritant. Take appropriate laboratory safety measures, and wear gloves when handling. Not compatible with disinfecting reagents which contain bleach.

† Contains sodium azide as a preservative. Sodium azide is highly toxic and may react explosively with lead and copper drain pipes. Take appropriate safety measures, and wear gloves when handling. Dispose of azide containing solutions according to your institutions waste-disposal guidelines.

## Storage Conditions

QIAamp® spin columns should be stored dry at room temperature (15–25°C); storage at higher temperatures should be avoided. All solutions should be stored at room temperature unless otherwise stated. QIAamp spin columns, all buffers and reagents can be stored for up to 1 year under the above conditions without showing any reduction in performance. Lyophilized Carrier RNA is stable for up to 1 year when stored at room temperature. Carrier RNA dissolved in Buffer AVL however must be stored at 2–8°C and is then stable for up to 6 months. If Buffer AVL/Carrier RNA solution is stored at room temperature, it will be stable for no more than 2 weeks. Buffer AVL/Carrier RNA solution develops a precipitate when stored at 2–8°C that must be redissolved by warming at 80°C before use.

**DO NOT warm Buffer AVL/Carrier RNA solution more than 6 times. DO NOT incubate at 80°C for more than 5 min. Frequent warming and extended incubation will cause degradation of the carrier RNA, leading to reduced recovery of viral RNA and eventually false negative RT-PCR results, particularly when low-titer samples are used.**

## Reagents and Equipment to be Supplied by User

- Ethanol (96–100%)
- Microcentrifuge tubes (1.5-ml)
- Sterile, RNase-free pipet tips with aerosol barrier
- Disposable gloves
- Microcentrifuge (with rotor for 2-ml tubes)
- Vacuum manifold (QIAvac 6S [see ordering information, page 33] or equivalent)
- Luer adapters (see ordering information, page 33)
- VacConnectors (see ordering information, page 33)
- Vacuum pump capable of producing a vacuum of –800 to –900 mbar (e.g. KN Neuberger Laboport type N 840.3 FT 18)
- Vacuum regulator (see ordering information, page 33)

## Product Use Limitations

QIAamp Kits are intended as general-purpose devices. No claim or representation is intended for their use to identify any specific organism or for clinical use (diagnostic, prognostic, therapeutic, or blood banking). It is the user's responsibility to validate the performance of QIAamp Kits for any particular use, since the performance characteristics of these kits have not been validated for any specific organism. QIAamp Kits may be used in clinical diagnostic laboratory systems after the laboratory has validated their complete system as required by CLIA '88 regulations in the U.S. or equivalents in other countries. All due care and attention should be exercised in the handling of the products. We recommend all users of QIAamp products to adhere to the NIH guidelines that have been developed for recombinant DNA experiments, or to other applicable guidelines.

## Product Warranty and Satisfaction Guarantee

QIAGEN guarantees the performance of all products in the manner described in our product literature. The purchaser must determine the suitability of the product for its particular use. Should any product fail to perform satisfactorily due to any reason other than misuse, QIAGEN will replace it free of charge or refund the purchase price. We reserve the right to change, alter, or modify any product to enhance its performance and design. If QIAGEN product does not meet your expectations, simply call your local Technical Service Department. We will credit your account or exchange the product — as you wish. A copy of QIAGEN terms and conditions can be obtained on request, and is also provided on the back of our invoices. If you have questions about product specifications or performance, please call QIAGEN Technical Services or your local distributor.

## Technical Assistance

At QIAGEN we pride ourselves on the quality and availability of our technical support. Our Technical Service Departments are staffed by experienced scientists with extensive practical and theoretical expertise in molecular biology and the use of QIAGEN products. If you have any questions or experience any difficulties regarding QIAamp Viral RNA Mini Kits or QIAGEN products in general, please do not hesitate to contact us. QIAGEN customers are a major source of information regarding advanced or specialized uses of our products. This information is helpful to other scientists as well as to the researchers at QIAGEN. We therefore encourage you to contact us if you have any suggestions about product performance or new applications and techniques. For technical assistance and more information please call one of the QIAGEN Technical Service Departments or contact your local distributor listed on the last page.

## The QIAamp Principle and Procedure

Please take a few moments to read this handbook carefully before beginning your preparation. The "Important Notes Before Starting" on page 14, and the comments with the QIAamp Viral RNA Mini protocols, beginning on page 18, are particularly valuable. QIAamp Viral RNA Mini Kits represent a well established general-purpose technology for viral RNA preparation. The kit combines the selective binding properties of a silica-gel-based membrane with the speed of microspin or vacuum technology and is ideally suited for simultaneous processing of multiple samples. The sample is first lysed under high denaturing conditions to inactivate RNases and to ensure isolation of intact viral RNA. Buffering conditions are then adjusted to provide optimum binding of the RNA to the QIAamp membrane, and the sample is loaded onto the QIAamp spin column. The RNA binds to the membrane, and contaminants are efficiently washed away in two steps using two different wash buffers. High-quality RNA is eluted in a special RNase-free buffer, ready for direct use or safe storage. The purified RNA is free of protein, nucleases, and other contaminants and inhibitors. The special QIAamp membrane guarantees extremely high recovery of pure, intact RNA in just twenty minutes without the use of phenol/chloroform extraction or alcohol precipitation. All buffers and reagents are guaranteed to be RNase-free. QIAamp Viral RNA Mini Kits provide the fastest and easiest way to purify viral RNA for reliable use in amplification technologies. Viral RNA can be purified from plasma (untreated or treated with anticoagulants other than heparin), serum, and other cell-free body fluids. Samples may be fresh or frozen, but if frozen, should not be thawed more than once. Repeated freeze-thawing of plasma samples will lead to reduced viral titers and should be avoided for optimal sensitivity. Cryoprecipitates accumulate when samples are subjected to repeated freeze-thawing cycles. This may lead to clogging of the QIAamp membrane when using the vacuum protocol.

QIAamp Viral RNA Mini Kits are general purpose kits which can be used for isolation of viral RNA from a wide variety of viruses including HIV, HAV, HCV, HDV, and enteroviruses, but performance can not be guaranteed for every virus.

### Cellular DNA contamination

QIAamp Kits are not designed to separate viral RNA from cellular DNA, and both will be purified in parallel if present in the sample. To avoid copurification of cellular DNA, use of cell-free body fluids for preparation of viral RNA is recommended. Samples containing cells, such as cerebrospinal fluid, bone marrow, urine, and most swabs, should first be filtered, or centrifuged for 10 minutes at 1500 x g and the supernatant used. If RNA or DNA have been isolated in parallel, the eluate can be DNase digested using RNase-free DNase, followed by heat treatment (15 min, 70°C) to inactivate the DNase.

## Warnings and precautions

RNA is extremely sensitive to RNases and should always be prepared with due care. Hands and dust particles may carry bacteria and molds and are the most common sources of RNase contamination. Please read "Handling RNA" in the Appendix (page 29) of this handbook before starting.

PCR should always be carried out using good laboratory practices. Accordingly, a PCR laboratory should always be divided into three areas: an area for preparation of reagents, an area for preparation of samples, and an area for amplification and detection. Due to the high sensitivity of PCR, it is absolutely necessary that all reagents remain pure and uncontaminated, and should be monitored carefully and routinely. Contaminated reagents must be discarded.

## Sample volumes

QIAamp spin columns can bind RNA greater than 200 nucleotides in length. Actual yield will depend on sample size, sample storage, and virus titer. The procedure is optimized for use with 140- $\mu$ l samples, but samples up to 280  $\mu$ l can be used. Small samples should be adjusted to 140  $\mu$ l with phosphate-buffered saline (PBS) before loading, and samples with a low viral titer should be concentrated to 140  $\mu$ l before processing. For samples larger than 140  $\mu$ l, the amount of lysis buffer and other reagents added to the sample before loading must be increased proportionally, but the amounts of Buffers AW1 and AW2 used in the wash steps usually do not need to be increased. Follow the special "Protocol for Large Sample Volumes," page 23. If the initial sample volume is increased, application of the lysed sample to the QIAamp spin column will require multiple loading steps. There is no danger of overloading the QIAamp spin column, and the quality of the purified RNA will be unaffected. For volumes greater than 560  $\mu$ l, concentration of the sample is recommended. See "Protocol for Sample Concentration," page 24.

## Lysis

The sample is first lysed under the highly denaturing conditions provided by Buffer AVL to inactivate RNases and to ensure isolation of intact viral RNA. Carrier RNA, added to Buffer AVL, improves the binding of viral RNA to the QIAamp membrane especially in the case of low-titer samples, and limits possible degradation of the viral RNA due to any residual RNase activity.

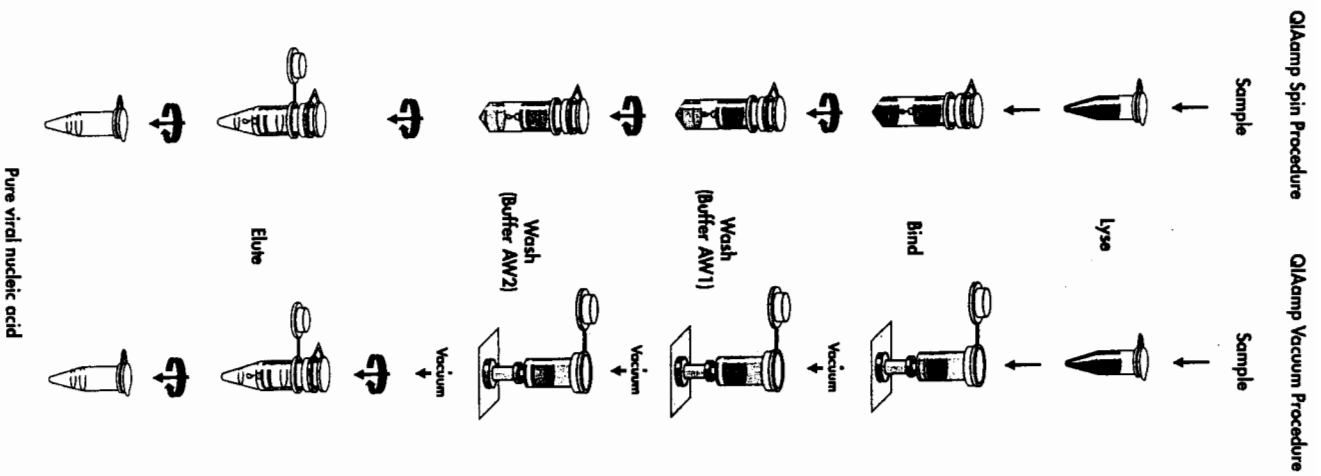

Figure 1. QIAamp Viral RNA Mini spin and vacuum procedures

## QIAamp spin-column procedure

The QIAamp Viral RNA Mini purification procedure is carried out in three steps using QIAamp spin columns in a standard microcentrifuge or on a vacuum manifold. Both spin and vacuum procedures are designed to ensure that there is no sample-to-sample cross-contamination and allow safe handling of potentially infectious samples.

QIAamp spin columns fit into most standard microcentrifuge tubes. In the spin protocol, due to the volume of filtrate, 2-ml collection tubes (provided) are required to support the QIAamp spin column during loading and wash steps. For the vacuum protocol, a vacuum manifold (QIAvac 6S or similar) and a vacuum pump capable of producing a vacuum of -800 to -900 mbar (e.g. KMS Neuberger Laboport type N 840.3 FT 18) are required. Eluted RNA can be collected in standard 1.5-ml microcentrifuge tubes (not provided). These tubes must be RNase-free to avoid degradation of viral RNA by RNases.

### Adsorption to the QIAamp membrane

The buffering conditions of the lysate must be adjusted to provide optimum binding conditions for the viral RNA before loading the sample onto the QIAamp spin column. Viral RNA is adsorbed onto the QIAamp silica-gel membrane during two brief centrifugation steps or by vacuum. Salt and pH conditions in the lysate ensure that protein and other contaminants, which can inhibit downstream enzymatic reactions, are not retained on the QIAamp membrane. If the initial sample volume is larger than 140  $\mu$ l, it will be necessary to load the lysate onto the QIAamp spin column in several steps.

### Removal of residual contaminants

Viral RNA, bound to the QIAamp membrane, is washed free of contaminants during two short centrifugation or vacuum steps. The use of two different wash buffers, AW1 and AW2, has significantly improved the purity of the eluted RNA. Wash conditions ensure complete removal of any residual contaminants without affecting RNA binding.

### Elution with Buffer AVE

Buffer AVE is RNase-free water that contains 0.04% sodium azide to prevent microbial growth and subsequent contamination with RNases. Sodium azide affects spectrophotometric absorbance readings between 220 and 280 nm but has no effect on downstream applications, such as RT-PCR. Should you wish to determine the purity of the eluted RNA, elution with RNase-free water instead of Buffer AVE is recommended.

## Determination of yield

Yields of viral RNA isolated from biological samples are normally less than 1  $\mu$ g and therefore difficult to determine photometrically. Keep in mind that the carrier RNA (5.6  $\mu$ g per 1  $\mu$ l sample) will account for most of the RNA present. Quantitative RT-PCR is recommended for determination of viral RNA yield.

## Determination of viral RNA length

The size distribution of viral RNA purified using QIAamp spin columns can be checked by denaturing agarose gel electrophoresis followed by hybridization with a virus-specific labeled probe and autoradiography (1).

1. Sambrook, J., Fritsch, E.F., Maniatis, T., eds. (1989) *Molecular cloning: a laboratory manual*, 2nd ed. New York: Cold Spring Harbor Laboratory Press.

## QIAvac 6S Vacuum Manifold

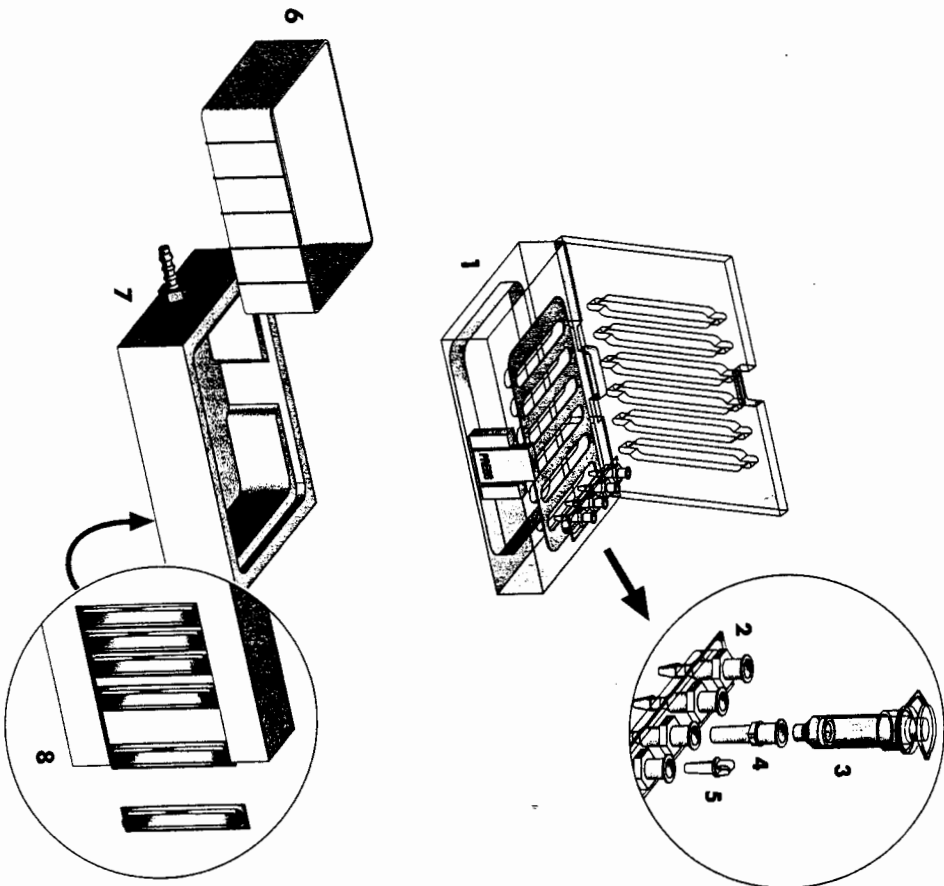

**Figure 2.** Exploded diagram of QIAvac 6S manifold and components

1. QIAvac top plate with slots for QIAvac Luer Adapters
  2. QIAvac Luer Adapter\*
  3. QIAamp mini spin column
  4. VacConnector\*
  5. Plug to seal unused luer connectors\*
  6. Waste tray
  7. QIAvac base, which can hold a waste tray or a microtube rack
  8. Blanks to seal unused slots
- \* Not included — must be purchased separately

## QIAvac 6S handling guidelines

The QIAvac 6S vacuum manifold facilitates RNA purification with QIAamp Viral RNA Mini Kits. In combination with QIAvac Luer Adapters and VacConnectors, it allows easy processing of QIAamp mini spin columns. The following recommendations should be followed when handling the QIAvac 6S vacuum manifold:

- Always store the QIAvac 6S vacuum manifold clean and dry. To clean, simply rinse all components with water, and dry with paper towels. Do not air-dry, as the screws may rust. Do not use abrasives or solvents.
- Always place the QIAvac 6S vacuum manifold on a secure bench top or work area. If dropped, the manifold may crack.
- The components of QIAvac manifolds are not resistant to ethanol, methanol, or other organic solvents (Table 1). Do not bring the vacuum manifold into contact with solvents. If solvents are spilled on the unit, rinse thoroughly with distilled water. Do not incubate acrylic components in alcohol-containing reagents for long periods.
- To ensure consistent performance, do not apply silicone or vacuum grease to any part of the QIAvac 6S manifold. The spring lock on the top plate and the self-sealing gasket provide an airtight seal when vacuum is applied to the assembled unit. To maximize gasket lifetime, rinse the gasket free of salts and buffers after each use, and dry with paper towels before storage.

**Table 1.** Chemical resistance properties of QIAvac manifolds

Resistant to:	Not resistant to:	
Chlorine bleach (12%)	Acetic acid	Concentrated alcohols
Hydrochloric acid	Acetone	Ether
Sodium chloride	Benzene	Phenol
Sodium hydroxide	Chloroform	Toluene
Urea	Chromic acid	



## Important Notes Before Starting

If preparing RNA for the first time please read "Handling RNA" in the Appendix of this handbook (page 29). All steps of the QIAamp Viral RNA Mini protocols should be performed quickly and at room temperature.

After collection and centrifugation, plasma (untreated or treated with anticoagulants other than heparin) or serum can be stored at 2–8°C for up to 6 hours. For long-term storage, freezing at –20°C to –80°C in aliquots is recommended. Frozen plasma or serum samples must not be thawed more than once. Repeated freezing and thawing leads to denaturation and precipitation of proteins, causing reduced viral titers and subsequently reduced yields of the isolated viral RNA. In addition, cryoprecipitates formed by freeze-thawing will cause clogging of the QIAamp membrane. If cryoprecipitates are visible, they can be pelleted by briefly centrifuging at 6800 x g for 3 minutes. The cleared supernatant should be removed, without disturbing the pellet, and processed immediately. This step will not reduce viral titers.

The QIAamp procedure is not designed to separate RNA from DNA. To avoid cellular DNA contamination follow the guidelines in "Cellular DNA contamination" on page 7 of this handbook.

The QIAamp Viral RNA procedure isolates all RNA molecules larger than 200 nucleotides. Smaller RNA molecules will not bind quantitatively under the conditions used.

### Preparation of reagents

#### Addition of Carrier RNA to Buffer AVL\*

Check Buffer AVL for precipitate, and if necessary incubate at 80°C until the precipitate is dissolved.

Add 1 ml of Buffer AVL to one tube of lyophilized Carrier RNA. Dissolve Carrier RNA thoroughly. Transfer to the Buffer AVL bottle, and mix thoroughly before using Buffer AVL for the first time.

**Note:** If less Carrier RNA has been shown to be better for your particular amplification system, add 1 ml of Buffer AVL to one tube of lyophilized Carrier RNA, as described above, and transfer only the required aliquot to the Buffer AVL bottle. For example, if 1 µg Carrier RNA per ml of Buffer AVL has been shown to provide optimal RT-PCR efficiency, transfer 100 µl of reconstituted Carrier RNA to the Buffer AVL bottle. Discard the unused portion of the reconstituted Carrier RNA.

\* Contains chaotropic salt which is an irritant. Take appropriate laboratory safety measures, and wear gloves when handling. Not compatible with disinfecting agents that contain bleach.

Lyophilized Carrier RNA is stable for up to 1 year when stored at room temperature (15–25°C). Carrier RNA dissolved in Buffer AVL, however, should be stored at 2–8°C. It will be stable for up to 6 months. If Buffer AVL/Carrier RNA is stored at room temperature it will be stable for no more than 2 weeks. When stored at 2–8°C, the Buffer AVL/Carrier RNA solution forms a precipitate; this precipitate must be redissolved by warming at 80°C and the solution cooled to room temperature before use.

Do not warm Buffer AVL/Carrier RNA solution more than 6 times. DO NOT incubate at 80°C for more than 5 min. Frequent warming and extended incubation will cause degradation of Carrier RNA, leading to reduced recovery of viral RNA and eventually to negative RT-PCR results. This is particularly the case with low-titer samples.

#### Buffer AW1\*

Buffer AW1 is supplied as a concentrate. Before using for the first time, add appropriate amount of ethanol (96–100%) as indicated on the bottle and in Table 2. Buffer AW1 is stable for 1 year when stored closed at room temperature.

Table 2. Preparation of Buffer AW1

Kit Cat. No.	No. of preps	AW1 concentrate	Ethanol	Final volume
51104	50	19 ml	25 ml	44 ml
51106	250	95 ml	125 ml	220 ml
51108	1000	175 ml	230 ml	405 ml

#### Buffer AW2†

Buffer AW2 is supplied as a concentrate. Before using for the first time, add the appropriate amount of ethanol (96–100%) to Buffer AW2 concentrate as indicated on the bottle and in Table 3.

Buffer AW2 is stable for 1 year when stored closed at room temperature.

Table 3. Preparation of Buffer AW2

Kit Cat. No.	No. of preps	AW2 concentrate	Ethanol	Final volume
51104	50	13 ml	30 ml	43 ml
51106	250	66 ml	160 ml	226 ml
51108	1000	127 ml	300 ml	427 ml

\* Contains chaotropic salt which is an irritant. Take appropriate laboratory safety measures, and wear gloves when handling. Not compatible with disinfecting agents that contain bleach.

† Contains sodium azide as a preservative. Sodium azide is highly toxic and may react explosively with lead and copper drain pipes. Take appropriate safety measures, and wear gloves when handling. Dispose of azide containing solutions according to your institutions waste-disposal guidelines.

## Handling of QIAamp spin columns

Owing to the sensitivity of nucleic acid amplification technologies, the following precautions are necessary when handling QIAamp spin columns to avoid cross-contamination between sample preparations:

- Carefully apply the sample or solution to the QIAamp spin column. Pipet the sample into the QIAamp spin column without wetting the rim of the column.
- Change pipet tips between all liquid transfer steps. The use of aerosol-barrier tips is recommended.
- Avoid touching the QIAamp membrane with the pipet tip.
- After all pulse-vortexing steps, briefly centrifuge 1.5-ml microcentrifuge tubes to remove drops from the inside of the lid.
- Wear gloves throughout the procedure. In case of contact between gloves and sample, change gloves immediately.

### Spin protocol

- Close the QIAamp spin column before placing it in the microcentrifuge. Centrifuge as described.
- Remove the QIAamp spin column and collection tube from the microcentrifuge. Place the QIAamp spin column in a new collection tube. Discard the filtrate and the old collection tube. Please note that the filtrate may contain hazardous waste and should be disposed of properly.
- Open only one QIAamp spin column at a time, and take care to avoid generating aerosols.
- For efficient parallel processing of multiple samples, it is recommended to fill a rack with collection tubes to which the QIAamp spin columns can be transferred after centrifugation. Used collection tubes containing the filtrate can be discarded, and the new collection tubes containing the QIAamp spin columns can be placed directly in the microcentrifuge.

### Vacuum protocol

- Insert new VacConnectors into the Luer connectors on the Luer Adapters in the manifold (see Figure 2, page 12). Remove the QIAamp spin columns from the blister pack and attach spin column to the VacConnector. The collection tube can be saved for the dry spin in step 10 of the protocol. Used VacConnectors should be discarded.
- The vacuum pressure is the pressure difference between the inside of the manifold and the atmosphere (standard atmospheric pressure 1013 millibar) and can be measured using a vacuum regulator (see ordering information on page 33). The vacuum protocol requires a vacuum pump capable of producing a vacuum of -800 to -900 mbar (e.g. KMS Neuberger Laboport type N 840.3 FT 18). Higher vacuum pressures must be avoided. Use of vacuum pressures lower than recommended may reduce DNA yield and purity.
- Switch off vacuum between steps to ensure that a consistent, even vacuum is applied during manipulations.
- Wear safety glasses when working near a manifold under pressure.
- Leave the lid of the QIAamp spin column open while applying vacuum.

### Centrifugation

QIAamp spin columns will fit into most standard 1.5- or 2-ml microcentrifuge tubes. Additional 2-ml collection tubes are available separately.

Centrifugation of QIAamp spin columns is performed at 6000 x g (8000 rpm) in order to limit centrifuge noise. Centrifugation at full speed will not affect RNA yield. Centrifugation at lower speeds for lysate loading and the first wash step is also acceptable, provided that the complete solution is transferred through the membrane. At the second wash step centrifugation at full speed is strongly recommended.

All centrifugation steps are carried out at room temperature.

## QIAamp Viral RNA Mini Spin Protocol

Notes: Please read "Important Notes Before Starting" on pages 14–17.

- Equilibrate samples to room temperature (15–25°C).
  - Equilibrate Buffer AVE to room temperature for elution in step 10.
  - Check that Buffer AW1, Buffer AW2, and Carrier RNA have been prepared according to the instructions on pages 14–15.
  - Redissolve precipitate in Buffer AVL/Carrier RNA by heating, if necessary, and cool to room temperature before use.
  - All centrifugation steps are carried out at room temperature.
1. **Pipet 560 µl of prepared Buffer AVL containing Carrier RNA into a 1.5-ml microcentrifuge tube.**
    - If the sample volume is larger than 140 µl, increase the amount of Buffer AVL/Carrier RNA proportionally (e.g., a 280-µl sample will require 1120 µl Buffer AVL/Carrier RNA).
  2. **Add 140 µl plasma, serum, urine, cell-culture supernatant, or cell-free body fluid to the Buffer AVL/Carrier RNA in the microcentrifuge tube. Mix by pulse-vortexing for 15 sec.**

To ensure efficient lysis, it is essential that the sample is mixed thoroughly with Buffer AVL to yield a homogeneous solution. Frozen samples that have only been thawed once can also be used.
  3. **Incubate at room temperature (15–25°C) for 10 min.**

Viral particle lysis is complete after lysis for 10 min at room temperature. Longer incubation times have no effect on the yield or quality of the purified RNA. Potentially infectious agents and RNases are inactivated in Buffer AVL.
  4. **Briefly centrifuge the 1.5-ml microcentrifuge tube to remove drops from the inside of the lid.**
  5. **Add 560 µl of ethanol (96–100%) to the sample, and mix by pulse-vortexing for 15 sec. After mixing, briefly centrifuge the 1.5-ml microcentrifuge tube to remove drops from inside the lid.**

Only ethanol should be used since other alcohols may result in reduced RNA yield and purity. If the sample volume is greater than 140 µl, increase the amount of ethanol proportionally (e.g., a 280-µl sample will require 1120 µl of ethanol). In order to ensure efficient binding, it is essential that the sample is mixed thoroughly with the ethanol to yield a homogeneous solution.
  6. **Carefully apply 630 µl of the solution from step 5 to the QIAamp spin column (in a 2-ml collection tube) without wetting the rim. Close the cap, and centrifuge at 6000 x g (8000 rpm) for 1 min. Place the QIAamp spin column into a clean 2-ml collection tube, and discard the tube containing the filtrate.**

Close each spin column in order to avoid cross-contamination during centrifugation. Centrifugation is performed at 6000 x g (8000 rpm) in order to limit microcentrifuging noise. Centrifugation at full speed will not affect the yield or purity of the viral RNA. If the solution has not completely passed through the membrane, centrifuge again at a higher speed until all of the solution has passed through.

7. **Carefully open the QIAamp spin column, and repeat step 6.**

If the sample volume was greater than 140 µl, repeat this step until all of the lysate has been loaded onto the spin column.
8. **Carefully open the QIAamp spin column, and add 500 µl of Buffer AW1. Close the cap, and centrifuge at 6000 x g (8000 rpm) for 1 min. Place the QIAamp spin column in a clean 2-ml collection tube (provided), and discard the tube containing the filtrate.**

It is not necessary to increase the volume of Buffer AW1 even if the original sample volume was larger than 140 µl.
9. **Carefully open the QIAamp spin column, and add 500 µl of Buffer AW2. Close the cap and centrifuge at full speed (20,000 x g; 14,000 rpm) for 3 min. Continue directly with step 10, or to eliminate any chance of possible Buffer AW2 carryover, perform step 9a, and then continue with step 10.**

**Note:** Residual Buffer AW2 in the eluate may cause problems in downstream applications. Some centrifuge rotors may vibrate upon deceleration, resulting in flow-through, containing Buffer AW2, contacting the QIAamp spin column. Remove the QIAamp spin column and collection tube from the rotor may also cause the flow-through to come into contact with the QIAamp spin column. In these cases, the optional step 9a should be performed.
- 9a. **(Optional): Place the QIAamp spin column in a new 2-ml collection tube (not provided) and discard the old collection tube with the filtrate. Centrifuge at full speed for 1 min.**
10. **Place the QIAamp spin column in a clean 1.5-ml microcentrifuge tube (not provided). Discard the old collection tube containing the filtrate. Carefully open the QIAamp spin column and add 60 µl of Buffer AVE equilibrated to room temperature. Close the cap, and incubate at room temperature for 1 min. Centrifuge at 6000 x g (8000 rpm) for 1 min.**

A single elution with 60 µl of Buffer AVE is sufficient to elute at least 90% of the viral RNA from the QIAamp spin column. Performing a double elution using 2 x 40 µl of Buffer AVE will increase yield by up to 10%. Elution with volumes of less than 30 µl will lead to reduced yields and will not increase the final concentration of RNA in the eluate.

Viral RNA is stable for up to one year when stored at –20°C or –70°C.

## QIAamp Viral RNA Mini Vacuum Protocol

**Notes:** Please read "Important Notes Before Starting" on pages 14-17.

- Equilibrate samples to room temperature (15–25°C).
  - Equilibrate Buffer AVE to room temperature for elution in step 11.
  - Check that Buffers AW1 and AW2, and Carrier RNA have been prepared according to instructions (see pages 14–15).
  - Redissolve precipitate in Buffer AVL/Carrier RNA by heating, if necessary, and cool to room temperature before use.
  - Connect the QIAvac 6S vacuum manifold (see Figure 2, page 12) to the vacuum pump and open the QIAvac 6S lid. Place QIAvac Luer Adapters (or blanks to seal unused slots) into the slots of the QIAvac top plate and close the QIAvac 6S lid. Place the waste tray inside the QIAvac 6S base and place the top plate squarely over the base. Insert a VacConnector into the Luer connectors of the Luer Adapter(s) in the vacuum manifold. Seal unused Luer connectors with the plugs provided in the QIAvac Luer Adapter Set.
  - Switch off the vacuum between protocol steps to ensure that a consistent, even vacuum is applied during each step.
  - All centrifugation steps are carried out at room temperature.
1. **Pipet 560 µl of prepared Buffer AVL containing Carrier RNA into a 1.5-ml micro-centrifuge tube.**  
If the sample volume is larger than 140 µl, increase the amount of Buffer AVL/Carrier RNA proportionally (e.g., a 280-µl sample will require 1120 µl Buffer AVL/Carrier RNA).
  2. **Add 140 µl plasma, serum, urine, cell-culture supernatant, or cell-free body fluid to the Buffer AVL/Carrier RNA in the microcentrifuge tube. Mix by pulse-vortexing for 15 sec.**  
To ensure efficient lysis, it is essential that the sample is mixed thoroughly with Buffer AVL to yield a homogeneous solution. Frozen samples that have only been thawed once can also be used.
  3. **Incubate at room temperature (15–25°C) for 10 min.**  
Viral particle lysis is complete after lysis for 10 min at room temperature. Longer incubation times have no effect on the yield or quality of the purified RNA. Potentially infectious agents and RNases are inactivated in Buffer AVL.
  4. **Briefly centrifuge the 1.5-ml microcentrifuge tube to remove drops from the inside of the lid.**

5. **Add 560 µl of ethanol (96–100%) to the sample, and mix by pulse-vortexing for 15 sec.** After mixing, briefly centrifuge the 1.5-ml microcentrifuge tube to remove drops from inside the lid. Insert a QIAamp spin column into the VacConnector on the QIAvac 6S vacuum manifold.

Only ethanol should be used since other alcohols may result in reduced yield and purity of the RNA. If the sample volume is greater than 140 µl, increase the amount of ethanol proportionally (e.g., a 280-µl sample will require 1120 µl of ethanol). In order to ensure efficient binding, it is essential that the sample is mixed thoroughly with the ethanol to yield a homogeneous solution.

6. **Carefully apply 630 µl of the solution from step 5 to the QIAamp spin column without wetting the rim. Switch on the vacuum pump. Be sure to leave the lid of the QIAamp spin column open while applying vacuum. After all lysates have been drawn through the spin column, switch off the vacuum pump.**

If at this stage all of the solution has not passed through the membrane, place the QIAamp spin column into a clean 2-ml collection tube (provided), close the cap, and centrifuge at 6000 x g (8000 rpm) for 3 min or until it has completely passed through. Place the QIAamp spin column into another clean 2-ml collection tube, and discard the tube containing the filtrate. Continue with step 7 of the spin protocol on page 19. Centrifugation is performed at 6000 x g (8000 rpm) in order to limit centrifuge noise. Centrifugation at full speed will not affect the yield or purity of viral RNA.

7. **Repeat step 6.**  
If the sample volume was higher than 140 µl, repeat this step until all of the lysate has been drawn through the spin column.
8. **Carefully add 750 µl of Buffer AW1 to the QIAamp spin column, and switch on the vacuum pump. Do not wet the rim of the spin column. After all of Buffer AW1 has been drawn through the spin column, switch off the vacuum pump.**
9. **Carefully add 750 µl of Buffer AW2 to the QIAamp spin column, and switch on the vacuum pump. Do not wet the rim of the spin column. After all of Buffer AW2 has been drawn through the spin column, switch off the vacuum pump.**
10. **Close the lid of the QIAamp spin column, remove it from the vacuum manifold, and discard the VacConnector. Place the QIAamp spin column into a clean 2-ml collection tube, and centrifuge at full speed for 1 min to dry the membrane completely.**

11. Place the QIAamp spin column into a clean 1.5-ml microcentrifuge tube (not provided). Discard the collection tube containing the filtrate. Carefully open the QIAamp spin column. Add 60  $\mu$ l of Buffer AVE equilibrated to room temperature. Close the cap, and incubate at room temperature for 1 min. Centrifuge at 6000  $\times$  g (8000 rpm) for 1 min.
- A single elution with 60  $\mu$ l of Buffer AVE is sufficient to elute at least 90% of the viral RNA from the QIAamp spin column. Performing a double elution using 2  $\times$  40  $\mu$ l of Buffer AVE will increase yield by up to 10%. Elution with volumes of less than 30  $\mu$ l will lead to reduced yields and will not increase the final concentration of RNA in the eluate.
- Viral RNA is stable for up to one year when stored at  $-20^{\circ}\text{C}$  or  $-70^{\circ}\text{C}$ .

## Protocol for Large Sample Volumes

Samples of up to 560  $\mu$ l can be processed with the QIAamp Viral RNA Mini Kit using the protocol.

1. Pipet sample into a 5-ml microcentrifuge tube. Use up to 560  $\mu$ l of fresh plasma, serum, cell-culture supernatant, or cell-free body fluids. Up to 560  $\mu$ l of frozen sample (thawed only once) can also be used. Sample volume should always be a multiple of 140  $\mu$ l.
2. Add 560  $\mu$ l Buffer AVL/Carrier RNA [prepared as described on page 14] per 140  $\mu$ l of sample. Mix thoroughly by vortexing.
3. Incubate at room temperature (15–25 $^{\circ}\text{C}$ ) for 10 min.
4. Add 560  $\mu$ l of ethanol (96–100%) per 140  $\mu$ l of initial sample volume, and mix again by vortexing.
5. Apply 630  $\mu$ l of the lysate to the QIAamp spin column. Centrifuge 1 min at 6000  $\times$  (8000 rpm), discard the filtrate.
6. Repeat step 5 until the entire lysate has been loaded onto the column. A maximum of 8  $\times$  630  $\mu$ l can be loaded onto the QIAamp spin column.
7. Place QIAamp spin column in a clean 2-ml collection tube.
8. Follow the QIAamp Viral RNA Mini Spin Protocol from step 8 (page 14).

## Protocol for Sample Concentration

Plasma, serum, urine, cerebrospinal fluid, bone marrow, and other body fluids often have very low viral titers. In these cases, concentrating samples of up to 3.5 ml to a final volume of 140  $\mu$ l is recommended.

1. Use centrifugal microconcentrators such as Centricore® 100 (Amicon: 2 ml, Cat. No. 4211), Microsep 100 (Filtron: 3.5 ml, Cat. No. OD100C40), Ultrafree®-CL (Millipore: 2 ml, Cat. No. UFC4 THK 25), or equivalent from other suppliers.
2. Apply up to 3.5 ml of sample to the microconcentrator following the manufacturer's instructions.
3. Centrifuge according to manufacturer's instructions to a final volume of 140  $\mu$ l. Some samples, plasma in particular, may be difficult to concentrate to 140  $\mu$ l due to high viscosity. Centrifugation for up to 6 hours may be necessary.
4. Pipet 140  $\mu$ l of concentrated sample into a 1.5-ml microcentrifuge tube, and follow the QIAamp Viral RNA Mini Spin Protocol on page 18.

## Protocol for Isolation of Cellular, Bacterial, or Viral DNA from Urine

Buffer AVL, used in the QIAamp Viral RNA Mini procedure, inactivates the numerous unidentified PCR inhibitors found in urine. Therefore, for isolation of cellular, bacterial, or viral DNA from urine for use in PCR the QIAamp Viral RNA Mini Spin Protocol (page 18) is recommended.

Urine often contains very low numbers of cells, bacteria, or viruses. In these cases, we recommend concentrating samples of up to 3.5 ml to a final volume of 140  $\mu$ l, as described in the "Protocol for Sample Concentration" on page 24, before processing.

For isolation of DNA from Gram-positive bacteria, please contact QIAGEN Technical Services

# Troubleshooting Guide

## Comments and suggestions

- Little or no RNA in the eluate**
- a) Carrier RNA not added to Buffer AVL and repeat the purification procedure with a new sample.
  - b) Degraded carrier RNA  
Buffer AVL/Carrier RNA was warmed more than 6 times or incubated for more than 5 min at 80°C. Prepare a new bottle of Buffer AVL/Carrier RNA according to the instructions on page 14, and repeat the purification procedure with a new sample.
  - c) Sample frozen and thawed Repeated freezing and thawing should be avoided. Always use fresh samples or samples thawed only once.
  - d) Low concentration of virus Concentrate the sample volume to 140 µl using a micro-concentrator. Repeat the RNA purification procedure with a new sample. See "Protocol for Sample Concentration" on page 24.
  - e) Inefficient protein denaturation in Buffer AVL  
Precipitate, formed in Buffer AVL/Carrier RNA after storage at 2–8°C, was not redissolved by heating before starting the procedure. Redissolve the precipitate, and repeat the procedure with a new sample.
  - f) Buffer AVL prepared incorrectly  
Check Buffer AVL for precipitate. Dissolve precipitate by incubation at 80°C.
  - g) No ethanol added to the lysate (step 5)  
Repeat the purification procedure with a new sample.
  - h) Low percentage ethanol used  
Repeat the purification procedure with a new sample. Use 96–100% ethanol in step 5.
  - i) Isopropanol used instead of ethanol  
We strictly recommend the use of ethanol as isopropanol causes reduced yields.
  - j) RNA degraded  
Often RNA is degraded by RNases in the starting material (plasma, serum, body fluids). Ensure that the samples are processed quickly. If necessary, add RNase inhibitor to the sample. Check for RNase contamination of buffers and water, and ensure that no RNase is introduced during the procedure.
  - k) RNase contamination in Buffer AVE  
Discard contaminated Buffer AVE. Repeat the purification procedure with a new sample and a fresh tube of Buffer AVE.

## Comments and suggestions

- l) Buffer AW1 or AW2 prepared incorrectly  
Check that Buffer AW1 and AW2 concentrates were diluted with correct volumes of pure (96–100%) ethanol. Repeat the purification procedure with a new sample.
  - m) Buffer AW1 or AW2 prepared with 70% ethanol  
Check that Buffer AW1 and AW2 concentrates were diluted with 96–100% ethanol. Repeat the purification procedure with a new sample.
  - n) Buffers AW1 and AW2 used in the wrong order  
Ensure that Buffer AW1 and Buffer AW2 are used in the correct order in the protocol. Repeat the purification procedure with a new sample.
- RNA does not perform well in subsequent enzymatic reactions**
- a) Little or no RNA in the eluate  
Check "Little or no RNA in the eluate," above, for possible reasons.
  - b) Inefficient virus lysis in Buffer AVL  
Precipitate formed in Buffer AVL/Carrier RNA due temperature change before start of process. Repeat the procedure with new samples, and ensure that precipitate has formed in Buffer AVL/Carrier RNA at the beginning of the process.
  - c) Buffer AVL prepared incorrectly  
Ensure that Carrier RNA has been added to Buffer AVL.
  - d) Too much Carrier RNA in the eluate  
Determine the maximum amount of Carrier RNA suitable for your RT-PCR. Adjust the concentration of Carrier RNA added to Buffer AVL accordingly.
  - e) Reduced sensitivity  
Determine the maximum volume of eluate suitable for your RT-PCR. Reduce the volume of eluate added to the RT-PCR.
  - f) Buffers AW1 and AW2 used in the wrong order  
Ensure that Buffer AW1 and Buffer AW2 are used in the correct order in the protocol. Repeat the purification procedure with a new sample.
  - g) New combination of reverse transcriptase and Taq DNA polymerase used  
If enzymes are changed, it may be necessary to readjust the amount of Carrier RNA added to Buffer AVL.

### DNA contamination

DNA and RNA present in the sample

To avoid copurification of DNA, use of cell-free body fluids for preparation of viral RNA is recommended. Samples containing cells, such as cerebrospinal fluid, bone marrow, urine, and most swabs, should be made cell-free by centrifugation or filtration. If using centrifugation, pellet the cells for 10 min at 1500 x g and use supernatant for isolation of viral RNA. If DNA-free RNA is required, digest either the sample or the eluate with RNase-free DNase. DNase in the eluate must be inactivated by heat treatment (15 min, 70°C).

### General handling

- a) Lysate not completely passed through the membrane

Using spin protocol: Centrifuge for 1 min at full speed or until all the lysate has passed through the membrane.

Using vacuum protocol: Insufficient vacuum was applied or the lid of the spin column was closed during the vacuum step. Increase the vacuum, and open the lid while applying the vacuum. If the vacuum pressure cannot be increased, place the QIAamp spin column in a clean 2-ml collection tube, close the cap, and centrifuge at 6000 x g (8000 rpm) for 3 min or until the lysate has completely passed through the membrane. Place the QIAamp spin column into another clean 2-ml collection tube, and discard the tube containing the filtrate. Continue with step 7 of the spin protocol on page 19.

- b) Clogged membrane

Cryoprecipitates have formed in plasma due to repeated freezing and thawing. Do not use plasma that has been frozen and thawed more than once.

- c) Cross-contamination between samples

To avoid cross-contamination when handling QIAamp spin columns follow the guidelines in "Handling of QIAamp spin columns" on page 16. Repeat the purification procedure with new samples.

- d) Vacuum pressure too high/too low

Using a vacuum pressure that is too high may damage the QIAamp membrane. Using a vacuum pressure which is too low may cause reduced DNA yield and purity. Use a vacuum regulator (see ordering information on page 33) to adjust the pressure to -800 to -900 mbar for all vacuum steps.

## Appendix

### Handling RNA

Ribonucleases (RNases) are very stable and active enzymes that generally do not require cofactors to function. Since RNases are difficult to inactivate and only minute amounts are sufficient to destroy RNA, do not use any plasticware or glassware without first eliminating possible RNase contamination. Great care should be taken to avoid inadvertently introducing RNases into the RNA sample during or after the isolation procedure. In order to create and maintain an RNase-free environment, the following precautions must be taken during pretreatment and use of disposable and non-disposable vessels and solutions while working with RNA.

### General handling

Proper microbiological, aseptic technique should always be used when working with RNA. Hands and dust particles may carry bacteria and are the most common sources of RNase contamination. Always wear latex or vinyl gloves while handling reagents and RNA samples to prevent RNase contamination from the surface of the skin or from dusty laboratory equipment. Change gloves frequently and keep tubes closed whenever possible. During the procedure, work quickly to avoid degradation of RNA by endogenous or residual RNases.

### Disposable plasticware

The use of sterile, disposable polypropylene tubes is recommended throughout the procedure. These tubes are generally RNase-free and do not require pretreatment to inactivate RNases.

### Non-disposable plasticware

Non-disposable plasticware should be treated before use to ensure that it is RNase-free. Plasticware should be thoroughly rinsed with 0.1 M NaOH, 1 mM EDTA followed by RNase-free water (see "Solutions", page 30). Alternatively, chloroform-resistant plasticware can be rinsed with chloroform to inactivate RNases.

### Glassware

Glassware should be treated before use to ensure that it is RNase-free. Glassware used for RNA work should be cleaned with detergent, thoroughly rinsed, and oven baked >240°C for four or more hours (overnight, if more convenient) before use. Autoclaving alone will not fully inactivate many RNases. Oven baking will inactivate ribonuclease. Alternatively, glassware can be treated with DEPC\* (diethyl pyrocarbonate). Rinse it

\* DEPC is a suspected carcinogen and should be handled with great care. Wear gloves and use a fume hood when using this chemical.



glassware with 0.1% DEPC (0.1% in water) overnight (12 hours) at 37°C, and then autoclave or heat to 100°C for 15 minutes to remove residual DEPC.

**Note:** Corex® tubes should be rendered RNase-free by treatment with DEPC and not by baking. This will reduce the failure rate of this type of tube during centrifugation.

### Electrophoresis tanks

Electrophoresis tanks should be cleaned with detergent solution (e.g. 0.5% SDS), rinsed with water, dried with ethanol\*, and then filled with a solution of 3% H<sub>2</sub>O<sub>2</sub>. After 10 minutes at room temperature, the electrophoresis tanks should be rinsed thoroughly with RNase-free water.

### Solutions

Solutions (water and other solutions) should be treated with 0.1% DEPC. DEPC will react with primary amines and cannot be used directly to treat Tris buffers. DEPC is highly unstable in the presence of Tris buffers and decomposes rapidly into ethanol and CO<sub>2</sub>. When preparing Tris buffers, treat water with DEPC first, and then dissolve Tris to make the appropriate buffer.

DEPC is a strong, but not absolute, inhibitor of RNases. It is commonly used at a concentration of 0.1% to inactivate RNases on glass or plasticware or to create RNase-free solutions and water. DEPC inactivates RNases by covalent modification. Trace amounts of DEPC will modify purine residues in RNA by carboxymethylation. Carboxymethylated RNA is translated with very low efficiency in cell-free systems. However, its ability to form DNA:RNA or RNA:RNA hybrids is not seriously affected unless a large fraction of the purine residues have been modified. Residual DEPC must always be removed from solutions or vessels by autoclaving or heating to 100°C for 15 minutes.

Add 0.1 ml DEPC to 100 ml of the solution to be treated. Shake vigorously to bring the DEPC into solution, or let the solution bake for 12 hours at 37°C. Autoclave for 15 minutes to remove any trace of DEPC. It may be desirable to test water sources for the presence of contaminating RNases since many sources of distilled water are free of RNase activity.

**Note:** QIAamp Viral RNA buffers are not rendered RNase-free by DEPC treatment and are therefore free of any DEPC contamination.

\* Plastics used for some electrophoresis tanks are not resistant to ethanol. Take proper care and check the supplier's instructions.

<sup>1</sup> DEPC is a suspected carcinogen and should be handled with great care. Wear gloves and use a fume hood when using this chemical.

## Ordering Information

Product	Contents	Cat. No.
<b>QIAamp Viral RNA Mini Kits</b> — for viral RNA purification from plasma, serum, and cell-free body fluids		
QIAamp Viral RNA Mini Kit (50)	50 QIAamp Spin Columns, Carrier RNA, Buffers and Collection Tubes (2-ml)	52904
QIAamp Viral RNA Mini Kit (250)	250 QIAamp Spin Columns, Carrier RNA, Buffers and Collection Tubes (2-ml)	52906

### Related Products

**QIAamp 96 Viral RNA BioRobot Kit** — for automated, high-throughput viral RNA purification from plasma, serum, and cell-free body fluids

QIAamp 96 Viral RNA BioRobot™ Kit (12)

12 QIAamp 96 Plates, Carrier RNA, Buffers, AirPore™ Tape Sheets, Tape Pad, Square-Well Blocks, Racks with Collection Microtubes, Caps

**QIAamp RNA Blood Mini Kit** — for total RNA purification from blood and body fluids

QIAamp RNA Blood Mini Kit (20)

20 QIAamp Mini Spin Columns, 20 QIAshredder Spin Columns, Collection Tubes (1.5-ml and 2-ml), RNase-free Reagents and Buffers

QIAamp RNA Blood Mini Kit (50)

50 QIAamp Mini Spin Columns, 50 QIAshredder Spin Columns, Collection Tubes (1.5-ml and 2-ml), RNase-free Reagents and Buffers

QIAamp RNA Blood Mini Kit (250)

250 QIAamp Mini Spin Columns, 250 QIAshredder Spin Columns, Collection Tubes (1.5-ml and 2-ml), RNase-free Reagents and Buffers

\* For more information, please contact your local Technical Services Department or distributor listed on the last page of this handbook.

## Ordering Information

Product	Contents	Cat. No.
<b>QIAamp DNA Blood Mini Kits — for genomic DNA purification from blood and body fluids</b>		
QIAamp DNA Blood Mini Kit (50)	50 QIAamp Spin Columns, QIAGEN Proteinase K, Reagents, Buffers and Collection Tubes (2-ml)	51104
QIAamp DNA Blood Mini Kit (250)	250 QIAamp Spin Columns, QIAGEN Proteinase K, Reagents, Buffers and Collection Tubes (2-ml)	51106
<b>QIAamp 96 DNA Blood Kits* — for high-throughput genomic DNA purification from blood and body fluids</b>		
QIAamp 96 DNA Blood Kit (4)	4 QIAamp 96 Plates, QIAGEN Proteinase K, Reagents, Buffers, Lysis Plates, and Collection Vessels	51161
QIAamp 96 DNA Blood Kit (24)	24 QIAamp 96 Plates, QIAGEN Proteinase K, Reagents, Buffers, Lysis Plates, and Collection Vessels	51163
<b>QIAamp DNA Mini Kits — for genomic DNA purification from tissue, blood, and body fluids</b>		
QIAamp DNA Mini Kit (50)	50 QIAamp Spin Columns, Proteinase K, Reagents, Buffers and Collection Tubes (2-ml)	51304
QIAamp DNA Mini Kit (250)	250 QIAamp Spin Columns, Proteinase K, Reagents, Buffers and Collection Tubes (2-ml)	51306
<b>Accessories</b>		
Buffer AW1 (concentrate)	242 ml Wash Buffer 1 Concentrate for 1000 preparations	19081
Buffer AW2 (concentrate)	324 ml Wash Buffer 2 Concentrate for 1000 preparations	19072
Buffer AVL	5 x 31 ml Viral Lysis Buffer and 5 x 310 µg Carrier RNA for 250 preparations	19073
Buffer AL	216 ml for 1000 preparations	19075

\* Requires use of the QIAGEN 96 WellPlate Centrifugation System. Please inquire.

## Ordering Information

Product	Contents	Cat. No.
Buffer ATL	200 ml Tissue Lysis Buffer for 1000 preparations	19076
Buffer AE	240 ml Elution Buffer for 1000 preparations	19077
Collection Tubes (2-ml)	1000 Collection Tubes (2-ml)	19201
QIAGEN Proteinase K	125 mg (40–45 mAU/mg lyophilized)	19155
QIAGEN Proteinase	4 x 125 mg (40–45 mAU/mg lyophilized)	19157
QIAGEN Proteinase K (2)	2 ml (>600 mAU/ml, solution)	19131
QIAGEN Proteinase K (10)	10 ml (>600 mAU/ml, solution)	19133
QIAvac 6S	Vacuum manifold for processing 1–6 QIAGEN 8-well strips; includes QIAvac 6S Top Plate with flip-up lid, Base, Waste Tray, Blanks, Strip Holder	19503
QIAvac Luer Adapter Set*	For processing 1–24 QIAGEN spin columns on QIAvac 6S; 6 adapters with 4 luer connectors each, 24 plugs with 100 disposable connectors for use with QIAamp spin columns on QIAvac Luer Adapters	19541
VacConnectors (100)	100 disposable connectors for use with QIAamp spin columns on QIAvac Luer Adapters	19405
VacConnectors (500)	500 disposable connectors for use with QIAamp spin columns on QIAvac Luer Adapters	19407
Vacuum Regulator	For use with QIAvac manifolds	19530

\* Compatible only with QIAvac Top Plates containing flip-up lid.

## QIAGEN Companies

Please see the inside front cover for contact information for your local QIAGEN office.

## QIAGEN Distributors

**Argentina**  
**Tecnobab S.A.**  
 Tel: [011] 4555 0010  
 Fax: [011] 4553 3331  
 E-mail: info@tecnobab.com.ar  
 Web site: www.tecnobab.com.ar

**Austria**  
**VWR International GmbH**  
 Tel: [01] 376 00 0  
 Fax: [01] 376 00 600  
 E-mail: info@a1.vwr.com  
 Web site: www.vwr.com

**Belgium/Luxembourg**  
**Westburg b.v.**  
 Tel: 0800-19815  
 Fax: [31] 33-4951222  
 E-mail: info@westburg.nl  
 Web site: www.westburg.nl

**Brazil**  
**Unificiencia do Brasil**  
 Tel: 011 3622 2320  
 Fax: 011 3622 2323  
 E-mail: info@unificiencia.com  
 Web site: www.unificiencia.com

**China**  
**Gene Company Limited**  
 Tel: [852]2896-6283  
 Fax: [852]2515-9371  
 E-mail:

**Hong Kong:** info@genehk.com  
**Beijing:** gene@public2.bio.net.cn  
**Shanghai:** gene@public.sio.net.cn  
**Chengdu:** gene@public.cd.sc.cn  
**Guangzhou:**  
 gzy@bio-public.guangzhou.gd.cn

**Croatia**  
**INEL Medicinska Tehnika d.o.o.**  
 Tel: [01] 2984898  
 Fax: [01] 65203966  
 E-mail: inel-medicinska-tehnika@zg.tel.hr

**Cyprus**  
**Scientonics Ltd**  
 Tel: 02-357 22 765416  
 Fax: 02-357 22 764614  
 E-mail: a.scorpeta@bioionics.com.cy

**Czech Republic**  
**BIO-CONSULT spol. s r.o.**  
 Tel/Fax: [420] 2 417 29 792  
 E-mail: bio-cons@fin.cz  
 Web site: www.bio-consull.cz

**Denmark**  
**VWR International A/S**  
 Tel: 43 86 87 88  
 Fax: 43 86 87 90  
 E-mail: info@dk.vwr.com  
 Web site: www.vwr.com

**Egypt**  
**Chinlab**  
 Tel: 52 57 212  
 Fax: 52 57 210  
 E-mail: Chinlab@link.net

**Finland**  
**VWR International Oy**  
 Tel: [09] 804 551  
 Fax: [09] 8045 3200  
 E-mail: info@vwr.com  
 Web site: www.vwr.com

**Geneva**  
**Bioanalytica S.A.**  
 Tel: [210] 640 03 18  
 Fax: [210] 646 27 48  
 E-mail: bioanaly@chd.ch

**Hungary**  
**Kosztel-Hed Co. Ltd.**  
 Tel: [01] 385 3887  
 Fax: [01] 381 0695  
 E-mail: info@kosztel.hu  
 Web site: www.kosztel.hu

**India**  
**Genasis**  
 Tel: [011] 2542 1714  
 or [011] 2515 9346  
 Fax: [011] 2546 7637  
 E-mail: genasis@data.vsnl.net.in

**Ireland**  
**Westburg (Ireland) Ltd.**  
 Tel: 08-6650813/4  
 or 1-800 20 20 20 (toll free)  
 Fax: 08-6650934  
 E-mail: info@westburg.co.il  
 Web site: www.westburg.co.il

**Korea**  
**IKS Laboratories, Inc.**  
 Tel: [02] 924 86 97  
 Fax: [02] 924 86 96  
 E-mail: webmaster@i-lab.co.kr  
 Web site: www.i-lab.co.kr

**Malaysia**  
**RESEARCH BIOLABS SDN. BHD.**  
 Tel: [603] 8070 3101  
 Fax: [603] 8070 5101  
 E-mail: biolab@rm.net.my  
 Web site: www.researchbiolabs.com

**Mexico**  
**Quimica Valaner S.A. de C.V.**  
 Tel: [55] 55 25 57 25  
 Fax: [55] 55 25 56 25  
 E-mail: qvalaner@infosal.net.mx

**The Netherlands**  
**Westburg b.v.**  
 Tel: [033] 4950094  
 Fax: [033] 4951222  
 E-mail: info@westburg.nl  
 Web site: www.westburg.nl

**New Zealand**  
**Biobab Ltd**  
 Tel: [09] 980 6700  
 or [0800] 933 966  
 Fax: [09] 980 6788  
 E-mail: biobab@biobabgroup.com  
 Web site: www.biobabgroup.com/nz

**Norway**  
**VWR International AS**  
 Tel: 22 90 00 00  
 Fax: 22 90 00 40  
 E-mail: info@nb.vwr.com  
 Web site: www.vwr.com

**Poland**  
**Syngene Biotech Sp.z o.o.**  
 Tel: [071] 351 41 06  
 or [061] 70 60 07  
 Fax: [071] 351 04 88  
 E-mail: info@syngene.pl  
 Web site: www.syngene.pl

**Portugal**  
**IZASA PORTUGAL, LDA**  
 Tel: [21] 424 7312  
 Fax: [21] 417 2674

**Singapore**  
**Research Biobabs Pte Ltd**  
 Tel: 62731066  
 Fax: 62734914  
 E-mail: biolab@singnet.com.sg

**Slovak Republic**  
**BIO-CONSULT Slovakia spol. s r.o.**  
 Tel/Fax: [02] 5022 1336  
 E-mail: bio-cons@pasa.sk  
 Web site: www.bio-consull.cz

**Slovenia**  
**MEDLINE d.o.o.**  
 Tel: [01] 830-80-40  
 Fax: [01] 830-80-70  
 or [01] 830-80-63  
 E-mail: medline@siol.net

**South Africa**  
**Southern Cross Biotechnology (Pty) Ltd**  
 Tel: [021] 671 5166  
 Fax: [021] 671 7734  
 E-mail: info@scb.co.za

**Spain**  
**IZASA, S.A.**  
 Tel: [93] 902 20 30 90  
 Fax: [93] 902 22 33 66  
 E-mail: suminita@izasa.es

**Sweden**  
**VWR International AB**  
 Tel: [08] 621 34 00  
 Fax: [08] 760 45 20  
 E-mail: info@se.vwr.com  
 Web site: www.vwr.com

**Taiwan**  
**QIAGEN Bioscience Corporation**  
 Tel: [02] 2880 9913  
 Fax: [02] 2880 9916  
 E-mail: tai@qia.com

**Thailand**  
**Theresa Trading Co. Ltd.**  
 Tel: [02] 412-5672  
 Fax: [02] 412-3244  
 E-mail: theratrading@um.ac.th

**Turkey**  
**Medix Medical Ürünler ve Sağlık Hizmetleri A.Ş.**  
 Tel: [216] 302 15 80  
 Fax: [216] 302 15 88  
 E-mail: medix@medix-ol.com

**All other countries**  
**QIAGEN GmbH, Germany**

17.9 PCR Etiquette

17.9.1 Area Definitions and Traffic Flow

AREA NUMBER	FUNCTION	CONTAMINATING MOLECULES	CONTAMINATION ISSUE	LABORATORY NUMBER(S)
Molecular Laboratory Area #1	MAKE ALL MASTER MIXES	NONE	GUARD AGAINST CONTAMINATION WITH NA AND AMPLICONS FROM AREAS #2 AND #3	338
Molecular Laboratory Area #2	SPECIMEN PREPARATION AND NA EXTRACTION	NUCLEIC ACID	GUARD AGAINST CONTAMINATION WITH NA AND AMPLICONS FROM AREA #3	339 347 BSL
Molecular Laboratory Area #3	AMPLIFICATION AND DETECTION OF AMPLICONS (amplified DNA)	AMPLICONS	DANGEROUS SOURCE OF AMPLICON CONTAMINATION FOR AREAS #1 AND #2	348

17.9.1.1 (Area #1) Of all the lab areas in the complex, it is most imperative that you guard against contamination in this area. This is where PCR master mix buffers are kept. They must be free of contaminating nucleic acid and amplicons (previously amplified DNA) or all your results will be false-positives. By analogy, this area is at the top of a waterfall. Your aim is to keep contaminating nucleic acid and amplicons from traveling upstream into this area. If you “roam” around this room without gloves and lab coat you are a likely source of contamination. If you bring items previously kept in areas 2 or 3, they are likely sources of contamination.

17.9.1.2 (Area #2) This is the second cleanest area. Specimens are processed and nucleic acid is extracted in this area.. The area is regularly bleached to minimize contamination with nucleic acid from previous tests and/or with amplicons that made their way up the waterfall to area 2 from area 3. However, you have to assume that if you touch something in this area you may be picking up contaminating nucleic acid or amplicons. If you travel upstream into area #1 you are a potential source of contamination.

17.9.1.3 (Area #3) **This is the most “dirty” area of the complex in that you must assume that the room is contaminated with amplicons. The room is bleached regularly to minimize the presence of amplicons on surfaces but if you rest your hand on a bench you may pick up amplicons. If you travel upstream to areas 1 and 2 you are likely a source of contamination.**

## 17.9.2 Rules of Conduct

### 17.9.2.1 Area #1

- 17.9.2.1.1 Upon entering room put on gloves and lab coat (one that ties in the back) when working in hood.
- 17.9.2.1.2 Upon entering room put on gloves if you are only checking temperatures, stocks of reagents etc.
- 17.9.2.1.3 Never bring any item into the room if that item has been stored or placed in areas #2 and #3.
- 17.9.2.1.4 Never bring any nucleic acid or amplified material into the room.
- 17.9.2.1.5 Bleach PCR work stations before preparing master mixes.
- 17.9.2.1.6 Keep PCR work stations clean. Turn on UV light in the work station when not in use.
- 17.9.2.1.7 Once a week, clean common areas with bleach to include bench areas, freezer/refrigerator handles, entrance door, and other exposed surfaces.
- 17.9.2.1.8 Conduct a wipe test to check for the presence of contaminating amplicons/nucleic acid (see Appendix section 17.10 below for instructions on how to conduct this test).

### 17.9.2.2 Area #2

- 17.9.2.2.1 Wear lab coat and gloves stored in area #2 or they can be the same as worn in area #1. However, never re-enter area #1 with lab coats/gloves that were used in area #2.
- 17.9.2.2.2 Clean all work station surfaces with bleach before you begin processing specimens
- 17.9.2.2.3 Work on absorbent white paper when practical.
- 17.9.2.2.4 Confine waste material from processing and nucleic acid extraction to the biohazard bins.
- 17.9.2.2.5 Bleach and clean work station surfaces when finished.
- 17.9.2.2.6 On a regular basis, bleach common areas such as door handles, refrigerator/freezer handles, pipettors and other surfaces that are commonly handled.
- 17.9.2.2.7 Never introduce amplified material into the area.
- 17.9.2.2.8 Conduct a wipe test to check for the presence of contaminating amplicons/nucleic acid (see Appendix section 17.10 below for instructions on how to conduct this test).

17.9.2.3 Area #3

- 17.9.2.3.1 Wear lab coat and gloves. These can be the same as worn in area #2. However, never re-enter areas #1 or #2 with lab coats/gloves used in area #3.
- 17.9.2.3.2 Amplified material must be confined in bags in the biohazard bin. LightCycler capillary tubes are placed in the sharps container.
- 17.9.2.3.3 Never carry amplified material out of the room unless confined as described above.
- 17.9.2.3.4 Never exit the room with contaminated gloves.
- 17.9.2.3.5 Bleach all carrier plates before returning them to area #2.
- 17.9.2.3.6 It is best to prop the doors open during work hours to avoid contamination inherent with touching the door handles. There are no biohazards in area #3 so air exchange is not a safety concern.
- 17.9.2.3.7 Clean all surfaces with bleach before you begin processing specimens.
- 17.9.2.3.8 Work on absorbent white paper when practical.
- 17.9.2.3.9 Bleach and clean the work station area when finished
- 17.9.2.3.10 On a regular basis, bleach common areas such as door handles, refrigerator/freezer handles, pipettors and other surfaces that are commonly handled.
- 17.9.2.3.11 Conduct a wipe test to check for the presence of contaminating amplicons/DNA (see Appendix section 17.9 below for instructions on how to conduct this test).

## 17.10 Molecular Biology Wipe Test

### 17.10.1 Protocol

- 17.10.1.1 A wipe test is conducted when the negative control in an assay demonstrates a positive amplification result. This is indicative of possible contamination of the work environment with either nucleic acid or amplicons (previously amplified material).
- 17.10.1.2 This wipe test will identify if and at what locations nucleic acid and /or amplicons are contaminating surfaces and instrumentation.
- 17.10.1.3 Identify areas to be surveyed and mark them in the appropriate fields on the Wipe Test bench work sheet (17.10.2). Include a positive and negative control for each test.
- 17.10.1.4 Label the appropriate number of eppendorf microfuge tubes corresponding to each area to be surveyed and for the controls.
- 17.10.1.5 Transfer 500 µl of water into each tube. Use a sterile filter swab to survey each area. Insert the swab into the water in the tube, wipe a section of the area to be tested (DNA or amplicons will be picked up by the wet swab), and return the swab to the tube. Break off the end of the swab stick and seal the tube.
- 17.10.1.6 Repeat the process for each area to be tested. Make sure that you change gloves between swab sample collection.
- 17.10.1.7 For the negative control, insert a clean swab into the labeled tube, break off the stick, and seal the tube.
- 17.10.1.8 For the positive control, insert the swab into appropriate positive control as described in the SOP above, transfer swab to the labeled tube, break off the stick and seal the tube.
- 17.10.1.9 Vortex all tubes for 1 minute and centrifuge at 13,000 rpm's for 2 minutes at room temperature.
- 17.10.1.10 Follow directions in the manual for the preparation of the amplification master mix, operation of instrumentation, and analysis and interpretation of the data.
- 17.10.1.11 Identify areas that result in a positive amplification reaction. Note these areas on the bench work sheet. These are the areas that contain contaminating DNA or amplicons. Remember when analyzing the data the positive control must demonstrate a positive amplification result and the negative control must demonstrate a negative amplification result.
- 17.10.1.12 Areas testing positive and that are contaminated with DNA or amplicons must be cleaned with 10% bleach followed by extensive water rinsing.
- 17.10.1.13 The cleaned areas must be re-tested for contamination following steps 17.10.1.3-17.10.1.12 above.
- 17.10.1.14 The wipe test is concluded when all areas surveyed demonstrate a negative amplification result.

17.10.2

### Wipe Test Bench Work Sheet

LightCycler File		LightCycler Used	Self Check
Performed by:		A    B    C	Pass <input type="checkbox"/> Fail <input type="checkbox"/>
Date Tested		ccc.File date	
Agent Tested			

Sample	Area Tested	Result	Remarks
1			
2			
3			
4			
5			
6			
7			
8			
9			
10			
11			
12			

	LOT#	EXPIRATION
DNA/RNA Master Enzyme Kit		
UNG		
PRIMERS		
PROBES		
Water-Negative Control		
Positive Control		



17.11

LightCycler Maintenance Documentation Table  
YEAR: \_\_\_\_\_

LightCycler A

	JAN	FEB	MAR	APR	MAY	JUNE	JULY	AUG	SEP	OCT	NOV	DEC
Clean Housing												
Clean Inside												
Change ccc file	x	x	ccc	x	x	x	x	x	ccc	x	x	x
Review												

LightCycler B

	JAN	FEB	MAR	APR	MAY	JUNE	JULY	AUG	SEP	OCT	NOV	DEC
Clean Housing												
Clean Inside												
Change ccc file	x	x	ccc	x	x	x	x	x	ccc	x	x	x
Review												

LightCycler C

	JAN	FEB	MAR	APR	MAY	JUNE	JULY	AUG	SEP	OCT	NOV	DEC
Clean Housing												
Clean Inside												
Change ccc file	x	x	ccc	x	x	x	x	x	ccc	x	x	x
Review												

LightCycler D

	JAN	FEB	MAR	APR	MAY	JUNE	JULY	AUG	SEP	OCT	NOV	DEC
Clean Housing												
Clean Inside												
Change ccc file	x	x	ccc	x	x	x	x	x	ccc	x	x	x
Review												

Frequency: Clean housing and the inside of the instrument monthly; change ccc file every six months.  
See: Roche Molecular Biochemicals LightCycler Operator's Manual, version 3.5. Roche Diagnostics GmbH. Roche Applied Science. 68298 Mannheim, Germany. October, 2000.

17.12

MagNA Pure Maintenance Log-Year \_\_\_\_\_

	JAN		FEB		MAR		APR		MAY		JUNE	
	UV	Bleach	UV	Bleach	UV	Bleach	UV	Bleach	UV	Bleach	UV	Bleach
1												
2												
3												
4												
5												
6												
7												
8												
9												
10												
11												
12												
13												
14												
15												
16												
17												
18												
19												
20												
21												
22												
23												
24												
25												
26												
27												
28												
29												
30												
31												

	JAN	FEB	MAR	APR	MAY	JUNE
Reviewed By						

Procedure Performed Daily. See: *Roche Applied Science MagNA Pure LC Operators Manual, version 3.0*. Roche Diagnostics GmbH, Roche Applied Science. 68298 Mannheim, Germany. Version 3.0, 2004.

17.12 (continued)

MagNA Pure Maintenance Log-Year \_\_\_\_\_

	JULY		AUG		SEPT		OCT		NOV		DEC	
	UV	Bleach	UV	Bleach	UV	Bleach	UV	Bleach	UV	Bleach	UV	Bleach
1												
2												
3												
4												
5												
6												
7												
8												
9												
10												
11												
12												
13												
14												
15												
16												
17												
18												
19												
20												
21												
22												
23												
24												
25												
26												
27												
28												
28												
30												
31												

	JULY	AUGUST	SEPT	OCT	NOV	DEC
Reviewed By						

Procedure Performed Daily.: See: Roche Applied Science MagNA Pure LC Operators Manual, version 3.0. Roche Diagnostics GmbH, Roche Applied Science. 68298 Mannheim, Germany. Version 3.0, 2004.

17.13

MagNA Pure Monthly O-Ring and Magnet Maintenance Documentation Table  
Year: \_\_\_\_\_

MONTH	LUBRICATE O RINGS	CHANGE O RINGS	LEAK TEST	CLEAN MAGNET
JANUARY				
FEBRUARY				
MARCH				
APRIL				
MAY				
JUNE				
JULY				
AUGUST				
SEPTEMBER				
OCTOBER				
NOVEMBER				
DECEMBER				
Reviewed by:				

See: *Roche Applied Science MagNA Pure LC Operators Manual, version 3.0*. Roche Diagnostics GmbH, Roche Applied Science. 68298 Mannheim, Germany. Version 3.0, 2004 for details.

17.14

ABI 7000 Maintenance Log

**ABI PRISM 7000 MONTHLY MAINTENANCE**

MONTH: \_\_\_\_\_ YEAR: \_\_\_\_\_

**WEEKLY-7000A (#27000177)**

	Date/Initials	Date/Initials	Date/Initials	Date/Initials	Date/Initials
Check for Well Contamination	Clean ____ Dirty ____	Clean ____ Dirty ____	Clean ____ Dirty ____	Clean ____ Dirty ____	Clean ____ Dirty ____
Clean Wells (if Dirty)					
System Hardware: Record "All Pass" or specific test that fails	All pass __	All pass __	All pass __	All pass __	All pass __

**WEEKLY-7000 B (#270001763)**

	Date/Initials	Date/Initials	Date/Initials	Date/Initials	Date/Initials
Clean Wells	Clean ____ Dirty ____	Clean ____ Dirty ____	Clean ____ Dirty ____	Clean ____ Dirty ____	Clean ____ Dirty ____
Check for Well Contamination					
System Hardware: Record "All Pass" or specific test that fails	All pass __	All pass __	All pass __	All pass __	All pass __

**WEEKLY-7000C (#270003556)**

	Date/Initials	Date/Initials	Date/Initials	Date/Initials	Date/Initials
Check for Well Contamination	Clean ____ Dirty ____	Clean ____ Dirty ____	Clean ____ Dirty ____	Clean ____ Dirty ____	Clean ____ Dirty ____
Clean Wells (if Dirty)					
System Hardware: Record "All Pass" or specific test that fails	All pass __	All pass __	All pass __	All pass __	All pass __

**MONTHLY**

	7000A		7000 B		7000 C	
	Date	Initial	Date	Initial	Date	Initial
Background Check						

**MONTHLY**

	Date	Initial
Change Compression Pad		

**6 MONTH INTERVAL**

	7000 A		7000 B		7000 C	
	Date	Initial	Date	Initial	Date	Initial
Change Lamp						
ROI Calibration						
Background Calibration						
FAM Spectral Calibration						

See: ABI Prism 7000 Sequence Detection System User Guide. Chapter 10: System Maintenance. Applied Biosystems, 2003.

17.5

**Illinois Department of Public Health  
Division of Laboratories  
2121 W. Taylor St  
Chicago, IL 60612**

**Detection of Norovirus by  
Reverse Transcriptase-Polymerase Chain Reaction (RT-PCR)**

Spec. #	Name	Not Detected	Subtype G1	Subtype G2	Inc.*/Unsat**	Comments

\* Inconclusive, specimen inhibitory to RT-PCR  
\*\* Specimen unsatisfactory

This test has not been cleared or approved by the U.S. Food and Drug Administration.

Test was developed and performance properties determined by the Illinois Department of Public Health Laboratory.

Results are to be used for epidemiological purposes only.

Comments:

T: 815-432-2483  
F: 815-432-2198

Illinois Dept. of Public Health  
Molecular Diagnostics Laboratory  
F: (312) 793-0077  
T: (312)793-0750

18. APPROVAL

*John Dawicki*  
Author

9-11-06  
Date

*J. Paul*  
Unit Supervisor(s)

09-20-06  
Date

*George Dikes*  
Laboratory Manager(s) (as appropriate)

9-20-06  
Date

*Maria Kaminski*  
QA Administrator, Division of Laboratories

*NS 12-4-06*

12-5-06  
Date

*David F. Carpenter*  
CLIA Director

12-11-06  
Date

*Bernard T. Johnson*  
Chief, Division of Laboratories

12-11-06  
Date

# **CHEERS QAPP 3**

## **Appendix 18: UIH Laboratory Description**



**UNIVERSITY OF ILLINOIS MEDICAL CENTER  
CLINICAL MICROBIOLOGY LABORATORY**

The Clinical Microbiology Laboratory is a full-service laboratory offering diagnostic bacteriology, mycology, parasitology, virology, and mycobacteriology. The laboratory receives specimens from in-patients at the University of Illinois Hospital and the University's out-patient clinics, as well as from several outreach sites throughout Illinois and the United States. The Microbiology Laboratory is composed of several sections including Aerobic and Anaerobic Bacteriology, Mycology, Parasitology, Mycobacteriology.

The Aerobic Bacteriology Section isolates and identifies clinically significant microorganisms from clinical specimens and performs antimicrobial susceptibility testing on these bacterial pathogens. These functions are performed with the Vitek-2 automated instrument. Additional reference identification and susceptibility testing methods for other, more fastidious bacterial agents are also available. Blood cultures are performed using the cultures using the BactiAlert system, which provides continuous monitoring of blood cultures for the entire 7-day incubation period. The Aerobic Bacteriology Laboratory performs amplified probe tests for detection of *Neisseria gonorrhoeae* and *Chlamydia trachomatis* in urogenital specimens and also has the capability to perform "real-time" PCR on nares swab specimens and other specimen types for rapid detection/identification of methicillin-resistant strains of *Staphylococcus aureus* (MRSA). *This lab section also performs isolation and characterization of clinically significant anaerobic bacteria.* For these purposes, the laboratory is equipped with a glove box, a gas-liquid chromatograph, and other methods to provide accurate identification of anaerobes.

The Mycology Section of the Laboratory performs identification and anti-fungal susceptibility testing on clinically significant yeast isolates and provides identification of pathogenic moulds recovered from clinical specimens, including dermatophytes, moulds causing wound and systemic infections, and systemic mycotic agents such as Histoplasma capsulatum and Blastomyces dermatitidis.

The Parasitology Section provides services for the diagnosis of various parasitic infections and has a great deal of expertise in providing diagnostic parasitology services to several other local hospitals and clinics. Specimens submitted for parasitology include stool specimens for the detection of pathogenic amoebae, and flagellates, and for detection/identification of the ova belonging to various nematode (roundworms), cestode (tapeworms), and trematode (flukes) species. Blood specimens are also submitted for the diagnosis and species identification of malarial parasites.

The Virology/STD Section provides laboratory services to aid in the diagnosis of viral infections. Culture methods are available for several viral agents, and enzyme immunoassay tests are used for detection of several non-cultivable viral agents such as rotavirus. The Virology Section also performs "real-time" molecular detection assays for influenza A and B viruses, and, in cooperation with Molecular Pathology, offers multiplex molecular detection of several other respiratory viruses. This laboratory section also performs HIV-1 antibody enzyme immunoassays, syphilis serology, and cultures for Trichomonas vaginalis.

The Mycobacteriology Section receives specimens for the isolation and identification of acid-fast organisms including *Mycobacterium tuberculosis*, *Mycobacterium avium* complex, and other important mycobacterial pathogens. The laboratory utilizes state-of-the-art methods to detect growth and to confirm the identities of mycobacterial isolates, including the use of chemiluminescent ribosomal RNA probes for species identification. This laboratory section also performs the new FDA-approved Quantiferon TB-Golod blood test for diagnosis of active and latent tuberculosis.

The staff of the Clinical Microbiology Laboratory includes over 22 FTE's. Technical staff participate in teaching Medical Students, Pathology Residents, and Infectious Diseases Fellows. Continuing education is eagerly encouraged and promoted through weekly/monthly teleconferences, seminars, and ongoing lectures. Staff are also encouraged to avail themselves of the many other educational opportunities that exist on the University campus for further education and academic advancement.

The Clinical Microbiology Laboratory is certified by the College of American Pathologists (CAP). The Laboratory subscribes to the CAP Proficiency Testing Program and currently receives the following Proficiency Surveys from CAP (dates in parentheses indicate the lab receipt date of surveys from CAP for the year 2007):

<b>Proficiency Test Area</b>	<b>Surveys Received</b>	<b>Receipt Dates (if known)</b>
Clinical Microscopy	Survey CMM-A	03/19/07
	Survey CMM-B	08/06/07
Blood Parasite Identification	Survey BP-A	01/29/07
	Survey BP-B	05/21/07
	Survey BP-C	09/24/07
Bacteriology	Survey D-A	
	Survey D-B	
	Survey D-C	
Gram Stains	Survey D5-A	02/26/07
	Survey D5-B	07/09/07
	Survey D5-C	10/22/07
Mycobacteriology	Survey E-A	
	Survey E-B	
Mycology	Survey F-A	
	Survey F-B	
	Survey F-C	
Syphilis Serology	Survey G-A	
	Survey G-B	
	Survey G-C	
Chlamydia IF Antigen Detection	Survey HC1-A	
	Survey HC1-B	
	Survey HC1-C	
Chlamydia trachomatis/Neisseria gonorrhoeae by Nucleic Acid Amplification	Survey HC6-A	
	Survey HC6-B	
	Survey HC-6-C	
<u>Helicobacter pylori</u> Antigen Detection	Survey HPS-A	04/04/07
	Survey HPS-B	09/19/07
Bioterrorism Laboratory Preparedness	Survey LPS-A	
	Survey LPS-B	
Parasitology	Survey P-A	
	Survey P-B	
Rapid Anti-HIV-1 Antibody	Survey RHIVW-A	05/02/07
	Survey RHIVW-B	09/19/07
Infectious Mononucleosis	Survey S-A	03/29/07
	Survey S-B	07/12/07
	Survey S-C	11/15/07
Viral Markers	Survey VM-A	
	Survey VM-B	
	Survey VM-C	
Virology Culture	Survey VR1-A	
	Survey VR1-B	
	Survey VR1-C	
Virology-Antigen by Immunofluorescence	Survey VR2-A	
	Survey VR2-B	
	Survey VR2-C	
Virology-Antigen Detection by eia	Survey VR4-A	
	Survey VR4-B	
	Survey VR4-C	

**Director of Clinical Microbiology:**

William M. Janda, Ph.D., D(ABMM)

Phone: 312-996-5608

**Laboratory Manager:**

Linda Bruno, M.A., MT(ASCP)

Phone: 312-996-3635

**Bacteriology/Blood Culture Section Supervisor:**

Kathy Ristow, M.S., MT(ASCP)SM

Phone: 312-996-3175

**Virology/STD Section Supervisor:**

Jo-Ann Curry, B.A., MT(HEW)

Phone: 312-996-5377

**Mycology Supervisor:**

TBA

**UNIVERSITY OF ILLINOIS MEDICAL CENTER AT CHICAGO**  
**PATHOLOGY LABORATORIES**  
**SUBSPECIALTY PROFICIENCY TESTING OVERVIEW**  
**2ND QTR - 4TH QTR, 2006**

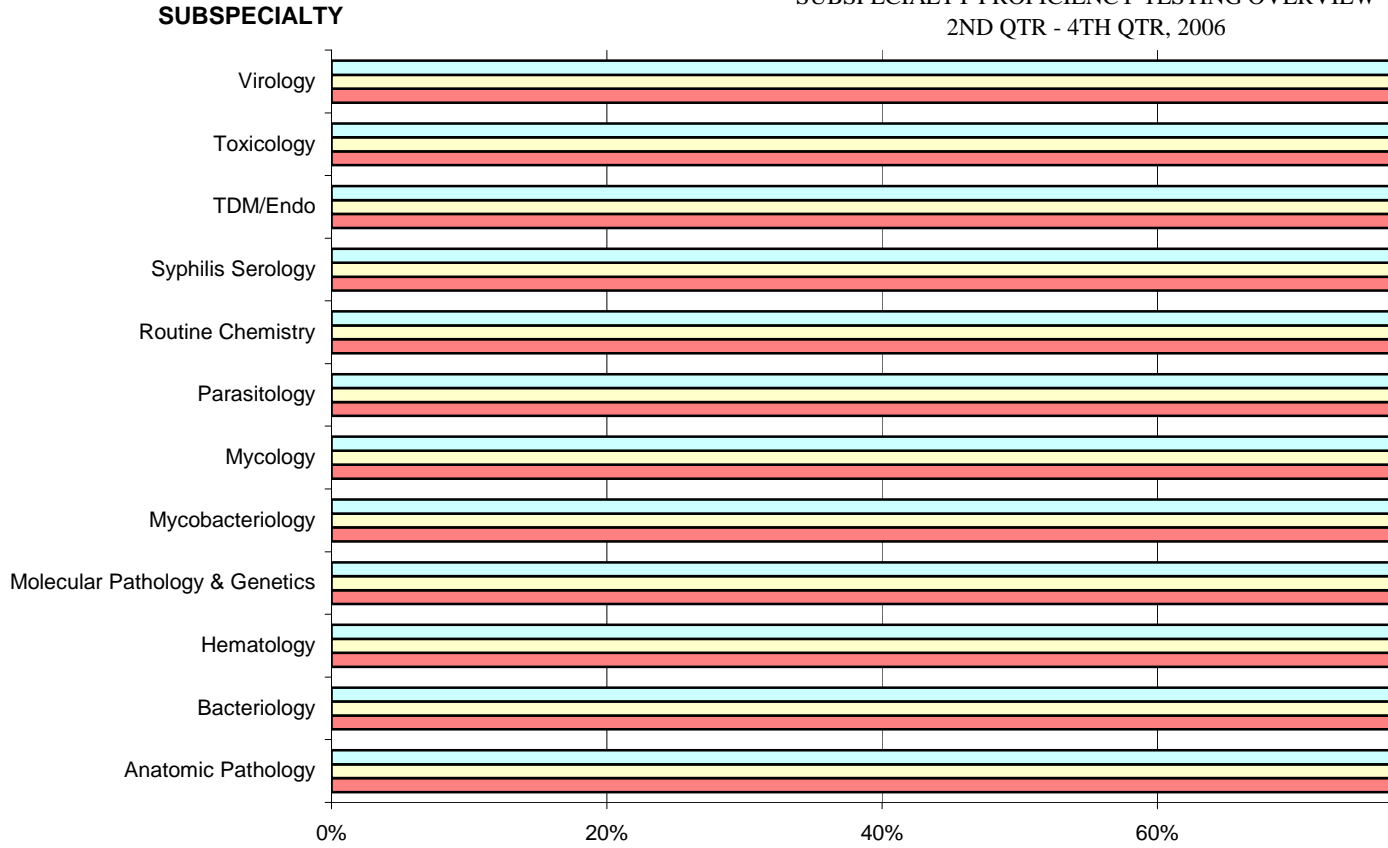

	Anatomic Pathology	Bacteriology	Hematology	Molecular Pathology & Genetics	Mycobacteriology	Mycology	Parasitology	Routine Chemistry	Syphilis Serology
4th QTR 2006	100.0%	100.0%	86.5%	97.3%	100.0%	100.0%	90.9%	99.9%	100.0%
3rd QTR 2006	100.0%	99.0%	86.8%	98.5%	100.0%	100.0%	87.6%	99.5%	100.0%
2nd QTR 2006	100.0%	97.3%	99.3%	97.2%	100.0%	100.0%	90.9%	99.5%	100.0%

**Percent corrected of total graded challenges tested**



*Advancing Excellence*

**Accredited  
Laboratory**



**The College of American Pathologists**

*certifies that the laboratory named below*

***University of Illinois Hospital  
Pathology Laboratories  
Chicago, Illinois  
Robert Folberg, MD***

LAP Number: 1889701

AU-ID: 1184348

*has met all applicable standards for accreditation and  
is hereby fully accredited by the College of American  
Pathologists' Laboratory Accreditation Commission. This  
should occur prior to September 25, 2010, for  
re-accreditation.*

Accreditation does not automatically survive a change of name  
or location and assumes that all interim requirements have been met.

*Robert Wilkins, MD*

Chair, Commission on Laboratory Accreditation

*7*  
Pre

# **CHEERS QAPP 3**

## **Appendix 19: UIH Laboratory CLIA Certification**

**CENTERS FOR MEDICARE & MEDICAID SERVICES  
CLINICAL LABORATORY IMPROVEMENT AMENDMENTS  
CERTIFICATE OF ACCREDITATION**

**LABORATORY NAME AND ADDRESS**

UNIVERSITY OF ILLINOIS PATHOLOGY LAB  
ROOM 215, BLDG 920 (CSB)  
840 SOUTH WOOD STREET, M/C 750  
CHICAGO, IL 60612  
LABORATORY DIRECTOR  
ROBERT FOLBERG MD

**CLIA ID NUMBER**

14D0664392

**EFFECTIVE DATE**

06/14/2007

**EXPIRATION DATE**

06/13/2009

Pursuant to Section 353 of the Public Health Services Act (42 U.S.C. 263a) as revised by the Clinical Laboratory Improvement Amendments (CLIA), the above named laboratory located at the address shown hereon (and other approved locations) may accept human specimens for the purposes of performing laboratory examinations or procedures.

This certificate shall be valid until the expiration date above, but is subject to revocation, suspension, limitation, or other sanctions for violation of the Act or the regulations promulgated thereunder.



*Judith A. Yost*

Judith A. Yost, Director  
Division of Laboratory Services  
Survey and Certification Group  
Center for Medicaid and State Operations

226 certs2\_051907

If you currently hold a Certificate of Compliance or Certificate of Accreditation, below is a list of the laboratory specialties/subspecialties you are certified to perform and their effective date:

<u>LAB CERTIFICATION (CODE)</u>	<u>EFFECTIVE DATE</u>	<u>LAB CERTIFICATION (CODE)</u>	<u>EFFECTIVE DATE</u>
HISTOCOMPATIBILITY (010)	02/11/2003	ABO & RH GROUP (510)	10/13/1995
BACTERIOLOGY (110)	10/13/1995	ANTIBODY TRANSFUSION (520)	10/13/1995
MYCOBACTERIOLOGY (115)	10/13/1995	ANTIBODY NON-TRANSFUSION (530)	10/13/1995
MYCOLOGY (120)	10/13/1995	ANTIBODY IDENTIFICATION (540)	10/13/1995
PARASITOLOGY (130)	10/13/1995	COMPATIBILITY TESTING (550)	10/13/1995
VIROLOGY (140)	10/13/1995	HISTOPATHOLOGY (610)	10/13/1995
SYPHILIS SEROLOGY (210)	01/31/2003	ORAL PATHOLOGY (620)	10/13/1995
GENERAL IMMUNOLOGY (220)	10/13/1995	CYTOLOGY (630)	06/13/2003
ROUTINE CHEMISTRY (310)	10/13/1995	CYTOGENETICS (900)	06/08/2000
URINALYSIS (320)	10/13/1995		
ENDOCRINOLOGY (330)	10/13/1995		
TOXICOLOGY (340)	03/29/2003		
HEMATOLOGY (400)	10/13/1995		

FOR MORE INFORMATION ABOUT CLIA, VISIT OUR WEBSITE AT [WWW.CMS.HHS.GOV/CLIA](http://WWW.CMS.HHS.GOV/CLIA)  
OR CONTACT YOUR LOCAL STATE AGENCY. PLEASE SEE THE REVERSE FOR  
YOUR STATE AGENCY'S ADDRESS AND PHONE NUMBER.  
PLEASE CONTACT YOUR STATE AGENCY FOR ANY CHANGES TO YOUR CURRENT CERTIFICATE.



# **CHEERS QAPP 3**

## **Appendix 20: IDPH Laboratory CLIA Certification**

**CENTERS FOR MEDICARE & MEDICAID SERVICES  
CLINICAL LABORATORY IMPROVEMENT AMENDMENTS  
CERTIFICATE OF COMPLIANCE**

**LABORATORY NAME AND ADDRESS**  
  
ILLINOIS DEPT OF PUBLIC HEALTH LABS  
2121 W TAYLOR STREET  
CHICAGO, IL 60612

**CLIA ID NUMBER**  
14D0691828

**EFFECTIVE DATE**  
02/09/2007

**LABORATORY DIRECTOR**  
DAVID F CARPENTER PHD

**EXPIRATION DATE**  
02/08/2009

Pursuant to Section 353 of the Public Health Services Act (42 U.S.C. 263a) as revised by the Clinical Laboratory Improvement Amendments (CLIA), the above named laboratory located at the address shown hereon (and other approved locations) may accept human specimens for the purposes of performing laboratory examinations or procedures.

This certificate shall be valid until the expiration date above, but is subject to revocation, suspension, limitation, or other sanctions for violation of the Act or the regulations promulgated thereunder.



*Judith A. Yost*

Judith A. Yost, Director  
Division of Laboratory Services  
Survey and Certification Group  
Center for Medicaid and State Operations

If you currently hold a Certificate of Compliance or Certificate of Accreditation, below is a list of the laboratory specialties/subspecialties you are certified to perform and their effective date:

<u>LAB CERTIFICATION (CODE)</u>	<u>EFFECTIVE DATE</u>	<u>LAB CERTIFICATION (CODE)</u>	<u>EFFECTIVE DATE</u>
BACTERIOLOGY (110)	02/09/1993		
MYCOBACTERIOLOGY (115)	02/09/1993		
MYCOLOGY (120)	02/09/1993		
PARASITOLOGY (130)	02/09/1993		
VIROLOGY (140)	02/09/1995		
SYPHILIS SEROLOGY (210)	02/09/1993		
GENERAL IMMUNOLOGY (220)	02/09/1993		
ROUTINE CHEMISTRY (310)	02/09/1995		
ENDOCRINOLOGY (330)	02/09/1995		
TOXICOLOGY (340)	02/09/1995		

FOR MORE INFORMATION ABOUT CLIA, VISIT OUR WEBSITE AT [WWW.CMS.HHS.GOV/CLIA](http://WWW.CMS.HHS.GOV/CLIA)  
OR CONTACT YOUR LOCAL STATE AGENCY. PLEASE SEE THE REVERSE FOR  
YOUR STATE AGENCY'S ADDRESS AND PHONE NUMBER.  
PLEASE CONTACT YOUR STATE AGENCY FOR ANY CHANGES TO YOUR CURRENT CERTIFICATE.

# **CHEERS QAPP 3**

## **Appendix 21: IDPH Laboratory Clinical Quality Manual**

## IDENTIFICATION INFORMATION

**Document Title:** **Illinois Department of Public Health, Division of Laboratories (DOL), Clinical Quality Manual, DCA001-06-1105**

**Effective Date:** 12-08-2005

**Organizational Title:** Illinois Department of Public Health, Division of Laboratories

### Addresses:

1155 S. Oakland St., P.O. Box 2797  
Carbondale, IL 62902  
Phone: 618-457-5131

2121 W. Taylor  
Chicago, IL 60612  
Phone: 213-793-4760

825 N. Rutledge  
Springfield, IL 62794  
217-782-6562

### Responsible Officials:

Bernard Johnson, MS, Chief, Division of Laboratories  
Karen Meier, Manager, Carbondale Laboratory  
George Dizikes, Ph.D., Manager, Chicago Laboratory  
David L. Maserang, Ph. D., CLIA Director, Division of Laboratories

**Division of Laboratory Quality Administrator:** Maria Kaminski

**Scope of this Document:** This Quality Manual has been developed to address the data quality needs of the Illinois Department of Public Health, Division of Laboratories, in the clinical area. This Document reflects the overall QA program framework and the management systems to ensure that clinical data generated by the Division of Laboratories is of acceptable quality to meet the needs of users and decision-makers. It also describes the delegation of quality assurance responsibilities within the DOL. This document meets the requirements for a Quality Manual for the following laboratory certification program:

- Medicare, Medicaid and CLIA Programs; *Laboratory Requirements Relating to Quality Systems and Certain Personnel Qualifications*; Final Rule, January 24, 2003

**APPROVALS\*:**

Maria Kaminski  
\_\_\_\_\_  
Author

11/07/2005  
\_\_\_\_\_  
Date

Karen Meier  
\_\_\_\_\_  
Carbondale Laboratory Manager

11/28/2005  
\_\_\_\_\_  
Date

George Dizikes, Ph.D.  
\_\_\_\_\_  
Chicago Laboratory Manager

11/14/2005  
\_\_\_\_\_  
Date

David L Maserang, Ph.D.  
\_\_\_\_\_  
CLIA Laboratory Director

12/01/2005  
\_\_\_\_\_  
Date

Maria Kaminski  
\_\_\_\_\_  
Division QA Administrator

11/30/2005  
\_\_\_\_\_  
Date

Bernard T. Johnson  
\_\_\_\_\_  
Chief, Division of Laboratories

12/08/2005  
\_\_\_\_\_  
Date

\* Original signatures – LIS file.

Table of Contents  
Title

Section Number	Title
1.0	Quality Assurance Policy
1.1	Scope of the DOL Clinical Quality Manual
2.0	Organization and Responsibilities
2.1	Carbondale Laboratory Organization
2.2	Chicago Laboratory Organization
2.3	Springfield Laboratory Organization
2.4	Laboratory Key Personnel
2.5	Training Procedures
3.0	Laboratory Physical Facilities
3.1	Carbondale Laboratory Physical Facility
3.2	Chicago Laboratory Physical Facility
3.3	Springfield Laboratory Physical Facility
3.4	Laboratory Improvement Section
4.0	General Laboratory System
4.1	Ethics
4.2	Confidentiality
4.3	Specimen Identification and Integrity
4.4	Customer Complaints and Communication
4.5	Personnel Competency Assessment
4.6	Evaluation of Proficiency Testing Performance
5.0	Quality Assurance Objectives
5.1	Test Variability/Reproducibility
5.2	Accuracy
5.3	Precision
6.0	Preanalytical System
6.1	Specimen Management Protocol
6.2	Specimen Collection
6.3	Established Procedures
6.4	New Work or Procedures
6.5	Specimen Receipt and Logging
6.6	Test Requisition Form
6.7	Specimen Submission, Handling, and Referral
6.8	Purchase and Handling of Consumables and Services
7.0	Analytical System
7.1	Standard Operation Procedures

## Table of Contents

Section Number	Title
7.2	Test Systems, Equipment, Instruments, Reagents, Materials and Supplies
7.3	Establishment and Verification of Performance Specification
7.4	Maintenance and Function Checks
7.5	Calibration and Calibration Verification
7.6	Control Procedures
7.7	Comparison of Test Results
7.8	Corrective Actions
7.9	Test Records
8.0	Post Analytical System
8.1	Data Review Procedure
8.2	Final Test Reports
8.3	Records
8.4	Corrective Action Report
8.5	Specimen Retention
9.0	Documentation Management
9.1	CLIA Documents
9.2	Routine QA Operating Documents and Analytical Records
9.3	Administrative Records
9.4	Record Storage Procedure
9.5	Data Security
10.0	System Audits
10.1	Scope and Frequency of Audits
10.2	Types of Audits
10.3	Managerial Review Procedure
11.0	Definitions
12.0	References
13.0	Appendices
Appendix 1	Directive
Appendix 2	Administrative Operating Procedures
Appendix 3	Personnel Training Record
Appendix 4	Calibration/Verification of Laboratory Support Equipment
Appendix 5	Comparison of Test Results
Appendix 6	CLIA Personnel File Documentation
Appendix 7	Quarterly Managerial Review Forms
Appendix 8	Semi-Annual Managerial Review Forms
Appendix 9	Quarterly Quality Assurance Report

## **1. QUALITY ASSURANCE POLICY**

The mission of the Illinois Department of Public Health (IDPH) is to promote the health of the people of Illinois through the prevention and control of disease and injury. The IDPH Division of Laboratories participates in the fulfillment of this mission by providing data of exceptional quality. Figure 1-1 shows the placement of the Division of Laboratories in IDPH. The high level of data quality is maintained by an established quality assurance program that provides a mechanism to evaluate and monitor work quality, identify and correct non-conformities, validate accuracy, precision, sensitivity and timeliness of analytical results, and provide personnel training.

Adherence to the quality assurance program requirements is the responsibility of all laboratory personnel. This responsibility is stated in Directive 01-01, *Quality Assurance/Quality Control*, dated October 1, 2002, and signed by the Chief of the Division of Laboratories. In addition, employees participate in the Division's continuous quality improvement efforts. Through the process of continuous quality improvement, the services of the Division are constantly being examined and improved.

### **1.1 SCOPE OF THE DOL CLINICAL QUALITY MANUAL**

This Quality Manual summarizes the policies and administrative procedures associated with the Illinois Department of Public Health, Division of Laboratories Clinical Laboratories and establishes a structured quality system for all phases of the total process; that is, preanalytic, analytic, and postanalytic, as well as general laboratory systems. All policies and procedures have been structured in accordance with the Clinical Laboratory Improvement Act (CLIA). This manual has been prepared in accordance with the documents listed in Section 12. Further details of the Division's administrative procedures are contained in directives listed in Appendix 1 and standard operating procedures listed in Appendix 2.

All laboratory activities performed by the Illinois Department of Public Health, Division of Laboratories, Clinical Laboratories, are performed in accordance with this document. The laboratories provide services and assistance to referring physicians, public health care providers, federal and local law enforcement agencies, other approved providers, and State of Illinois agencies.

The IDPH Clinical Laboratories analyze clinical specimens in the specialties and sub-specialties of Microbiology, Serology, Virology, Molecular Diagnostics, Chemistry, and metabolic/genetic diseases. The laboratories also perform animal rabies testing.

Occasionally, the Division will find it necessary to allow a departure from approved procedures due to unusual circumstances or specimens. The procedure for this departure is contained in SOP DXX011 (draft), *Exceptions Permitting Departures from Documented Policies or Procedures*. The procedure in this SOP provides the only authorized means by which departures from required procedures and policies can occur.



Figure 1-1

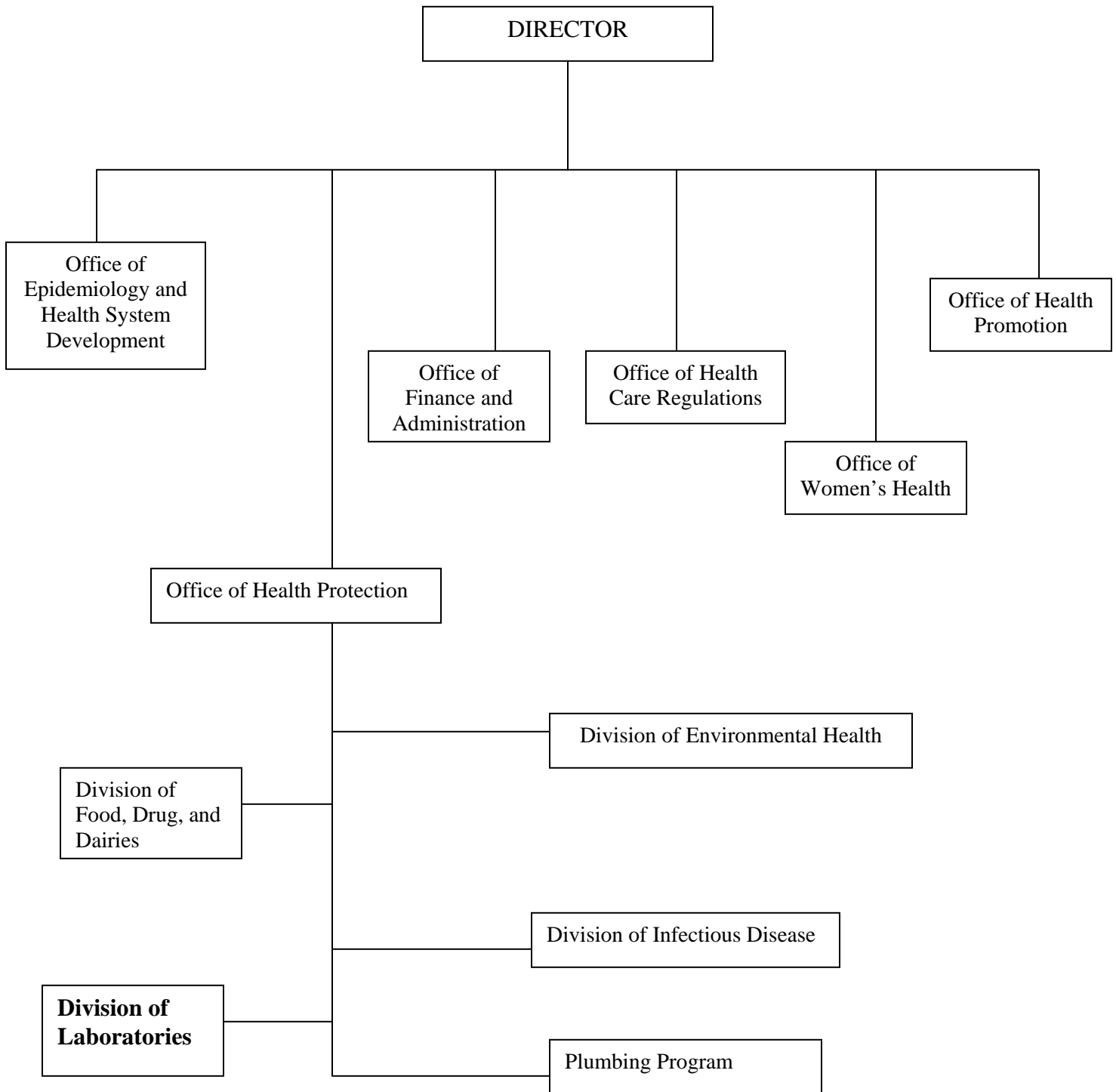

## **2. ORGANIZATION AND RESPONSIBILITIES**

The Division of Laboratories is a division of the Illinois Department of Public Health and is thus legally identifiable as a State of Illinois agency. For the purpose of clinical analyses, the Division of Laboratories is divided into three separate organizational units, all under the supervision of the Chief, Division of Laboratories. They are the Carbondale Laboratory, the Chicago Laboratory, and the Springfield Laboratory. The Division of Laboratories, Laboratory Improvement Section is responsible for the overall management of the laboratory quality system and its implementation. Figure 2-1 is a divisional organizational chart as it relates to clinical testing. The Laboratory Improvement Section maintains a record of employee's name, initials, and signature for all individuals who are responsible for signing or initialing any laboratory record.

### **2.1 CARBONDALE LABORATORY ORGANIZATION**

The Carbondale Laboratory is headed by the Carbondale Laboratory Manager and the Clinical Supervisor. The laboratory is organized and operates in such a way that it meets the requirements of all appropriate standards. The laboratory specifies and documents the responsibility, authority, and interrelationships of all personnel who manage, perform or verify work affecting the quality of testing.

### **2.2 CHICAGO LABORATORY ORGANIZATION**

The Chicago Laboratory is headed by the Chicago Laboratory Manager. The Chicago Laboratory consists of four sections: Microbiology, Virus-Serology, Metabolic/Genetic Diseases and Molecular Diagnostics, all under the supervision of the Laboratory Manager. These sections are headed by the technical supervisors (section chiefs). The laboratory is organized and operates in such a way that it meets the requirements of all appropriate standards. The laboratory specifies and documents the responsibility, authority, and interrelationships of all personnel who manage, perform or verify work affecting the quality of testing.

### **2.3 SPRINGFIELD LABORATORY ORGANIZATION**

The Springfield Laboratory consists of two sections: Diagnostic and Molecular, all under the supervision of the Laboratory Manager. Both sections are headed by a supervisor. The laboratory is organized and operates in such a way that it meets the requirements of all appropriate standards. The laboratory specifies and documents the responsibility, authority, and interrelationships of all personnel who manage, perform or verify work affecting the quality of testing.

### **2.4 LABORATORY KEY PERSONNEL**

#### **2.4.1 MANAGEMENT**

Laboratory management is responsible for defining the minimum level of qualification, experience, and basic laboratory skills necessary for all positions within the laboratory.

Laboratory managerial staff and their specific responsibilities are listed here. Each managerial staff member is provided with the authority and resources needed to discharge his/her duties.

#### **2.4.1.1 CHIEF, DIVISION OF LABORATORIES**

The Chief, Division of Laboratories, is responsible for the coordination of analytical services between the three laboratories. He/she is responsible for ensuring that standardized laboratory systems are used at each laboratory so that the data generated is similar in format, content, and quality; providing budgetary oversight of laboratory operations to verify that required financial controls and accounting procedures are in place; formulating long-term goals in facilities, staffing, equipment, and analytical capabilities. Specific responsibilities include the following:

- Delegating authority and responsibilities to the laboratory managers/directors to implement their duties;
- Being accessible to the laboratory to provide consultation either on site or by phone or pager;
- Developing, establishing and maintaining written laboratory policies.

#### **2.4.1.2 CLIA LABORATORY DIRECTOR**

The laboratory director is responsible for the overall operation and administration of the laboratory, including the employment of personnel who are competent to perform test procedures, record and report test results promptly, accurately and proficiently, and for assuring compliance with the applicable regulations. The laboratory director, if qualified, may perform the duties of the technical supervisor, clinical consultant, general supervisor, and testing personnel, or delegate these responsibilities to personnel meeting the qualifications. If the laboratory director reapporitions performance of his or her responsibilities, he or she remains responsible for ensuring that all duties are properly performed. The laboratory director must be accessible to the laboratory to provide onsite, telephone or electronic consultation as needed. The laboratory director must:

- Ensure that testing systems developed and used for each of the tests performed in the laboratory provide quality laboratory services for all aspect of test performance, which includes the preanalytic, analytic, and postanalytic phases of testing;
- Ensure that the physical plant and environmental conditions of the laboratory are appropriate for the testing performed and provide a safe environment in which employees are protected from physical, chemical, and biological hazards;
- Ensure that test methodologies selected have the capability of providing the quality of results required for patient care;

- Verifies that procedures used are adequate to determine the accuracy, precision, and other pertinent performance characteristics of the method and that laboratory personnel are performing the test methods as required for accurate and reliable results;
- Ensure that the laboratory is enrolled in an HHS-approved proficiency testing program for the testing performed and that the proficiency testing samples are tested as routine specimens; the results are returned within the timeframes established by the proficiency testing program; all proficiency testing reports received are reviewed by appropriate staff to evaluate the laboratory's performance and to identify any problems that require corrective action; and an approved corrective action plan is followed when any proficiency testing result is found to be unacceptable or unsatisfactory as outlined in the proficiency testing SOP, DAA017;
- Ensure that the quality control and quality assessment programs are established and maintained to assure the quality of laboratory services provided and to identify failures in quality as they occur;
- Ensure the establishment and maintenance of acceptable levels of analytical performance for each test system;
- Ensure that all necessary remedial actions are taken and documented whenever significant deviations from the laboratory's established performance characteristics are identified, and that patient test results are reported only when the system is functioning properly;
- Ensure that reports of test results include pertinent information required for interpretation;
- Ensure that consultation is available to the laboratory's clients on matters relating to the quality of the test results reported and their interpretation concerning specific patient conditions;
- Ensure that a general supervisor provides on-site supervision of non-waived test performance by qualified testing personnel;
- Employ a sufficient number of laboratory personnel with the appropriate education and either experience or training to provide appropriate consultation, properly supervise and accurately perform tests and report test results;
- Ensure that prior to testing patients' specimens, all personnel have the appropriate education and experience, receive the appropriate training for the type and complexity of the services offered, and have demonstrated that they can perform all testing operations reliably to provide and report accurate results;
- Ensure that policies and procedures are established for monitoring individuals who conduct preanalytic, analytic, and postanalytic phases of testing to assure that they are

competent and maintain their competency to process specimens, perform test procedures and report test results promptly and proficiently, and whenever necessary, identify needs for remedial training or continuing education to improve skills;

- Ensure that an approved procedure manual is available to all personnel responsible for any aspect of the testing process; and
- Specify, in writing, the responsibilities and duties of each consultant and each supervisor, as well as each person engaged in the performance of the preanalytic, analytic, and postanalytic phases of testing, that identifies which examinations and procedures each individual is authorized to perform, whether supervision is required for specimen processing, test performance or result reporting and whether supervisory or director review is required prior to reporting patient test results.

#### **2.4.1.3 CLINICAL CONSULTANT, DIVISION OF LABORATORIES**

The Clinical Consultant, Division of Laboratories is responsible for providing consultation. Specific responsibilities include the following:

- Be available to clients and to the laboratories via phone or e-mail;
- Provide consultation regarding the appropriateness of the testing ordered and interpretation of test results;
- Assist the laboratory's clients in ensuring that appropriate tests are ordered to meet clinical expectations;
- Ensure that reports of test results include pertinent information required for specific patient test interpretation;
- Ensure that consultation is available and communicated to the laboratory's clients on matters related to the quality of the test results reported and their interpretation concerning specific patient conditions.

#### **2.4.1.4 DIVISION OF LABORATORIES MANAGERS / SECTION CHIEFS – TECHNICAL SUPERVISORS**

The technical supervisor is responsible for the technical and scientific oversight of the laboratory. The technical supervisors must be available to the laboratory to provide on-site, telephone or electronic consultation. The technical supervisor's responsibilities include:

- Approve test methodology that is appropriate for the clinical use of the test results according to the latest version/revision of DAA005, *Standard Operating Procedure for Technical and Standard Operations Implementation and/or Change*;

- Verify the test procedures performed and establishment of the laboratory's test performance characteristics, including the precision and accuracy of each test and test system and document such activity as described in SOP DAA005, *Standard Operating Procedure for Technical and Standard Operations Implementation and/or Change*;
- Ensure that the laboratory is enrolled in an HHS-approved proficiency testing program for the testing performed and that the proficiency testing samples are tested as routine specimens; the results are returned within the timeframes established by the proficiency testing program; all proficiency testing reports received are reviewed by appropriate staff to evaluate the laboratory's performance and to identify any problems that require corrective action; and an approved corrective action plan is followed when any proficiency testing result is found to be unacceptable or unsatisfactory as outlined in the latest version/revision of SOP, DAA017, *Standard Operating Procedure for Handling, Analysis, and Reporting of Proficiency Testing Samples*;
- Establish a quality control program appropriate for the testing performed and the parameters for acceptable levels of analytical performance and ensure that these levels are maintained throughout the entire testing process from the initial receipt of the specimen, through sample analysis and reporting of test results;
- Ensure that all necessary corrective actions are taken and documented whenever significant deviations from the laboratory's established performance characteristics are identified, and that patient test results are reported only when the system is functioning properly as outlined in SOP 015, *Standard Operating Procedure for Quality Improvement Actions*;
- Ensure that patient test results are not reported until all corrective actions have been taken and the test system is functioning properly;
- Evaluate the competency of all testing personnel and assuring that the staff maintain their competency to perform test procedures and report test results properly, accurately, and proficiently. See Appendix 6.
- Conduct quality improvement studies that include the following: identify and monitor important quality indicators; define and select thresholds in data generated; analyze data and recommend corrective action to the Director; and, conduct follow-up assessments.
- Perform Management System Reviews - See Appendices 7 and 8.

The technical supervisor is familiar with the calibration of tests and procedures, the objective of the calibration or test, and the assessment of results. The technical supervisor reports to the Laboratory Manager/Laboratory Director and may act as a deputy in the absence of the Laboratory Manager/Director. The technical supervisor must have a minimum of a bachelor's degree in a natural or physical science course work and a minimum of four years laboratory experience with six months experience in the designated area of responsibility. The technical supervisor inform the Laboratory Improvement Section of changes in technical supervision.

#### **2.4.1.5 DIVISION OF LABORATORIES SUPERVISOR – GENERAL SUPERVISOR**

The general supervisor is responsible for day-to-day supervision or oversight of the laboratory operation and personnel performing testing and reporting test results.

- The general supervisor must be accessible to testing personnel at all times testing is performed to provide on-site, telephone or electronic consultation to resolve technical problems in accordance with policies and procedures established either by the laboratory director or technical supervisor;
- Is responsible for providing day-to-day supervision of non-waived test performance by qualified testing personnel;
- Except as listed below, must be on site to provide direct supervision when non waived testing is performed by qualified personnel;
  - \* Exception: For individuals qualified, who were performing non waived testing on or before January 19, 1993, the requirements provide that all non waived testing performed by the individual in the absence of a general supervisor is reviewed within 24 hours by a qualified general supervisor;
- Is responsible for monitoring test analyses and specimen examinations to ensure that acceptable levels of analytical performance are maintained;
- The director or technical supervisor may delegate to the general supervisor the responsibility for:
  - \* Assuring that all remedial actions are taken whenever test systems deviate from the laboratory's established performance specification following the procedure in the latest version/revision of SOP DAA015, *Standard Operating Procedure for Quality Improvement Action*.

The general supervisor is familiar with the calibration of test methods and procedures, the objective of the calibration or test and the assessment of results. The supervisor reports to the section chief – technical supervisor and may act as a deputy in the absence of the Section Chief. The supervisor must have a minimum of a bachelor's degree in a natural or physical science or medical technology with course work relative to the area of supervision, and one-year experience in the analysis of clinical specimens in the area of supervision.

#### **2.4.2 LABORATORY IMPROVEMENT SECTION**

The Laboratory Improvement Section is responsible for the overall management of the laboratory quality system and its implementation. For the purpose of clinical testing, the section consists of the Laboratory Quality Specialists (LQS) who report directly to the Laboratory Quality Supervisor in the Chicago Laboratory and the Laboratory Quality Specialists (LQS) who

report directly to the Laboratory Quality Administrator in the Springfield Laboratory. The Laboratory Improvement Section in Springfield also works with the Carbondale Laboratory.

#### **2.4.1.2 LABORATORY QUALITY ADMINISTRATOR**

The Laboratory Quality Administrator is responsible for the overall management of the Division of Laboratories' quality operations. The Laboratory Quality Administrator has direct access to technical supervisors, Laboratory Director(s), and the Chief, Division of Laboratories. The Laboratory Quality Administrator also functions as a quality manager as defined in ISO 15189. In addition, the Laboratory Quality Administrator does/has the following:

- Conducts internal audits of the entire technical operation annually, notifies laboratory management of deficiencies in the quality system, and monitors corrective action;
- Has documented training and/or experience in QA procedures and is knowledgeable in the quality systems defined by CLIA;
- Has a general knowledge of the analytical procedures;
- Notifies the regulatory agencies of changes in technical supervision and directorship;
- Prepares and presents administrative laboratory training, such as general safety, ethics, general security, and regulation updates;
- Oversees the Division's quality documentation.

#### **2.4.2.2 LABORATORY QUALITY SUPERVISOR**

The Laboratory Quality Supervisor is responsible for the overall management of the Chicago Laboratory's quality operations and assists the Laboratory Quality Administrator with the resolution of regulatory compliance issues. For CLIA compliance issues, the Laboratory Quality Supervisor reports directly to the Laboratory Quality Administrator and has direct access to the technical supervisors and division management.

The Laboratory Quality Supervisor functions as a quality manager as defined in ISO 15189. The Laboratory Quality Supervisor in the Chicago Laboratory performs those functions listed under the Laboratory Quality Administrator, Section 2.4.1.2.

#### **2.4.2.3 CLINICAL LABORATORY QUALITY SPECIALIST (LQS)**

The Clinical LQS is responsible for assisting the Laboratory Quality Administrator and Laboratory Quality Supervisor in coordinating the quality system, its implementation, and certification programs for clinical laboratories. The clinical LQS reports directly to the Laboratory Quality Administrator or Laboratory Quality Supervisor, has direct access to division management and the technical supervisors, and can discuss with them any questions or concerns about the laboratory quality system.



### **2.4.3 SAFETY COMMITTEE/OFFICER**

The laboratory has a designated safety committee/officer. The safety committee/officer assists laboratory supervisors in the implementation of the safety program. The safety committee/officer provides, and/or makes available, safety training for all employees, reviews the laboratory safety manual and safety standard operating procedures, performs safety inspections of the facility, and reviews maintenance documentation for laboratory safety equipment to determine compliance with safety regulations. Areas of noncompliance are reported to the supervisor, and Director and to the Chief, Division of Laboratories. See the laboratory Safety Manual for further details.

### **2.4.4 DIVISION OF LABORATORIES TESTING PERSONNEL**

Testing personnel are responsible for sample analysis and identification of corrective actions. The testing personnel report directly to the designated general supervisor. All testing personnel are responsible for complying with all quality assurance requirements that pertain to their organizational/technical function. The testing personnel are responsible for specimen processing, test performance and reporting test results. Each individual performs only those tests that are authorized by the laboratory director and require a degree of skill commensurate with the individual's education, training or experience, and technical abilities. Each testing personnel must:

- Follow the laboratory procedures for specimen handling and processing, test analyses, reporting and maintaining records of patient test results;
- Maintain records that demonstrate that proficiency testing samples are tested in the same manner as patient specimens;
- Adhere to the laboratory's quality control policies, document all quality control activities, instrument and procedural calibrations and maintenance performed;
- Follow the laboratory's established policies and procedures whenever test systems are not within the laboratory's established acceptable levels of performance;
- Be capable of identifying problems that may adversely affect test performance or reporting of test results and either must correct the problems or immediately notify the general supervisor, technical supervisor, or director;
- Document all corrective actions taken when test systems deviate from the laboratory's established performance specifications.

### **2.5 TRAINING PROCEDURES**

Laboratory personnel are internally trained in health and safety, security, QA procedures, and the laboratory management system. Laboratory personnel are also required to attend regular health and safety and laboratory QA procedures refresher courses. New testing staff is trained for a sufficient number of days by experienced testing personnel prior to performing any laboratory

work on clinical specimens. The length of training is determined by the technical supervisor. This training will include basic laboratory skills, as appropriate. Content and dates of training that each laboratory staff member receives are documented by the immediate supervisor in the personnel training records. Employee review of the Quality Manual and other administrative procedures are documented through the use of signed read receipts. This read receipt verifies that each employee has read, understood, and is using the latest version of the laboratory's SOPs that relate to his/her job responsibilities.

### **2.5.1 GENERAL TRAINING**

The employee reviews the current versions of the appropriate method SOPs. This review is documented by a signed and dated read receipt. Training is provided and documented in the following areas for specimen preparation if applicable:

- Glassware cleaning;
- Specimen logging;
- Analytical balance;
- Use of pipets and other liquid handling systems;
- Quality Control Procedures;
- Reagent preparation techniques;
- Testing procedures (SOP).

The form for training documentation is contained in Appendix 3. The documentation of training is maintained in the employee CLIA personnel file. When a regulatory agency requires additional training certification such as required by the Select Agent Rule, the detailed process will be outlined in the corresponding procedure. Records must be maintained accordingly.

### **2.5.2 CLINICAL SPECIMEN ANALYSES**

Upon assignment to testing, the testing personnel will be trained and assessed to verify capabilities; the personnel assessment will be conducted upon completion of training (initial), after six months, and yearly, thereafter. Testing personnel are also required to participate in a blind sample testing program at least yearly. See Appendix 6.

Figure 2-1

**FIGURE 2.1 DIVISION OF LABORATORIES, CLINICAL ORGANIZATIONAL CHART**

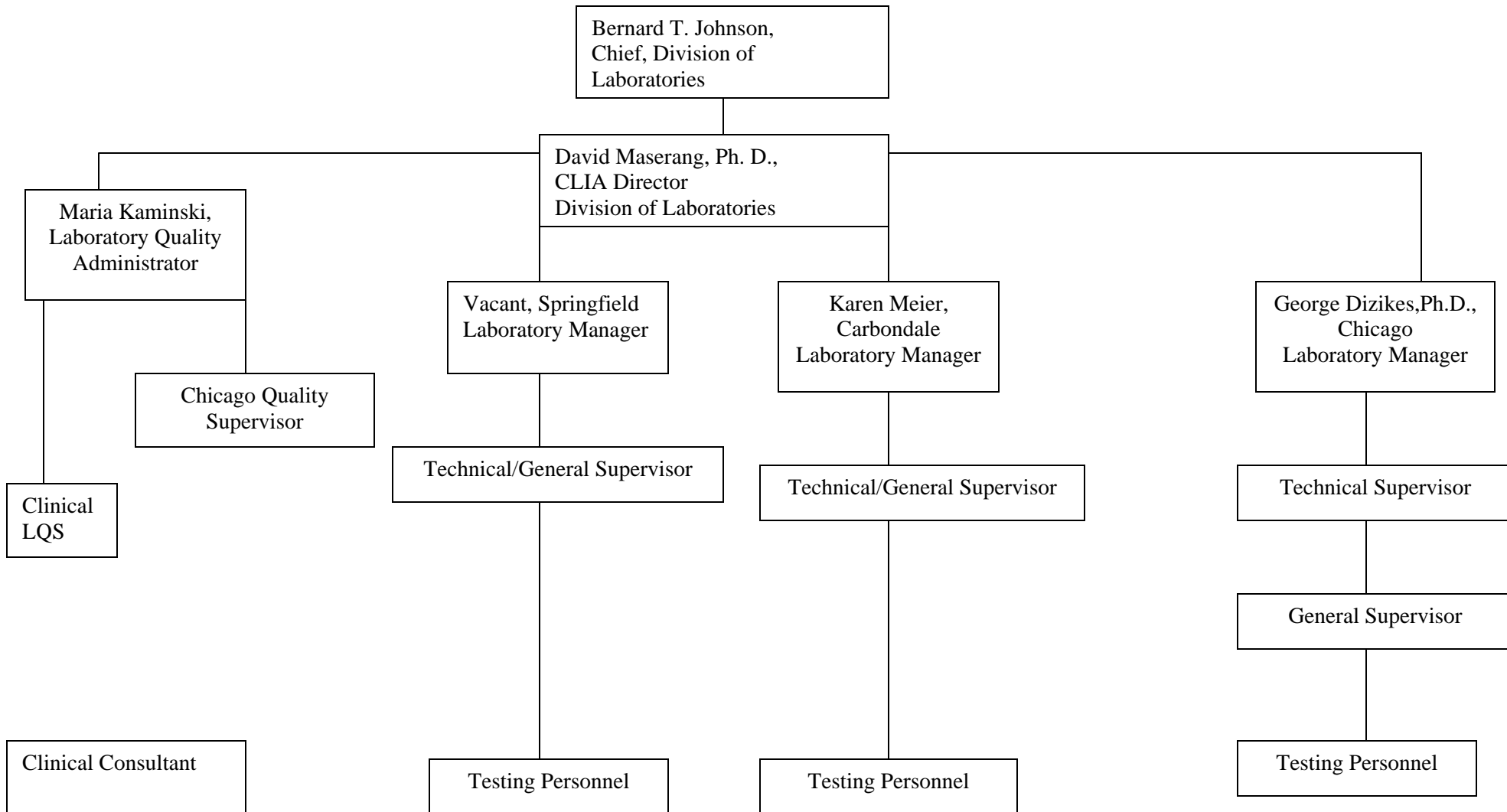

### **3 LABORATORY PHYSICAL FACILITIES**

#### **3.1 CARBONDALE LABORATORY PHYSICAL FACILITY**

##### **3.1.1 ACCOMMODATION AND ENVIRONMENT**

The Carbondale Laboratory is located at only one site as listed in the beginning of this manual. The Carbondale Laboratory is maintained so that the test areas, energy sources, lighting, heating, and ventilation are adequate to facilitate proper performance of testing. The environment of the laboratory is such that it does not invalidate the results or adversely affect the required accuracy of measurements. In instances where monitoring or control of any environmental condition is specified in the test procedure or by regulation, the laboratory will meet and document adherence to the specification. The facility is owned by the Illinois Department of Public Health. Problems with environmental conditions are brought to the attention of the laboratory manager who is then responsible for adjustments and maintenance. A pest and rodent control program is available. The floor plan of the Carbondale Laboratory can be found in the *Carbondale Laboratory Emergency Procedure Manual*.

##### **3.1.2 WORK AREAS**

The laboratory maintains effective separation between neighboring areas when the activities are incompatible. The contamination of specimens, equipment, instruments, reagents, materials and supplies is minimized. Molecular amplification procedures that are not contained in closed systems have a uni-directional workflow including separate areas for specimen preparation, amplification, and product detection, and, as applicable, reagent preparation. Good housekeeping is practiced in the laboratory to ensure that contamination does not adversely affect data quality. Enough work space is available to ensure an unencumbered work area.

#### **3.2 CHICAGO LABORATORY PHYSICAL FACILITY**

##### **3.2.1 ACCOMMODATION AND ENVIRONMENT**

The Chicago Laboratory is located at only one site as listed in the beginning of this manual. The Chicago Laboratory is maintained so that the test areas, energy sources, lighting, heating, and ventilation are adequate to facilitate proper performance of testing. The environment of the laboratory is such that it does not invalidate the results or adversely affect the required accuracy of measurements. In instances where monitoring or control of any environmental condition is specified in the test procedure or by regulation, the laboratory will meet and document adherence to the specification. Environmental conditions are monitored by the building owner, State of Illinois, Central Management Services. Problems with environmental conditions are brought to the attention of the building owner through the building manager who is then responsible for adjustments and maintenance. A pest and rodent control program is available. The floor plan for the Chicago laboratory can be found in the *Chicago Laboratory Emergency Procedure Manual*.

##### **3.2.2 WORK AREAS**

The laboratory maintains effective separation between neighboring areas when the activities are incompatible. The contamination of specimens, equipment, instruments, reagents, materials and supplies is minimized. Molecular amplification procedures that are not contained in closed systems have a uni-directional workflow including separate areas for specimen preparation, amplification, and

product detection, and, as applicable, reagent preparation. Good housekeeping is practiced in the laboratory to ensure that contamination does not adversely affect data quality. Enough work space is available to ensure an unencumbered work area.

### **3.3 SPRINGFIELD LABORATORY PHYSICAL FACILITY**

#### **3.3.1 ACCOMMODATION AND ENVIRONMENT**

The Springfield Laboratory is located at only one site as listed in the beginning of this manual. The Springfield Laboratory is maintained so that the test areas, energy sources, lighting, heating, and ventilation are adequate to facilitate proper performance of testing. The environment of the laboratory is such that it does not invalidate the results or adversely affect the required accuracy of measurements. In instances where monitoring or control of any environmental condition is specified in the test procedure or by regulation, the laboratory will meet and document adherence to the specification. Environmental conditions are monitored by the building owner, Southern Illinois University School of Medicine. Problems with environmental conditions are brought to the attention of the building owner through the building manager who is then responsible for adjustments and maintenance. A pest and rodent control program is available. The floor plan for the Springfield laboratory can be found in the *Springfield Laboratory Emergency Procedure Manual*.

#### **3.3.2 WORK AREAS**

The laboratory maintains effective separation between neighboring areas when the activities are incompatible. The contamination of specimens, equipment, instruments, reagents, materials and supplies is minimized. Molecular amplification procedures that are not contained in closed systems have a uni-directional workflow including separate areas for specimen preparation, amplification, and product detection, and, as applicable, reagent preparation. Good housekeeping is practiced in the laboratory to ensure that contamination does not adversely affect data quality. Enough work space is available to ensure an unencumbered work area.

## **4.0 GENERAL LABORATORY SYSTEM**

### **4.1 ETHICS**

In committing to a standard of excellence, the Illinois Department of Public Health Laboratories expects high ethical standards from all personnel. The management of the IDPH and the Division of Laboratories has stressed the importance of high ethical standards to the employees through a number of documents distributed to all employees. These documents include the following:

Directive 88-03, "Personnel Conduct";  
Directive 97-01, "Professional Conduct";  
SOP DAA003, "Standard Operating Procedure for Data Integrity";

Through the distribution of the above documents, employees agree to abide by these directives and procedures. Any data reporting errors are to be reported to the appropriate laboratory supervisor in a timely manner. The supervisor will then take appropriate action.

### **4.2 CONFIDENTIALITY**

All information about clients/patients, specimens, results, and proprietary rights must be considered confidential. Disclosure of any such information is restricted. Only authorized personnel will be allowed access to such information. All records, including those pertaining to calibration and test equipment, certificates and reports are safely stored, held secure and reported in confidence to the client. The confidentiality of information is communicated to all employees through the distribution of Directive 01-04, "Confidentiality of Test Results". Refer to Section 9.4 concerning storage requirements.

#### **4.2.2 REPORTS BY FAX**

The same limitations apply to Faxed reports as to those by mail. In addition, the following statement must appear on the fax cover page:

#### **"CONFIDENTIAL REPORTS"**

This message is intended for the use of the individual or entity to which it has been addressed and may contain information that is Privileged, Confidential, and exempt from Disclosure under Applicable Law. If the reader of this message is not the intended recipient, or the employee or agent responsible for delivering the message to the intended recipient, you are hereby notified that any dissemination, distribution or copying of this document is strictly prohibited. If you have received this message in error, please notify us by telephone to arrange for returning the faxed document to us.

#### **4.2.3 REPORTS BY PHONE**

When requests are received to report results by telephone, the person reporting the data must document the verbal transmission of results either on the work sheet/test requisition form or in a telephone logbook. The telephone call to report results must either originate from the laboratory to a number verified to belong to the appropriate agency or be from an individual clearly identifiable by voice to the person reporting data. Any verbally transmitted data is to be followed up by sending a written report at the earliest convenience unless a report has been sent or is in transit.

### **4.3 SPECIMEN IDENTIFICATION AND INTEGRITY**

The Division of Laboratories offers to the submitters a manual of services either as hard copy or an electronic file. The manual of services includes instructions for the labeling and handling (storage, shipment) of specimens to maintain the specimen integrity. Upon receipt of the specimen by the Division of Laboratories, the specimen will enter a control system as described in sections 6, 7, and 8.

### **4.4 CUSTOMER COMPLAINTS AND COMMUNICATIONS**

All customer complaints concerning laboratory test data, whether internal or external to the division, are handled according to the procedure contained in SOP DAA016, *Service Improvement Actions*. The completed resolution of complaints form is retained by both, the laboratory section involved and the Laboratory Improvement Section and becomes part of the laboratory records.

### **4.5 PERSONNEL COMPETENCY ASSESSMENT**

Evaluation and documentation of the performance of individuals responsible for testing must be done at six months during the first year the individual tests patient specimens. Thereafter, evaluations must be performed at least annually unless test methodology or instrumentation changes. If changes to methodology or instrumentation do occur, the individual's performance must be reevaluated to include the use of the new test methodology or instrumentation prior to reporting patient test results.

The procedures for evaluation of the competency of the staff are the responsibility of the technical supervisors and must include, but are not limited to the following:

- Direct observation of routine patient test performance, including patient preparation, if applicable, specimen handling, processing and testing;
- Monitoring the recording and reporting of test results;
- Review of intermediate test results or worksheets, quality control records, proficiency testing results, and preventive maintenance records;
- Direct observation of performance of instrument maintenance and function checks;
- Assessment of test performance through testing previously analyzed specimens, internal blind testing samples or external proficiency testing samples;
- Assessment of problem solving skills.

**Each laboratory unit may expand the personnel assessment form to suit individual unit needs.**

Supervisor's remarks must include employee's testing status, remedial training, and follow-up as required. See Appendix 6.

#### **4.6 EVALUATION OF PROFICIENCY TESTING PERFORMANCE**

The laboratory will review and evaluate the results obtained on proficiency testing samples as detailed in the latest version/revision of SOP DAA017, *Standard Operating Procedure for the Handling, Analysis, and Reporting of Proficiency Testing Samples*.



## **5.0 QUALITY ASSURANCE OBJECTIVES**

The overall Quality Assurance objectives for the Illinois Department of Public Health, Division of Laboratories are to develop and implement procedures for laboratory analyses, chain-of-custody (when appropriate), and reporting that will provide results that are of known and acceptable documented quality. Below is a general discussion of data quality indicators (DQIs) used in the laboratory. See specific procedure SOPs for more specific information concerning quality control parameters.

### **5.1 TEST VARIABILITY/REPRODUCIBILITY**

For test procedures that specify parameters for reproducibility, duplicate (or other multiple) analyses are performed and must meet acceptance limits as required by the technical procedure.

### **5.2 ACCURACY**

Accuracy is the degree of agreement between an observed value and an accepted reference value. It is the degree of agreement between a specimen's target (positive or negative) and the actual measured value. Laboratory accuracy is assessed with the use of positive and negative controls at the time of media preparation and during analysis. Negative controls are analyzed to demonstrate that equipment, containers, media and reagents are not contaminated because of improper handling or preparation, inadequate sterilization, or environmental exposure. Positive controls demonstrate that the medium can support the growth of the target organism(s), and the medium produces the specified or expected reaction to target organism(s). Positive controls also are used to determine that the analytical system is functioning correctly for example: antibiotic testing.

### **5.3 PRECISION**

Precision is the degree to which a set of observations or measurements of the same property, obtained under similar conditions, conform to themselves. Precision is usually expressed as standard deviation, variance or range, in either absolute or relative terms.

## **6.0 PREANALYTIC SYSTEM**

### **6.1 SPECIMEN MANAGEMENT PROTOCOL**

With the exception of Metabolic/Genetic Diseases, Clinical testing is not directly available to individuals but must be requested through approved Local Health Department, Regional Offices of the Illinois Department of Public Health, or other public agencies. Requests for special or non-routine analyses must be coordinated through the laboratory in conjunction with a public agency. The Division of Laboratories routinely analyzes blood and body fluids specimens for Microbiology, Serology, Virology, Molecular Diagnostics, Chemistry, and Metabolic/Genetic Diseases. The laboratories also perform animal rabies testing.

### **6.2 SPECIMEN COLLECTION**

Collection of specimens is performed by the appropriate local health department, clinical laboratory, hospital laboratory, IDPH program personnel or other authorized health care provider/individual. The Division of Laboratories personnel do not collect specimens. Testing for public health clinics is coordinated through the Division of Infectious Diseases. The Division of Infectious Diseases will pre-approve facilities for laboratory testing. The request for testing for private laboratories can be made by an individual through the local health department or IDPH regional office. For a detailed list of procedures and specimen collection instructions, refer to the current manual of services.

### **6.3 ESTABLISHED PROCEDURES**

**Microbiology Analyses:** The microbiology specimens are accepted from pre-approved submitters. Microbiology testing includes bacteriology, enterics, parasitology, mycobacteriology, and mycology.

**Serology Analyses:** Serology specimens are accepted only from pre-approved submitters. Serology testing includes testing for Syphilis, HIV, Encephalitic panel, and Hepatitis.

**Virology Analyses:** Virology analyses include viral isolation for enterovirus, respiratory virus and herpes simplex; viral serology for Measles, Rubella, IgM, IgG, and West Nile Virus.

**Molecular Diagnostics:** Molecular diagnostics include testing for Chlamydia and Gonorrhea, viral load for HIV-1, *Mycobacterium tuberculosis*, Pertussis, molecular strain typing, Norwalk-like virus, Leptosporosis, Enterohaemorrhagic *E. coli* (EHEC), and Rabies

**Chemistry:** Chemistry testing includes blood lead.

**Metabolic/Genetic Diseases :** Metabolic/Genetic Diseases include testing for Congenital Hypothyroidism, Biotinidase Deficiency, Congenital Adrenal Hyperplasia, Galactosemia, Amino Acid Disorders, Organic Acid Disorders, Fatty Acid Oxidation Disorders, Sickle Cell and other Hemoglobinopathies.

**Rabies:** Rabies specimens are accepted only from regional, veterinary, animal control, county, or city sanitarian personnel. The sanitarian contacts the epidemiologist of the IDPH Infectious Disease Division to receive assistance in determining the type of symptoms experienced by the victims. After

consulting with the Division of Infectious Disease, the veterinarian or qualified animal control officer should contact the laboratory with specifics of the time and method for shipment.

#### **6.4 NEW WORK OR PROCEDURES**

The laboratories will occasionally receive request for analyses not included in the list of established procedures or beyond the normal workload. Such requests are first discussed by the Chief, Division of Laboratories and program to determine the exact nature of the test, the data quality objectives, the expected sample load, and any regulatory or legal issues. Refer to the following documents:

*Standard Operating Procedure Implementation/Change, Directive 01-02, October 1, 2001;*

*Standard Operating Procedure for Proposals for Technical and Standard Operating Procedure Implementation and/or Change, DAA005.*

New procedures must be reported to the regulatory agency within six months of implementation.

#### **6.5 SPECIMEN RECEIPT AND LOG-IN**

Details of the specimen receipt and acceptance policies can be found in the latest version/revision of the Standard Operating Procedure for specific testing. These standard operating procedures (SOP) contain information on the following sample handling issues:

- Specimen collection kits;
- Litigation specimens;
- Recording of specimen information;
- Specimen preservation, container, storage, and holding times;
- Specimen acceptance policy;
- Specimen log-in sheets or electronic log-in.

#### **6.6 TEST REQUISITION FORM**

Specimens submitted for testing must be accompanied by an Illinois form approved by the Division of Communications. The laboratory must have a written or electronic request for a patient test from an authorized person/facility. The laboratory may accept a verbal request for laboratory tests if it solicits a written electronic authorization within 30 days of the verbal request and maintains the authorization of documentation of its efforts to obtain authorization. See memo from the Chief, Division of Laboratories dated April 29, 2003. The memo is available through the Laboratory Improvement Section.

Test requisition forms must solicit the following information:

- Submitter identification (name and address of facility or submitter code);
- Patient's name or unique patient identifier;
- Sex and age or date of birth of the patient;
- Test(s) to be performed;
- Source of specimen, when appropriate;
- Date, and if appropriate, time of specimen collection;
- Any additional information relevant and necessary for a specific test.

## **6.7 SPECIMEN SUBMISSION, HANDLING AND REFERRAL**

### **6.7.1 WRITTEN INSTRUCTIONS**

The Division of Laboratories will have available to submitters of specimens either written or electronic instructions for:

- Patient preparation;
- Specimen collection;
- Specimen labeling, including patient name or unique identification and, when appropriate, specimen source;
- Specimen storage and preservation;
- Conditions for specimen transportation;
- Specimen processing;
- Specimen acceptability and rejection;
- Specimen referral.

### **6.7.2 DOCUMENTATION**

The laboratory must document the date and time it receives a specimen. This documentation can be performed by manually writing the date and time on the test requisition form, using a mechanical or electronic device to stamp the date and time or by placing the date and time into the database during the scanning of optical character recognition forms.

### **6.7.3 SPECIMEN REFERRAL**

The laboratory must refer a specimen for testing to a CLIA certified laboratory or a laboratory meeting equivalent requirements as determined by the regulatory entity.

## **6.8 PURCHASE AND HANDLING OF CONSUMABLES AND SERVICES**

### **6.8.1 PURCHASE OF REAGENTS AND STANDARDS**

The purchasing of reagents and standards is usually performed by the supervisor or designee of each unit.

### **6.8.2 INSPECTION/ACCEPTANCE REQUIREMENTS FOR SUPPLIES AND CONSUMABLES UPON RECEIPT**

Labels indicating the following information on receipt and testing are to be used for critical supplies and consumables:

- Unique identification name or number (if not clearly shown);
- Date received;
- Date opened;
- Date tested (if applicable);
- Date to be retested (if applicable);
- Expiration date (if not clearly shown)

- Initials

### **6.8.3 OUTSIDE SUPPORT SERVICES AND SUPPLIES**

Only those outside support services and supplies that are of adequate quality to sustain confidence in the quality of testing are to be used. Where no assurance of the quality of equipment and supplies is available, the purchased equipment or supplies are not used until they have been inspected, calibrated or otherwise verified as complying with any standard specifications relevant to the calibration or tests concerned. Work performed by outside support services must be verified to be of adequate quality before any testing dependent on that work is done.

Where applicable, such as in the purchase of specimen collection tubes or specimen collection kits, supplies will be purchased with a certificate or statement indicating suitability for their intended use and those certificates/statement retained. Where no indication of a material's suitability for its intended use is available, a representative batch of that material is tested by using it to prepare test blanks and/or standards and the testing records retained.

## **7.0 ANALYTIC SYSTEM**

### **7.1 STANDARD OPERATING PROCEDURES (SOPs)**

Standard Operating Procedures (SOPS) developed within the Division of Laboratories are reviewed by the technical staff, management, Laboratory Improvement Section, and other designated personnel. SOP development and revisions are initiated by management or Laboratory Improvement staff and approved by the Laboratory Director and the Chief, Division of Laboratories. The DOL SOPs encompass laboratory activities, and quality control practices. SOP documents will be issued and maintained on file in either hard copy or electronically by the pertinent laboratory section, and SOP recipients. The Laboratory Improvement Section maintains on file the historical folders for all SOPs. The procedures for SOPs are detailed in the following documents and SOPs:

*Standard Operating Procedure Implementation/change, Directive 01-02, October 1, 2001;*

*Standard Operation Procedure for Proposals for Technical and Standard Operations Procedure Implementation and/or Change, DAA005;*

*Standard Operating Procedure for the Initiation, Draft, Approval, and Distribution of Standard Operating Procedures, DAA021.*

#### **7.1.1 SOP DISTRIBUTION**

Copies of SOPs will be distributed to all signatories. Other laboratory personnel will receive copies of SOPs based on their job functions. A distribution list will be generated and maintained by the Laboratory Improvement Section for each SOP as determined by the Chief, Division of Laboratories.

### **7.2. TEST SYSTEMS, EQUIPMENT, INSTRUMENTS, REAGENTS, MATERIALS AND SUPPLIES**

Laboratory testing must be performed following the manufacturer's instructions and Standard Operating Procedures in a manner that provides test results within the laboratory's stated performance specification for each test system.

#### **7.2.1 REAGENT, STANDARD AND SPECIMEN STORAGE**

All reagents and commercial kits are marked with initials, date received, date opened, and expiration date. If reagents are prepared, the concentration and content of the solution must also be marked on the container. Standards are stored in each section's designated location for standards and reagents only. Storage of reagents and standards must be consistent with the manufacturer's instructions, if provided. Storage of specimens must be consistent with test manufacturer's instructions, if provided. Specimens must be stored in conditions that support accurate, reliable test operation and results. These conditions must be monitored and documented and, if applicable, include the following:

Water quality;

Temperature;

Humidity;

Light exposure;

Protection of equipment and instruments from fluctuation and interruptions of electrical current.

## **7.2.2 DOCUMENTATION AND LABELS OF STANDARDS AND REAGENTS**

Label and maintain records for all reagents, solution, culture media, control materials, calibration materials, standards, reference cultures, and other supplies including the following:

Manufacturer/vendor;

The manufacturer's Certificate of Analysis or purity (if supplied);

Identity and, when significant, titer, strength or concentration;

The date of receipt;

Initials;

Recommended storage conditions;

Preparation and expiration date;

An expiration date after which the material must not be used;

Other pertinent information required for proper use.

Components of reagent kits of different lot numbers must not be interchanged unless otherwise specified by the manufacturer. Original containers must be labeled with in expiration date unless labeled by the commercial manufacturer. Records are maintained on reagent and standard preparation.

These records contain the following, where applicable:

Traceability to purchased stocks, or reagents;

Reference to the method of preparation;

Final concentration;

Date of preparation;

Expiration date;

Preparer's initials.

This information is recorded in a standards/reagent preparation logbook(s), appropriate quality control form, or electronic record. All containers of prepared reagents and standards bear a unique identifier and expiration date that links the reagent or standard to the documentation requirements recorded in the logbook.

Reagents, solutions, culture media, control materials, calibration materials, and other supplies must not be used after their expiration date has been exceeded, they have deteriorated, or they are found to be of substandard quality.

## **7.3 ESTABLISHMENT AND VERIFICATION OF PERFORMANCE SPECIFICATION**

Any new method that is being considered for routine testing and is FDA-cleared and approved must be subject to a verification of performance specifications study including accuracy, precision, and reportable range. Any FDA-cleared and approved method that has been modified or any test system that is developed by the laboratory must be subject to an establishment of performance specifications study including accuracy, precision, analytical sensitivity, analytical specificity to interfering substances, reportable range, reference intervals, and other performance characteristics. See SOP DAA005, *Standard Operation Procedure for Proposals for Technical and Standard Operations Procedure Implementation and/or Change*.

## **7.4 MAINTENANCE AND FUNCTION CHECKS**

#### **7.4.1 ANALYTICAL SUPPORT EQUIPMENT**

Analytical support equipment includes the following: balances, incubators, laboratory reagent water dispensers, refrigerators, freezers, temperature measuring devices, pH meters, conductivity meters and volumetric dispensing devices. All such support equipment is maintained in proper working order and the records of all activities including service calls are retained. Support equipment is calibrated or verified at least annually, using NIST traceable references, when available, over the entire range of use. The results of the calibration or verification must be within the specifications required of the application for which the equipment is used or the equipment is removed from service until repaired. Refer to the corresponding Preventive Maintenance manual.

Prior to use on each day of use, refrigerators, incubators (day of use), and freezers are checked with NIST traceable references (where possible) in the expected range of use. The acceptability for use or continued use is according to the needs of the analysis or application for which the equipment is being used. Mechanical volumetric dispensing devices (except Class A glassware) are checked for accuracy quarterly. See Appendix 4 for a minimum schedule for the calibration/verification of laboratory support equipment.

#### **7.4.2 LABORATORY INSTRUMENT MAINTENANCE**

All laboratory instruments are maintained in proper working order, and the records of all routine and non-routine maintenance activities including service calls are retained. A record of maintenance is maintained for each instrument to record the date and details of each maintenance activity. Manufacturer's instructions and manuals for the operation of the instruments are stored in an area readily accessible to the instrument operator. Function checks are performed as defined by the manufacturer and with at least the frequency specified by the manufacturer. Function checks must be within the manufacturer's established limits before patient testing is conducted. Function checks must be documented.

#### **7.4.3 LABORATORY INSTRUMENT CALIBRATION**

All laboratory instruments are calibrated in a manner consistent with the appropriate reference method protocols and/or the laboratory's standard operating procedures. In cases where the laboratory needs to use equipment outside its permanent control, the laboratory assures that all requirements for the equipment are met by establishing and maintaining a protocol that ensures performance necessary for accurate and reliable test results and test results reporting. The laboratory must also define a function check protocol that ensures equipment, instrument, and test system performance necessary for accurate and reliable test results and test result reporting. The laboratory must perform and document the function checks, including background or baseline checks specified in the respective procedure manual. Function checks must be within the laboratory's established limits before patient testing is conducted. The results of instrument calibration must meet acceptance criteria. If the calibration acceptance criteria are not met, the instrument is removed from service until repaired or a deviation curve prepared, and all measurements corrected for the deviation. Raw data for all calibrations are retained, as either electronic or hard copy, so that the conditions of the calibration can be reconstructed.

The SOP for each analysis performed in the laboratory describes the calibration procedures, their frequency, acceptance criteria and the conditions that will require re-calibration. When calibration is performed, sufficient raw data is retained to permit reconstruction of the instrument calibration



including the following when appropriate: date, test method, instrument test name, analyst's initials, concentration and response, calibration or response factor, or unique equation or coefficient used to reduce instrument responses to concentration.

## **7.5 CALIBRATION AND CALIBRATION VERIFICATION**

Calibration and calibration verification procedures are required to substantiate the continued accuracy of the test method throughout the laboratory's reportable range for patient test results. Calibration verification is the assaying of calibration materials in the same manner as patient specimens to confirm that calibration has remained stable throughout the laboratory's reportable range for patient test results.

### **7.5.1 CALIBRATION PROCEDURE AND FREQUENCY**

The laboratory will perform and document calibration procedures following the manufacture's test system instructions, using calibration materials provided or specified, and at least the frequency recommended by the manufacturer. All analytical instruments are calibrated with a standard or series of standards, or equivalent materials. These standards are either purchased from various vendors in premixed solutions or prepared directly from neat compounds. The preparation of all standard solutions is documented in standard preparation logbooks. All stock standards are labeled with date received, date opened, date prepared (if prepared in the laboratory), and expiration date. The standards are stored in designated areas and checked for expiration on a regular schedule and prior to use. The laboratory must also perform and document calibration procedures whenever calibration verification fails to meet the laboratory's acceptable limits for calibration verification; at least once every 6 months, and whenever any of the following occur:

- A complete change of reagents for a procedure is introduced, unless the laboratory can demonstrate that changing reagent lot numbers does not affect the range used to report patient test results, and control values are not adversely affected by reagent lot number changes.
- There is a major preventive maintenance or replacement of critical parts that may influence test performance.
- Control materials reflect an unusual trend or shift, or are outside of the laboratory's acceptable limits, and other means of assessing and correcting unacceptable control values fail to identify and correct the problem.
- The laboratory's established schedule for verifying the reportable range for patient test results requires more frequent calibration verification.

Specific calibration requirements for major classes of analytical procedures are described in the following sections.

### **7.5.2 STANDARD RECEIPT AND TRACEABILITY**

A standard (including reference cultures) is a solution or culture containing the organism or test analyte of interest with verifiable accuracy that is used to evaluate that constituent in the specimen or the performance of the test process in the presence of that organism or material. The purity of a material, or an organism/culture must be verified and the accuracy requirements for its measurement available from the source through certification and traceability statements that are kept on file in the

laboratory. All laboratory standards and reference cultures must be traceable to a national standard such as NIST, ATCC, or other documented source. Where traceability to national standards is not possible, the laboratory participates in inter-laboratory testing programs to ensure the quality of the results. Other reagents must have the purity specifications (grades) required by the method. The safety requirements are checked with the material safety data sheets (MSDS) supplied by the manufacturer. Information concerning specific grades of materials used in reagent and standard preparation, appropriate glassware and container for preparation and storage, and labeling and record keeping for all reagents are detailed in the procedure SOPs.

### 7.5.3 VERIFICATION

- Select a minimum of three solutions spanning the reportable range (minimum or 0, mid-point, and maximum), to be run in replicate (recommend two to three times);
- Using appropriate, validated software, plot the assigned value (x axis) versus the mean of the replicates for each level, the observed value (y axis). Draw a line through zero at 45 degree angle where  $y=x$ .
- Compare the observed values with the assigned in terms of the laboratory defined tolerance limits for acceptability. These limits may be specific for each analyte, or may vary with concentration.
- Visually inspect the data for linearity or use linear regression analysis.

**Note:** For calibration verification, CLIA requires at a minimum that observed values fall within the laboratory's acceptable limits, having no regard for linearity.

If all the points are within the laboratory's tolerance limits then calibration verification is acceptable. If calibration verification is unacceptable, then recalibrate and repeat calibration verification. If still unacceptable, then check reagents, troubleshoot the instrument, seek manufacturer technical assistance, etc. until verification is acceptable. Document all corrective actions.

## 7.6 CONTROL PROCEDURES

### 7.6.1 GENERAL REQUIREMENTS

The data acquired from quality control (QC) procedures are used to evaluate the quality of analytical data, to determine the need for corrective action in response to identified deficiencies, and to interpret results after corrective action procedures are implemented. Each SOP includes a QC section that addresses the QC requirements for the procedure. Internal QC requirements are specific for each method but are summarized in this section. The frequency, acceptance limits, and corrective action for QC checks are also described in each SOP. The requirements and procedures for initiating and implementing corrective action are detailed in the following documents:

*Remedial Action, Directive 01-03, October 1, 2001;*  
*Standard Operating Procedure for Corrective Action, DAA015.*

For quality control purposes the laboratory will measure and assure constant and consistent test conditions (both instrumental and environmental) where required by the test method such as

temperature, humidity, light, or specific instrument conditions. Figure 7-1 contains examples of the minimum frequency of quality control samples. Figure 7-2 contains examples of the test quality control requirements. Each procedure SOP details the required, minimum quality control specimens, the minimum frequency, and acceptance criteria.

**FIGURE 7-1 QUALITY CONTROL SAMPLE SUMMARY**

<b>QC Sample</b>	<b>Frequency</b>
Sterility checks	Each new lot number of media, sample bottles, membrane filters, etc
Positive control	Each new lot of media, supplies, each day patient specimens are tested
Negative control	Each new lot of media (where available), media, supplies; each day patient specimens are tested.
Two control materials, positive and negative	Each day patient specimens are tested, extraction phase, molecular amplification
Comparison testing	Each new lot of reagents, new lot of media, new controls
Two control materials of different concentration	Each quantitative procedure
Negative and positive controls	Each qualitative procedure
Negative control and control material with graded or titered reactivity	Each procedure producing graded or titered results
Two control materials including one that is capable of detecting errors in the extraction process	Each test system that has an extraction phase

**FIGURE 7-2 MINIMUM QUALITY CONTROL REQUIREMENTS SUMMARY**

<b>Test</b>	<b>Quality Control Requirement</b>	<b>Frequency</b>
Beta-lactamase	Positive and negative organisms	Each day of use
Gram stain	Positive and negative organisms	Each week of use
Media	Positive and negative organisms	Each batch or each lot
Bact-antiserum	Positive and negative organisms	Upon preparation /open; every six months thereafter
Antimicrobial Susceptibility	Appropriate control organisms	Each day test performed
Acid-fast	Positive and negative organisms	Each day of use
TB susceptibility	Positive and negative organisms	Each week test is performed
Lactphenol Cotton Blue	Positive and negative organisms	Each batch or lot
Fungal susceptibility	Appropriate control organisms	Each day of test
Parasitology	Collection of slides or photographs	Each day of testing
Permanent stain	Sample control material	Each month of use
Virus Isolation	Cell substrate control, bland	Simultaneously with test
Chemistry	Low and high value controls	Each 8 hours
Staining materials	Positive and negative controls	Each day of use

## 7.7 COMPARISON OF TEST RESULTS

Laboratories performing the same test using different methodologies (distinct analytical, chemical, biochemical, molecular etc. techniques or kits) or instruments, must have a system that, twice a year, evaluates and defines the relationship between test results using different methodologies or instruments. Previously tested proficiency test samples or patient specimens may be used. If all samples used to compare test results are within the laboratory's established acceptable range, the test comparison exercise is acceptable. If the test comparison is unacceptable, then calibrate and repeat calibration verification. If still unacceptable, then check reagents, troubleshoot the instrument, etc. until comparison of test results is acceptable. The comparison of test results must be documented using "Comparison of Test Results Report" (Appendix 5).

The laboratory must have a system to identify and assess patient test results that appear inconsistent with the following relevant criteria, when available: patient age, sex, diagnosis or pertinent clinical data, and distribution of patient test results relationship with other parameters.

## 7.8 CORRECTIVE ACTIONS

The laboratory must document all corrective actions taken, including test systems not meeting the established verification specifications as specified in the procedure; equipment and methodology perform outside parameters; patient test values are outside reportable range; or when the laboratory determines that the reference intervals for a test procedure are inappropriate. Corrective action must be taken any time the results of controls or calibration fail to meet the established criteria. Patient test results obtained in the unacceptable test run and since the last acceptable test run must be evaluated. Any time the criteria for proper storage of reagents and specimens is not met, a corrective action must be implemented and documented. See DAA015, *SOP for Quality Improvement Actions*.

## 7.9 TEST RECORDS

The laboratory must maintain an informational record system that includes:

- Positive identification of specimens which initiates an audit trail;
- The test requisition form bearing the date and time the specimen was received. When an optical character form is used, a date/ time record will be recorded upon scanning in an electronic file;
- Worksheets documenting the condition and disposition of specimens that do not meet acceptable criteria;
- Dates of all specimen testing;
- Identity of the personnel who performed the test;
- Records of testing including, if applicable, instrument printouts or electronic equivalents.

## **8.0 POSTANALYTIC SYSTEM**

### **8.1 DATA REVIEW PROCEDURE**

Data resulting from the analysis of specimens are calculated according to protocols described in the laboratory procedure. Computer programs used for data calculation are validated before use. All information used in the calculations (e.g., raw data) is recorded in order to enable reconstruction of the final result at a later date. Information on the preparation of the specimen (e.g., weight or volume of specimen used, dilution factor used) is maintained in order to enable reconstruction of the final result at a later date. All specimen results are reviewed by the unit supervisor or designee before being released.

### **8.2 FINAL TEST REPORTS**

The results of each test, or series of tests, are contained in a final laboratory report and include all the information necessary for the interpretation of the results. Final results may be reported to an interfaced system or manually transcribed or electronically transmitted by the analyst for all specimens. Final reports must be sent promptly only to the authorized person, and if applicable, the individual responsible for using the test results and the laboratory that initially requested the test. Test results are reported according to the specific test SOP. Each final report sent to the customer includes information to interpret the results. The report will include some or all of the following information as required by the accrediting authority:

- Name, and address of the laboratory where the test was performed;
- Unique identification number of the report and all pages numbered. The report identification number and specimen number are equivalent;
- Outbreak number. Outbreak specimens are collected in groups. The group of specimens is reported on one form that is identified with the outbreak number, date and time of collection, and specimen numbers;
- Name and address of test requesting facility or submitter code number;
- Test report date;
- Test performed;
- Specimen source, when appropriate;
- Test results and, if applicable, the units of measurement or interpretation, or both;
- Any information regarding the condition and disposition of specimens that do not meet the laboratory's criteria for acceptability.

After issuance of the report, the report must remain unchanged. Any material amendments to a report after issue are to be made in the form of a further document with the statement "Corrected Report, serial number" or "Amended report, serial number". Amendments will meet all relevant requirements as the original report. In the event that anything is discovered after the issuance of a report that casts doubt on the validity of that report, the authorized person ordering the test and, if applicable the individual using the test results is to be notified promptly. Issue a corrected report and maintain duplicates of the original report, as well as the corrected report.

The laboratory must have available pertinent "reference intervals" or "normal" values. Upon request, the laboratory will make available a list of methods employed and the performance specifications established or verified. Pertinent updates on testing information must be provided to clients whenever changes occur that affect the test results or interpretation of test results.

When the laboratory cannot report test results within its established time frame, the laboratory must determine, based on the urgency of the patient test requested, the need to notify the appropriate individual of the delay.

When the laboratory refers patient specimens for testing, the laboratory must not revise results or information related to the test interpretation; the referring laboratory may send test results directly to the authorized person who initiated the test request. In that case, the laboratory must maintain an exact duplicate of each testing laboratory's report. The laboratory initiating the test request must be notified by the referring laboratory of the name and address of each laboratory where the test was performed.

When test results are submitted to clients by telephone, telex, fax, or other electronic or electromagnetic means, all requirements stated in this section and those in the Section 4.2, "Confidentiality", must be followed.

### **8.3 RECORDS**

Accurate records provide the direct evidence, support, and documentation for the necessary technical interpretations, judgments, and discussions concerning laboratory results. These records, particularly those that are anticipated to be used as evidentiary data, provide the historical evidence needed for later reviews and analyses. Records should be legible, identifiable, and retrievable, and protected against damage, deterioration, or loss. All records referenced in this section are retained for a total of six years; Metabolic/Genetic Diseases will keep records for 21 years. All records will be made available to the accrediting authority upon request. All records are maintained on site and thus immediately available for a period of 2 years.

Electronic or hard copy data is stored securely in each of the laboratories or in the off-site storage/archive facility. Original laboratory logbooks, analyst logbooks, and laboratory worksheets are changed at the beginning of the year or as determined by the technical supervisor, replaced with new ones, and the old logbook stored. Logbooks are also replaced if they show signs of deterioration or as determined by the technical supervisor.

### **8.4 CORRECTIVE ACTION REPORTS**

The process of corrective action is detailed in each method SOP and in SOP DAA015, *Standard Operating Quality Improvement Actions*. Corrective action reports and all pertinent information are retained by the Laboratory Improvement Section.

### **8.5 SPECIMEN RETENTION**

Most specimens and specimen products are discarded shortly after the analysis has been completed and the sample results are reported. The specimens and specimen products are disposed of by the laboratory in accordance with federal and state laws and regulations. Figure 8-1 summarizes the minimum specimen retention schedule. All documents pertaining to specimen storage and tracking are retained, including shipping receipts, transmittal forms, and internal routing and assignment records.

If the specimen is part of litigation, disposal of the physical specimen occurs only with the concurrence of the affected legal authority, specimen data user and/or submitter of the specimen. All conditions of

disposal and all correspondence between all parties concerning the final disposition of the physical specimen are recorded and retained.

Records indicate the date of disposal, nature of disposal (such as specimen depleted, specimen disposed in hazardous waste facility, or specimen returned to submitter), and the name of the individual who performed the task.

Figure 8-1

IDPH Specimen Retention Schedule

TEST	NEGATIVES	POSITIVES	UNSATS
Ch/GC probe	7 days	10 days (frozen)	10 days
GC culture	3 days	3 days	3 days
Throat culture	1 day	5 days	1 day
Syphilis	10 days	3 months (frozen)	10 days
CDC requests	Indefinite (frozen)	Indefinite (frozen)	Indefinite (frozen)
HIV	10 days	5 years (frozen)	10 days
Rabies	1 year (frozen)	1 year (frozen)	1 day
Parasitology	3 days	3 days	1 day
Clinical specimens (enteric) / subcultures	10 days after report	1 year	3 days
Blood lead	5 days	5 days	5 days
Referred cultures (enteric)	1 year	1 year	6 months
Reference culture (misc.)	1 month/final	1 month/final	Till report
MTB RFLP Testing (mail-out)	2 years (frozen)	2 years (frozen)	N/A
Bacteriology culture ID / susceptibility	Subculture 1 week	Subculture 1 week	10 days
TB clinical specimens	5 weeks or until final	Specimen & isolates 2 years (frozen)	10 days
TB referred cultures	N/A	Slants 3 months Isolates 2 years	10 days
Urine culture	24 hours or until final	Specimen & isolate 2 years (frozen)	10 days
Mycology	1 month/final	1 month/final	Until reported
Blood Film	Indefinite	Indefinite	Until reported
HBsAg	10 days	5 years	10 days
Anti-HBs	10 days	5 years	10 days
Anti-HBc	10 days	5 years	10 days
Anti-HBc IgM	10 days	5 years	10 days
Toxoplasmosis	1 month	5 years	10 days
Viral serology	30 days	5 years	10 days
Rubella	Negative & equivocal 3 months (frozen)	10 days	10 days
<b>Metabolic/Genetic Diseases</b>			
	Negative/Unsat	Positives	BDL*s and Unsats
Biotinidase Deficiency	1 wk refrigerated 2 months @ rm. temp.	Frozen indefinitely	4 months refrigerated balance of year @ rm. temp.
Congenital Adrenal Hyperplasia	1 wk refrigerated 2 months @ rm. temp.	Frozen indefinitely	4 months refrigerated balance of year @ rm. temp.
Galactosemia	1 wk refrigerated 2 months @ rm. temp.	Frozen indefinitely	4 months refrigerated balance of year @ rm. temp.
Hypothyroidism	1 wk refrigerated 2 months @ rm. temp.	Frozen indefinitely	4 months refrigerated balance of year @ rm. temp.
Phenylketonuria	1 wk refrigerated 2 months @ rm. temp.	Frozen indefinitely	4 months refrigerated balance of year @ rm. temp.
Sickle Cell Disease and other hemoglobinopathies	1 wk refrigerated 2 months @ rm. temp.	Frozen indefinitely	4 months refrigerated balance of year @ rm. temp.

\*Borderline



## **9. DOCUMENTATION MANAGEMENT AND RECORD RETENTION**

Managing quality documents is the responsibility of the Laboratory Improvement Section with assistance from the laboratory supervisors. The process of document management serves to assure that records are accessible, reviewed and revised on a regular schedule, and protected in storage from damage and deterioration. The IDPH Division of Laboratories follows the provision of the State Records Act (5ILCS 160/1) and the rules established by the State Records Commission to implement this act.

### **9.1 CLIA DOCUMENTS**

Copies of national guidance or requirements document issued by the CLIA's Quality Assurance Division and all HHS documents are maintained by the Laboratory Improvement Section in Springfield. They are distributed by the Laboratory Improvement Section to Division personnel upon request and when documents are updated or changed.

### **9.2 ROUTINE QA OPERATING DOCUMENTS AND ANALYTICAL RECORDS**

All routine QA documents (logbooks, temperature charts, balance checks, specimen receipt logs, etc.) and specimen analysis records are used, properly maintained and stored by the laboratories. All documents and records are maintained on site for a period of three years either as hard copy or electronic equivalents. At the end of on site storage period, documents are inventoried, boxed up and sent to the Secretary of State Records Retention Center and are kept for the appropriate time. See Guideline Record management 91-02 and DAA010, *SOP for Record management*.

See section 8 for detailed information on final reports and laboratory records. Allowing for specific requirements of the analytical process, quality assurance forms established by the Division of Laboratories may be revised by the technical supervisor in order to more accurately reflect the documentation required. The revised forms must contain at a minimum the criteria set by the Division. The revised forms must be reviewed by the Laboratory Improvement staff and be approved by the Laboratory Director and Chief, Division of Laboratories, prior to implementation. Electronic records are considered equivalent to hard copy.

#### **9.2.1 QUALITY MANUAL**

This Quality Manual was developed by the Division of Laboratories and is reviewed by the Division's management and Laboratory Improvement Section. The Division's Quality Manual is a controlled document that is distributed to all employees in the clinical and research sections/units in the DOL. Receipt will be documented with signed read receipts.

#### **9.2.2 DOCUMENT TRACKING**

A master list of controlled documents for the Quality Manual, SOPs, and QA policies will be developed and maintained by the Laboratory Improvement Section. All controlled documents and subsequent approved revisions will be entered into the system by the LQS. The master list of controlled documents includes the title, revision number, effective date, and retirement date of all SOPs. The LQS will monitor the status of all documents to assure timely drafting, review, and approval or revisions.

### **9.2.3 RETIREMENT OF DOCUMENTS**

The LQS will ensure that all DOL quality documents are current. Should one of these documents become outdated, the LQS will initiate a revision of the document. Copies of all quality documents, both current and retired, will be maintained in the Laboratory Improvement Section in a centrally located file area under secure conditions for a minimum of six years.

### **9.2.4 MAINTAINING SENSITIVE DOCUMENT INTEGRITY**

The DOL will take special care to preserve the integrity of all sensitive documents such as audit reports, performance evaluation reports, personnel assessments, and service improvement forms. At the Springfield and Chicago laboratories, these records are in the Laboratory Improvement Office. This office is locked when the Laboratory Quality Specialist/Manager is absent. Access to these records is by permission of the Division Chief, Laboratory Director, and/or the Laboratory Improvement Section only. In Carbondale, these records are located and kept secure in the Laboratory Manager's office.

Analysts have access to those specimen records that are currently being completed. After the records are completed and submitted to the unit supervisor, they are accessible to analysts only with permission of the supervisor. Records that have entered permanent storage are accessible only to the Division Chief, Laboratory Director, Section Chief, Laboratory Improvement Section, or the designated supervisor. If sensitive (confidential, proprietary, evidentiary) documents are used at a workstation, due care and document control processes are used in order to maintain integrity of the data or records. No data or records identified as, or deemed to be confidential, proprietary or evidentiary documents will be distributed outside the Division of Laboratories workstation where they are being used without specific written or verbal permission by the appropriate laboratory technical supervisor. Any issues or questions concerning the internal Division of Laboratories distribution of such documents must be brought promptly to the attention of the applicable section or unit supervisor.

All records will follow the departmental requirements of the Health Insurance Portability and Accountability Act of 1996 (HIPPA).

### **9.2.5 STANDARD OPERATING PROCEDURES**

All methods performed in the Division of Laboratories will have a standard operating procedure that details the procedure and requirements of the method. See SOP DEA021, *The Initiation, Draft, Approval, Distribution, and Revision of Standard Operating Procedures (SOPs)*.

### **9.2.6 EQUIPMENT MAINTENANCE DOCUMENTATION**

Documents detailing the receipt and specification of analytical equipment are retained. A history of the maintenance record of each instrument serves as an indication of the adequacy of maintenance schedules and parts inventory. The performance of all instrument maintenance, either regular or emergency, will be recorded in a logbook, electronic record, or log sheet. The information recorded will include date and initials, the maintenance performed, and the reason for the maintenance.

### **9.2.7 TEST REQUISITIONS AND AUTHORIZATIONS**

Records of test requisitions and test authorizations must be retained including documentation of the laboratory's efforts to obtain authorization to perform the test when a verbal request for test and/or patient demographics has been made. See memorandum dated April 29, 2003, *Operational Change – CLIA Request*. A copy of this memorandum can be obtained from the Laboratory Improvement Section.

### **9.2.8 SPECIMEN ANALYSIS LOGBOOKS/LOGSHEETS**

Specimen analysis logbooks/logsheets/worksheets are used to document the conditions and date of specimen analysis. The information in these logbooks includes specimen numbers and the date of analysis, the method used, and any instrument or specimen information that may be relevant.

### **9.2.9 ORIGINAL DATA**

The raw data and calculated results for all specimens are maintained in laboratory notebooks, logs, bench sheets, files or other sample tracking or data entry forms or electronic equivalents. Instrumental output is stored in a computer file or hard copy report. These records include the following:

- Laboratory specimen ID code;
- Date of analysis;
- All specimen handling and analysis logbook/logsheets or electronic equivalents;
- Instrumentation identification and instrument operating condition/parameters (if appropriate);
- Analysis type and specimen preparation information;
- All manual, automated, or statistical calculations;
- All data system reports including instrument printouts or electronic equivalents;
- Confirmatory analysis data, when required;
- Review history of specimen data; and,
- Analyst's or operator's initials/signature.

### **9.2.10 QC DATA**

The raw data and calculated results for all QC specimens and standards are maintained in the manner described in the preceding paragraph. Documentation allows correlation of sample results with associated QC data. Documentation also includes the source and lot numbers of standards for traceability. QC specimens include, but are not limited to, sterility checks, positive and negative controls and multiple level controls.

### **9.2.11 SYSTEM PERFORMANCE**

Systems performance includes specification that the laboratory has established and verified the test performance specification including verification studies and calibration verification.

### **9.2.12 FINAL REPORT**

A copy of any report issued and any supporting documentation is retained by the laboratory, either in hard copy or retrievable electronic form for a minimum of 6 years (per HIPPA requirements). Reports issued by Metabolic/Genetic Diseases must be retained for 21 years.

### **9.2.13 CORRESPONDENCE**

Correspondence related to specific specimens is retained along with the specimen test requisition form. Correspondence and/or records of conversations concerning the final disposition of rejected specimens are maintained.

## **9.3 ADMINISTRATIVE RECORDS**

Each analyst performing testing must be qualified to perform laboratory testing in accordance with the accrediting agency. The laboratory supervisor assigns the performance of testing to each analyst. The technical supervisor or his/her designee upon staff assignment to that laboratory initiates CLIA personnel files. CLIA personnel files include educational background, initial and continuing demonstrations of capability or personnel assessments, and record of training. CLIA personnel files are maintained in the Laboratory Improvement Section. See Appendix 6.

### **9.3.1 CORRECTIVE ACTION REPORTS**

The process of corrective action is detailed in each method SOP and in SOP DAA015, *Standard Operating Quality Improvement Actions*. Corrective action reports and all pertinent information are retained at a minimum by the Laboratory Improvement Section.

### **9.3.2 AUDIT INFORMATION**

Files of audits (internal and external), as well as the responses and corrective actions associated with them including, but not limited to checklists, correspondence, and follow up are retained at a minimum by the Laboratory Improvement Section. Internal audits will be conducted according to SOP DAA022, *Standard Operating Procedures for Internal Audits*.

### **9.3.3 PERFORMANCE EVALUATION DATA**

These records include but are not limited to the following: all proficiency test raw data, results, corrective action and follow-up (if any). The files are arranged chronologically by survey and retained by the Laboratory Improvement Section and/or the unit supervisor.

### **9.3.4 SUPPLIER AND SUPPLIES RECORDS**

All documentation from suppliers of services is retained. These documents include, but are not limited to the following: records of service contracts, copies of certifications, schedules of services provided. All records associated with goods received are also retained. These records include, but are not limited to instrument manuals and certifications and certificates of analysis for standards and reagents.

## **9.4 RECORD STORAGE PROCEDURE**

All records, including all information necessary for the historical reconstruction of data, must be stored for a minimum of 6 years from the date of completion of analysis; 21 years for Metabolic/Genetic Diseases. For the first two years the records are stored in-house. The data is then stored at the State Records Center in Springfield, Illinois under the authority of the Secretary of State for the remainder of the required time. Stored documentation includes all raw analytical data (computer print-outs, etc), test requisition forms, logbooks, maintenance records, quality control records, controlled documents,

etc. In the event of the closure of the laboratory or when a test is discontinued, the records will be transferred to the State Records Center in Springfield, Illinois. The department programs will be notified in writing of the closure and procedures for obtaining records.

## **9.5 DATA SECURITY**

Analog data from the instruments is converted to digital information by vendor supplied software installed on the laboratory's computers. Consistent, correct analyses of the QC specimens indicate that the data is being received and calculated correctly.

Data from the laboratory's computers is backed up on a regular basis. A copy of this back up is maintained by the Division of Information Technology. Records stored only on electronic media are supported by the hardware and software necessary for their retrieval.

Data is further protected by physical methods. Access to the laboratory is restricted. A series of passwords are also required for entry into any database. Access is restricted to authorized personnel.

Computer and automated equipment are maintained to ensure proper functioning and provided with the environmental and operating condition necessary to maintain the integrity of calibration and test data.

## **10.0 SYSTEMS AUDITS**

### **10.1 SCOPE AND FREQUENCY OF AUDITS**

The Laboratory Improvement Section (LIS) will, on an annual basis, audit all laboratory operations to verify compliance with the requirements of the quality system: preanalytic, analytic, and postanalytic. These audits form the basis of quality improvement action requirements and constitute a permanent record of the conformity of laboratory operations to quality requirements. When audit findings suggest that further investigation may be necessary, the laboratory will investigate and when deemed necessary, take immediate corrective action and immediately notify, in writing, any client whose work may have been affected.

### **10.2 TYPES OF AUDITS**

#### **10.2.1 QUALITY SYSTEM AUDITS**

The quality system audits are based on the quality system elements, activities, and requirements contained in a quality manual. The activities subject to quality system audits are those activities that have a significant effect on the quality of DOL services. The laboratory must monitor and evaluate the overall quality of the preanalytic, analytic, and postanalytic system. Audit procedures and scheduling are detailed in the latest version/revision of SOP DAA022, *Standard Operating Procedure for Internal Audits*.

#### **10.2.2 GENERAL LABORATORY AUDITS**

The general laboratory systems audit must include a review of the effectiveness of improvement actions taken to correct problems, revisions of policies and procedures necessary to prevent recurrence of problems, and discussion of general laboratory systems audit reviews with appropriate staff.

#### **10.2.3 PREANALYTIC SYSTEMS AUDITS**

The preanalytic systems audit must include a review of the effectiveness of improvement actions taken to correct problems, revisions of policies and procedures necessary to prevent recurrence of problems, and discussion of preanalytic systems audit reviews with appropriate staff.

#### **10.2.4 ANALYTIC SYSTEMS AUDITS**

The analytic systems audit must include a review of the effectiveness of improvement actions taken to correct problems, revision of policies and procedures necessary to prevent recurrence of problems, and discussion of analytic systems audit reviews with appropriate staff.

#### **10.2.4 POSTANALYTIC SYSTEMS AUDIT**

The postanalytic systems audit must include a review of the effectiveness of improvement actions taken to correct problems, revision of policies and procedures necessary to prevent recurrence of problems, and discussion of postanalytic systems audit reviews with appropriate staff.

## **10.2.5 PERFORMANCE AUDITS – PROFICIENCY TESTING SPECIMENS**

Performance audits are periodic audits to ensure the quality of results provided to clients by implementing checks to monitor the quality of the laboratory's analytical activities. The audits provide assessment of laboratory performance through the analysis of proficiency testing specimens. The specimens are to be handled, analyzed, and reported according to the procedure in SOP DAA017, *Standard Operation Procedure for Handling, Analysis, and Reporting of Proficiency Testing Samples*. The Division of Laboratories, clinical units, participate in the following programs:

- CAP – College of American Pathology;
- WSLH – Wisconsin State Laboratory of Hygiene;
- CDC – Centers for Disease Control and Prevention;
- AAB – American Association of Bioanalysts.

Other programs may be added as they become available.

## **10.2.6 EXTERNAL AUDITS**

External audits are conducted to verify compliance with rules, regulations, or certification criteria. External audits are conducted with a high degree of formality upon notification and scheduling with the auditing agency. The laboratories are surveyed during the renewal period by the US Department of Health and Human Service, Centers for Medicare and Medicaid Services for Disease Control and Prevention (CMS) for all clinical analyses.

## **10.3 MANAGERIAL REVIEW PROCEDURE**

### **10.3.1 QUARTERLY SUPERVISOR'S REVIEW OF LABORATORY TESTING**

Each laboratory supervisor must quarterly review its policies and procedures for sample and results management, quality control, the relationship of sample information to test results, corrective action, and customer complaints. See Appendix 7 for the form to be used for this review.

### **10.3.2 SEMI-ANNUAL QUALITY ASSURANCE REVIEW AND REPORT**

Each laboratory supervisor must perform a semi-annual review of its QA program including the outcome of recent internal audits and assessment by external organizations. The supervisor must then submit a report to the Laboratory Director and the Laboratory Improvement Section using the forms in Appendix 8. This report summarizes all quality assurance activities for the six-month period.

## **10.4 DOCUMENTATION**

The laboratory must document all preanalytic, analytic, and postanalytic systems audit activities.

## 11.0 DEFINITIONS

**Accuracy:** the degree of agreement between an observed value and an accepted reference value.

**Arithmetic Mean (Mean X):** the number obtained by dividing the sum of a set of quantities by the number of quantities in the set; average. The mean is an arithmetical measure of central tendency. The mean is commonly referred to as the “average”. The mean may be used to indicate the accuracy of a test or analysis.

**Audit:** a formal examination of an organization's or individual's accounts or financial situation; an assessment.

**Calibration:** to determine, by measurement or comparison with a standard, the correct value of each scale reading on a meter, instrument, or other device.

**Calibrator or Standard:** any material that meets established identity, labeling and performance criteria and is used or recommended for use in a calibration process to establish the basis by which specimen values are determined.

**Chain-of-Custody:** a record that documents the possession of the sample from the time of collection to receipt in the laboratory through the analytical testing process, and storage or retention; This record generally includes the number and types of containers, the mode of collection, collector, time of collection, preservation, and requested analysis.

**Coefficient of Variation – CV:** a relative measure of variation, sometimes referred to as the Relative Standard Deviation, RSD; The CV is expressed as percent by the follow formula: (standard deviation divided by the mean) times 100.

**CMS:** US Department of Health and Human Services, Centers for Medicare and Medicaid Services for Disease Control and Prevention.

**Corrective action:** the action taken to eliminate the causes of an existing conformity, defect, or other undesirable situation in order to prevent recurrence.

**Data audit:** a qualitative and quantitative evaluation of the documentation and procedures associated with environmental measurements to verify that the resulting data are of acceptable quality.

**Deficiency:** an unauthorized deviation from acceptable procedure or practices, or a defect in an item or system.

**DOL:** Division of Laboratories

**Holding times (maximum allowable holding time):** the maximum times that samples may be held prior to analysis and still be considered valid or not compromised. Holding time measurement begins with the time of specimen collection.

**ISO:** the International Organization for Standardization; ISO standards are developed by technical committees comprising experts on loan from the industrial, technical, and business sectors that asked for the standards and will subsequently put them to use.



**LQS:** Laboratory Quality Specialist

**May:** denotes permitted action, but not required action.

**Median:** the middle-ranking number in a set of numbers.

**Must:** denotes a requirement that must be met.

**Negative Control – media:** an analysis consisting of the inoculation of media using an organism that should not grow in the media or should not respond in a specific way.

**Negative Control – analytical testing:** an analysis consisting of a sample that does not contain the analyte(s) of interest. A negative control is performed in an analytical test to ensure the test is responding appropriately.

**NIOSH:** National Institute of Occupational Safety and Health

**NIST:** National Institute of Standards and Technology, US Department of Commerce

**PT:** Proficiency Test

**Parallel Testing:** the system used to compare lots and/or shipments of diagnostic reagents/kits or methods. Parallel testing uses identical controls and specimens/samples to determine the consistency of the test system being evaluated (i.e., the only variable is the reagent/kit/test material being evaluated). All reagents are parallel tested prior to use for diagnostic purposes or as screening tests.

**Performance Audit:** the routine comparison of independently obtained qualitative and quantitative measurement system data with routinely obtained data in order to evaluate the proficiency of an analytical system.

**Positive Control – media:** an analysis consisting of the inoculation of media using an organism that should grow in the media or should respond in a specific way.

**Positive Control – analytical testing:** a sample containing the analyte(s) of interest. A positive control is performed in an analytical test to ensure the test is responding appropriately.

**Predictive Value:** the expression of the likelihood that a test result reflects the disease or condition status of an individual; Predictive values may be applied to either positive or negative results. Predictive value is especially useful when screening for diseases or conditions in a population with a low prevalence of the disease or condition.

**Preventive Maintenance – PM:** upkeep, repairs, or maintenance that prevents or impedes breakdown or loss of function in equipment, machinery, or complex systems.

**Precision:** the degree to which a set of observations or measurements of the same property, obtained under similar conditions, conform to themselves. Precision is usually expressed as standard deviation, variance or range, in either absolute or relative terms.

**Preservation:** the act of preserving or controlling the conditions (e.g., environmental, chemical, temperature, etc.) at the time of sample collection (or later) to maintain the chemical and/or biological integrity of the sample.

**Proficiency Testing:** a means of evaluating a laboratory's performance under controlled conditions relative to a given set of criteria through analysis of unknown samples provided by an external source.

**Quality Assurance (QA):** an integrated system of activities involving planning, quality control, quality assessment, reporting and quality improvement to ensure that a product or service meets defined standards of quality with a stated level of confidence.

**Quality Control (QC):** the overall system of technical activities whose purpose is to measure and control the quality of a product or service so that it meets the needs of the users.

**Quality Manager – ISO 15189 –** has delegated responsibility and authority to oversee compliance with the requirements of the quality management system and reports directly to the level of laboratory management at which decisions are made on laboratory policy and procedures.

**Regression:** a statistical measure of the strength of linear association of X and Y; Complete linear association equals unity, while no linear association equals zero.

**Relative Standard Deviation – RSD:** see Coefficient of Variation – CV

**Screening:** the presumptive identification of unrecognized disease or defect by the application of tests, examinations, or other procedures which can be applied rapidly to sort out apparently well persons who probably have a disease from those who probably do not.

**Should:** denotes a guideline or recommendation

**Slope:** the slope is the rate of change of Y for a unit change of X.

**Standard Deviation (SD):** a statistical tool used as a measure of dispersion in a distribution; The SD is the square root of the variance. The standard deviation is a measure of dispersion of results about the mean value of the frequency distribution of the observation. Standard deviation may be used to indicate the precision of a test or analysis.

**Traceability:** the property of a result or a measurement where by it can be related to appropriate standards, generally international or national standards, through an unbroken chain of comparison.

**Validation:** the process of substantiating specified performance criteria.

**Verification:** the confirmation by examination and provision of evidence that specified requirements have been met.

## 12.0 REFERENCES

- 12.1 Health Care Financing Administration 42 CFR Part 493 *Medicare, Medicaid, and CLIA Programs: Laboratory Requirements Relating to Quality Systems and Certain Personnel Qualification*; Final Rule January 24, 2003.
- 12.2 *General Requirements for the Competence of Testing and Calibration Laboratories*, ISP/IEC17025, International Standard, 1999.
- 12.3 *Laboratory Procedure Manuals*, National Committee for Clinical Laboratory Standards, Volume 4, Number 2.
- 12.4 James P. Rux, Ph. D., *Handbook of Quality Assurance for the Analytical Chemistry Laboratory*, Van Nostrand Reinhold Company, N.Y., 1986.
- 12.5 Stanley L. Inhorn, M.D., Editor, *Quality Assurance Practices for Health Laboratories*, American Public Health Association, Washington, D.C., 1978.
- 12.6 John Keenan Taylor, *Quality Assurance of Chemical Measurements*, Lewis Publishers., Chelsea, MI, 1988.
- 12.7 Health Care Financing Administration, 42 CFR Part 405, et. al., *Clinical Laboratory Improvement Amendments of 1988*, Final Rule, February 28, 1992.
- 12.8 J. S. Mausner and A. K. Bahn, *Epidemiology: An Introductory Text*, W. B. Saunders Co., Philadelphia, 1974.
- 12.9 P.E. Leaverton, *A Review of Biostatistics*, Little, Brown & Co., Boston, 1978.
- 12.10 B. L. Therrell, Jr., Editor, *Laboratory Methods for Neonatal Screening*, American Public Health Association, 1993.
- 12.11 ISO15189, *Medical Laboratories – Particular Requirements for Quality and Competence*, ISO 15189:2003(E), ISO 2003

**13.0 APPENDICES:**

13.1 Appendix 1 – Directives

13.2 Appendix 2 – Standard Operating Procedures

13.3 Appendix 3 – Training Documentation

13.4 Appendix 4 - Calibration/Verification of Laboratory Support Equipment

13.5 Appendix 5 – Comparison of Results

13.6 Appendix 6 – CLIA Personnel File Documentation

13.7 Appendix 7 – Quarterly Managerial Review Forms

13.8 Appendix 8 – Semi-Annual Managerial Review Forms

Appendix 1

Directives

Directive Number	Title	Effective Date
01-01	Quality Assurance/Quality Control	October 1, 2001
01-02	Standard Operating Procedure Implementation/Change	October 1, 2001
01-03	Remedial Action	October 1, 2001
88-03	Personal Conduct	October 15, 1988
97-01	Professional Conduct	March 1, 1997
01-04	Confidentiality of Laboratory Test Information	October 1, 2001

Appendix 2

Administrative SOPs

SOP No.	SOP Title	Effective Date
DAA003	SOP for Data Integrity	11/05/2001
DAA005	SOP for Technical and Standard Operation Implementation/Change	11/01/2001
DAA007	Information Technology Procedure Manual	01/03/2005
DAA0010	Standard Operating Procedure for Record Management	02/10/2004
DAA015	SOP for Quality Improvement Actions	12/12/2003
DAA016	SOP for Service Improvement Actions	12/12/2003
DAA017	Standard Operating Procedure for Handling, Analysis, and Reporting of Proficiency Testing Samples	12/12/2003
DAA018	Chemical Hygiene Plan	12/05/2004
DAA021	SOP for Initiation, Draft, Approval, and Distribution of Standard Operating Procedures	12/12/2003
DAA022	Standard Operating Procedure for Internal Audits	01/07/2004
DAA023	SOP for Risk Assessment	3/28/2005
DAA025	SOP for Fiscal Ordering	8/16/2005
DAA028	SOP for Exposure Control to Blood borne Pathogens	1/03/2005
DAS001	SOP for Specimen/Sample Log-In and Receipt	01/01/2004
DCS001	SOP for Preventive Maintenance	09/26/2005

Appendix 3

**Illinois Department of Public Health – Division of Laboratories**

**Personnel Training Record**

Employee Name: \_\_\_\_\_

Supervisor: \_\_\_\_\_

I understand that by initialing, I acknowledge having been instructed and evaluated on each time below. Furthermore, I agree to follow the laboratory’s procedures and policies for the items below.

Employee signature: \_\_\_\_\_

Date: \_\_\_\_\_

<b>Items</b>	<b>Date of Evaluation</b>	<b>Employee Initials</b>	<b>Supervisor Initials</b>
Glassware cleaning			
Specimen log-in			
Analytical balance			
Use of pipets			
Quality Manual			
Emergency Response Plan			
Safety Manual			
Reagent preparation techniques			
Testing procedures (SOP number)			
A.			
B.			
C.			
D.			
E.			
F.			
G.			

Appendix 4

Calibration/Verification of Laboratory Support Equipment

<b>Equipment</b>	<b>Activity</b>	<b>Minimum Frequency</b>	<b>Acceptance</b>
Incubators	Temperature check	Once/day	Varies
Balances	Check with three weights	Monthly	±5%
Refrigerators	Temperature check	Once/day	Varies
Freezer	Temperature check	Once/daily	≤ -15°C
Water bath	Temperature check	Day of use	Varies
Pipets, Pipettors	Volume check	Quarterly	±5%
Temperature monitoring devices	Verification at temperature of use against a NIST thermometer	Yearly	±1°C
pH meter	Calibration	Day of use	Slope 95-102% or ±0.1 of standard pH



Appendix 5

**Illinois Department of Public Health – Division of Laboratories  
Comparison of Test Results Report**

<b>Specimen</b>	<b>Method/Instrument</b>	<b>Result</b>	<b>Acceptable</b>	<b>Initials/Date</b>

Summary: \_\_\_\_\_  
\_\_\_\_\_  
\_\_\_\_\_

Corrective Action: \_\_\_\_\_  
\_\_\_\_\_  
\_\_\_\_\_  
\_\_\_\_\_

Follow-up action to be taken to document that the problem has been solved: \_\_\_\_\_  
\_\_\_\_\_  
\_\_\_\_\_  
\_\_\_\_\_

Prepared by: \_\_\_\_\_  
General/Tech Supervisor: \_\_\_\_\_  
Reviewed by QA Staff: \_\_\_\_\_  
Approved by Laboratory Director: \_\_\_\_\_

Date: \_\_\_\_\_  
Date: \_\_\_\_\_  
Date: \_\_\_\_\_  
Date: \_\_\_\_\_

Appendix 6

**Illinois Department of Public Health – Division of Laboratories  
CLIA Personnel File  
Checklist**

Employee Name: \_\_\_\_\_

Position: \_\_\_\_\_

Date Hired \_\_\_\_\_

	Certificate, license, registry number
	Foreign education equivalency
	High school diploma, degrees, certificates
	Job responsibilities (copy of job description)
	Personnel assessment
	In-service training
	Safety orientation
	Hepatitis B
	Tuberculosis test
	Rabies vaccination

---

Appendix 6 – continued

**Illinois Department of Public Health – Division of Laboratories  
 CLIA Personnel File  
 Laboratory Qualification Appraisal**

<b>Employee Name:</b>	<b>Section assigned:</b>			<b>Hours:</b>
High School Career School	Position <input type="checkbox"/> DIR <input type="checkbox"/> CC <input type="checkbox"/> TC <input type="checkbox"/> TS <input type="checkbox"/> GS <input type="checkbox"/> TP			
Name of College, University, or Professional School Attach any copies of license, transcript evaluation, certification or diplomas	Dates	Major	Degree/Cert.	
<b>Experience: Facility's name</b>	<b>Dates</b>		<b>Position</b>	
<b>Test: Extension of test procedures</b>	<b>Eval Date/ Emp. Initials</b>		<b>Supervisor Init.</b>	
<b>Signature: General/Technical/Supervisor:</b>			<b>Date:</b>	
<b>Director's Signature:</b>			<b>Date:</b>	

Appendix 6 – continued

**Illinois Department of Public Health – Division of Laboratories  
CLIA Personnel File  
Personnel Assessment**

Assessment	Date _____		
<input type="checkbox"/> Semiannual	<input type="checkbox"/> Annual	<input type="checkbox"/> Other	
Employee:	Employee SSN		
Job title	Test		
Performance	<input type="checkbox"/> Sat.	<input type="checkbox"/> Un-sat.	Comment
Direct observation	<input type="checkbox"/> Sat.	<input type="checkbox"/> Un-sat.	Comment
Monitoring, reporting & recording of results	<input type="checkbox"/> Sat.	<input type="checkbox"/> Un-sat.	Comment
Monitoring, reporting & recording of results	<input type="checkbox"/> Sat.	<input type="checkbox"/> Un-sat.	Comment
Review of worksheets PM, QC, PT	<input type="checkbox"/> Sat.	<input type="checkbox"/> Un-sat.	Comment
Direct observation of PM activities	<input type="checkbox"/> Sat.	<input type="checkbox"/> Un-sat.	Comment
Blind test samples	<input type="checkbox"/> Sat.	<input type="checkbox"/> Un-sat.	Comment
Problem solving skills			
General supervisor's remarks			
General supervisor's signature:		Date	
Technical supervisor's remarks (if applicable):			
Technical supervisor's signature:		Date:	

Appendix 7

**Illinois Department of Public Health – Division of Laboratories  
Supervisor’s Review of Laboratory Testing**

Month(s) of \_\_\_\_\_ Date of Review: \_\_\_\_\_ Reviewed by: \_\_\_\_\_

The laboratory must perform a quarterly review of its policies and procedures for patient test management, quality control, proficiency testing, relationship of patient information to test results, communications and complaint investigations. To comply with this requirement, review a representative number of specimens for compliance in the indicated headings. Indicate Sat, if satisfactory, Unsat, if unsatisfactory. Use the comment/corrective action space to document unsatisfactory findings and corresponding corrective action.

Test	Specimens reviewed	Requisitions	Reports	Worksheets	QC	PM	Calibration	Storage	Corrective action	PT	%TAT	Communications

Requisitions: Review specimen processing for accuracy: Specimen identification, test ordered, correct specimen type, appropriate handling, appropriate storage.  
Reports: Assure that requisition information has been accurately transferred to test report; test ordered was performed and reported to authorized person.  
Worksheets: Has all required information including lot #, results from worksheets, instrument printout or electronic transmission been accurately reported.  
QC: Control samples are tested in the same manner as patients, meet established criteria, corrective action is followed when controls are out of limits.  
PM: Records of all instruments requiring preventive maintenance, including corrective action and proper labeling, assure PM schedule is observed.  
Calibration: Records of all instruments requiring calibration to assure that calibration and/or verification is performed at least every 6 months, review for compliance.  
Storage: Specimens, records, and reagents are stored according to schedule or corresponding expiration date.  
Corrective Action: Evaluate corrective actions for effectiveness and follow up.  
PT: PT samples are treated as patients, if unsat participation, review patients’ specimens, review corrective action and follow-up.  
% TAT: Indicate the % of specimens that meet the established TAT for the review period.  
Communications: Review documents that resolve communication problems and complaints, effectiveness of solutions.

Comments: Findings/ Corrective Action:  
 \_\_\_\_\_  
 \_\_\_\_\_  
 Follow-up:  
 \_\_\_\_\_

Appendix 8

Quality Assurance Semi-Annual Report

Lab. Section/Unit:	Date:
PT results/Deviations:	
PT results/Deviations:	
QC Reports:	
Personnel Assessment reports:	
Lab investigation reports:	
Preventive maintenance records:	
Safety:	
Other Quality Assurance Issues:	
Technical supervisor:	Date:
Q.A. Staff :	Date:
Laboratory Director:	Date:



Appendix 8 - continued

**Illinois Department of Public Health – Division of Laboratories  
Quality Assessment Semi-Annual Managerial Review**

Performed by: \_\_\_\_\_ Date: \_\_\_\_\_ Test(s): \_\_\_\_\_

The technical supervisor or his/her designee must review the level of compliance in his/her area(s) of responsibility with the Division’s quality assurance policies and procedures semiannually. Indicate Y, N, or NA in the findings box. Use the comments/corrective action space to documented the proposed corrective action, where appropriate.

<b>ASSESSMENT REQUIREMENTS</b>	<b>Finding</b>	<b>Comments/ corrective action</b>
<b>FACILITY</b>		
Work area arranged to minimize problems in specimen handling, examination and testing of specimens, and reporting of test results		
Workbench space is sufficient for test performance, is well lit, and has water, gas, suction, and electrical outlets as necessary		
Instruments, equipment, and computer systems are placed in locations where their operation is not affected adversely by physical or chemical factors such as heat, direct sunlight, vibrations, power fluctuations, or fumes from acid or alkaline solutions		
Equipment tops are not used as workbench space		
Stable electrical source is maintained, e.g. outlets, not extension cords, and meets the power requirements for each piece of equipment		
Follows contamination prevention practices to minimize contamination of patient specimens, equipment, instruments, reagents, materials, and supplies		
Performs wipe test of areas where radioactive material or amplification procedures are used in order to monitor and prevent contamination		
Processing of mycobacteriology cultures is performed in a manner that prevents contamination of the environment		
Molecular amplification procedures have a mechanism to detect cross contamination of patient specimens		
Molecular amplification procedures have a uni-directional workflow – separate areas for reagent preparation, pre-amplification, and post-amplification		
Has equipment and/or instruments capable of producing results within the stated test performance specifications		
Has test systems, equipment and/or instruments		



<b>ASSESSMENT REQUIREMENTS</b>	<b>Finding</b>	<b>Comments/ corrective action</b>
necessary to perform the laboratory's volume of testing within established turnaround times		
Data capacity in the laboratory information system is sufficient for current data entry and reporting		
Safety procedures are established, accessible, and observed		
Has clean up spill kits (chemical, biological, radiological)		
Has determine the amount of waste that can be safely contained and precautions are taken to ensure that liquid waste does not spill or splash while in travel status		
Maintains records in a secure area		
Records are stored according to the established schedule		
Maintains copies of the original test requisition or electronic equivalents		
Retains copies of all reports including original, preliminary, corrected, and final reports		
<b>GENERAL LABORATORY SYSTEMS – CONFIDENTIALITY</b>		
Controls visitor access to the laboratory areas		
Has safeguards to ensure confidentiality of patient information and test reports		
<b>GENERAL LABORATORY SYSTEMS – IDENTIFICATION &amp; INTEGRITY</b>		
Ensures positive specimen identification from specimen receiving to the reporting of results		
Maintains optimum integrity of patient's specimen, follows instructions for performance of each test method and analyzes the specimen within the limitations of the test methodology		
<b>GENERAL LABORATORY SYSTEMS – COMPLAINT INVESTIGATION and COMMUNICATION</b>		
Documents all complaints and problems reported to the laboratory		
Investigates all complaints and implement corrective action when applicable		
<b>GENERAL LABORATORY SYSTEMS – PERSONNEL ASSESSMENT</b>		
Monitors each individual's competency and identify remedial training or continuing educational needs		
<b>GENERAL LABORATORY SYSTEMS – PT</b>		
Reviews and evaluates laboratory's PT results		
Reviews its menu to determine if it tests for any		

<b>ASSESSMENT REQUIREMENTS</b>	<b>Finding</b>	<b>Comments/ corrective action</b>
analyte for which there is no PT		
Twice annually verifies the accuracy of the test without PT		
Documents review of PT score and corrective action taken		
<b>PREANALYTIC SYSTEM</b>		
Retains all laboratory test requests		
Documents attempts to collect written lab orders following a verbal request		
Uniquely identifies patient specimens		
Ensures that individuals who entered data including clerical staff correctly match patient information		
Provides written instructions or electronic equivalents to submitters to ensure that patient preparation requirements have been followed		
Specimens are properly stored		
Follows referral laboratory's instructions, as appropriate, for transport specimens		
Notifies submitter when specimen meets its unsatisfactory criteria and it is unsuitable for testing		
Has a current service manual for each reference laboratory		
Documents the date and time it receives specimens		
Maintains copy of CLIA certificate of reference laboratory		
<b>ANALYTIC SYSTEM</b>		
Has current and approved SOP's		
SOP includes calibration and calibration verification procedures		
SOP includes quality control procedures and corrective action		
Laboratory information system SOP are available to operators		
Follows manufacturer's instructions for the use of equipment, instruments, reagents, materials and supplies		
Assesses water quality (may include pH, silicate content, particular matter, bacterial and organic content)		
Monitors and documents results for acceptable temperature range on temperature controlled spaces, equipment, and instruments		
Documents dates for expiration of kits/ reagents and date opened		
Uses reagents, solutions, control materials, within their expiration date, free of contamination, or other		

ASSESSMENT REQUIREMENTS	Finding	Comments/ corrective action
signs of deterioration		
Uses components of reagents kits with the same lot number unless otherwise approved by the manufacturer/supplier		
Verifies or establishes performance specifications for any new test/ major change to the procedure (SOP DAA005)		
Verifies or establishes performance specifications for each instrument when multiple instruments are used		
Performs maintenance and function checks as defined in the preventive maintenance manual		
Maintains instrument / equipment maintenance service records		
Follows and documents the necessary function checks as stated by the laboratory information system for the computer and devices such as monitors, printers and modems		
For instruments that automatically perform function checks and flag problems, the laboratory documents the corrective actions in response to the flagged problem		
Fluorescent light source has not exceeded the manufacturer's established optimal timeframe		
Autodiluters, microdiluters and/or pipettors are checked for adequate and consistent delivery		
For systems that perform simultaneous fluid delivery to multi well plates or tubes, the laboratory checks for uniform deliver of reagents or washing solutions to all wells or tubes		
The laboratory monitors the accuracy and precision of each phase of the analytical testing process by using control procedures		
Control procedures to the test system includes checking for reagent contamination or deterioration, reagent lot variation, reaction temperature fluctuation, inadequate sampling, improper loss of calibration, electronic or mechanical failure, power supply variances		
Controls procedures that affect the test environment include checking for temperature, airflow, light intensity, humidity		
Testing personnel are trained prior to testing on the test performed (SOP)		
Uses control samples, at a minimum, as frequent as specified by the manufacturer		
Each quantitative procedure include 2 controls of different concentration		

<b>ASSESSMENT REQUIREMENTS</b>	<b>Finding</b>	<b>Comments/ corrective action</b>
Each qualitative procedure includes a negative and positive control		
Each procedure producing graded or titered results include a negative control and a control with graded or titered reactivity		
Verifies acceptable ranges for control materials		
Media are checked for sterility, ability to support growth		
Maintains QC documentation from manufacturer and documents receipt and condition of each batch, lot, or shipment		
Uses ATCC controls or have established reactivity for each organism		
Investigates QC failures and document all corrective action taken		
<b>POSTANALYTIC SYSTEM</b>		
Test reports indicate the location where the test was performed		
Test report dates are not changed		
Test report corrected copies leave an audit trail		
Test results are released to authorized persons		
Laboratory documents the date, time test results, and person's name to whom test results were given verbally to alert of panic values		
Laboratory maintains an "exact duplicate" test report or electronic equivalent		
<b>PERSONNEL</b>		
A current CLIA file is maintained for each testing staff member and supervisor.		
Personnel assessments are performed for each testing staff member for each test performed		
Monitors each individual's competency and identifies remedial training or continuing educational needs		

# **CHEERS QAPP 3**

## **Appendix 22: UIH Procedures for Archiving Cultures**



*University of Illinois Medical Center at Chicago*  
*Pathology Laboratories*  
*Clinical Microbiology Laboratory*

**PRINCIPLE:**

Long term storage of isolates may be achieved by freezing in a storage medium at -70°C. Isolates may be obtained from commercial sources (i.e. ATCC) or prepared from in-house isolates. The storage medium used is Remel Pras Milk (skim milk) which is dispensed into 2 ml cryovials. The cryobox used for freezing the cryovials contains 81 positions. The cryobox is given the name of the type of organisms to be stored (i.e. ATCC strains) and a sequential number. Information about the organisms stored in each of the 81 cryobox positions is written on the cryobox logsheet. There are two type of logsheets used, one for VRE isolates (Appendix A), and the other is for all other isolates (Appendix B). The data or pedigree of particular isolate is maintained in a data binder by including the Sunquest worksheet.

**SPECIMEN:**

Pure culture from overnight growth on an appropriate medium

**EQUIPMENT AND MATERIALS:**

**Equipment:**

-70° C Freezer  
35 – 37°C Incubator (ambient or CO<sub>2</sub> as appropriate)

**Materials:**

Sterile 2ml Cryovial  
Plastic Cryobox  
Sterile loop  
Sterile swab  
Sterile applicator stick  
Appropriate culture media

**PROCEDURE - STEPWISE:**

**Freezing of Stock Strains**

1. Obtain the binder of the organism type to freeze (i.e. ATCC strains, VRE strains, etc). On the cryobox logsheet locate a vacant location. Write the name of the organism on the logsheet. Include the ATCC number and/or Sunquest accession number where appropriate. Note the location to be used.
2. Label cryovial with organism name and location in cryobox, i.e. *S. aureus* Box 1 #23.

***University of Illinois Medical Center at Chicago  
Pathology Laboratories  
Clinical Microbiology Laboratory***

3. Using a sterile disposable pipet, dispense approximately 2 ml of Remel Pras milk into cryovial.
3. Using a sterile swab or loop, suspend a heavy inoculum into the vial and cap tightly.
4. Label the Sunquest workup printout with the cryovial box used and location. Insert sheet into binder in numerical order.
5. Place vial in proper cryobox location in the -70° C freezer located in Room 241.

**Retrieval of Frozen Stock Strains**

1. Locate required isolate in stock culture binders
2. Retrieve cryobox from -70° C freezer located in Room 241.
3. Remove cryovial from cryobox. Slightly warm vial so the top portion of skin milk may be removed using a sterile applicator stick or loop. **DO NOT COMPLETELY THAW VIAL.**
4. Subculture to appropriate culture media.

**REFERENCES:**

Isenberg, Henry D, et al. 2006. *Clinical Microbiology Procedures Handbook*, 2<sup>nd</sup> ed. American Society for Microbiology, Washington, D.C.



*University of Illinois Medical Center at Chicago*  
*Pathology Laboratories*  
*Clinical Microbiology Laboratory*

**Appendix A**

	Patient Name	Med. Rec. No.	Acc. No.	Date of culture	Isolate	Linezolid Results					Tech	MIC Results: S, I, or R.						
						Date of Test	AST method (KBS or E-test)	Lot #	MIC or Zone size	Inter (S,I,R)		Vanc	Amp	Syne	Chlor	Eryth	Rif	Tetra
1.																		
2.																		
3.																		
4.																		
5.																		
6.																		
7.																		
8.																		
9.																		
10.																		
11.																		
12.																		

*University of Illinois Medical Center at Chicago  
 Pathology Laboratories  
 Clinical Microbiology Laboratory*

	Patient Name	Med. Rec. No.	Acc. No.	Date of culture	Isolate	Linezolid Results					Tech	MIC Results: S, I, or R.						
						Date of Test	AST method (KBS or E-test)	Lot #	MIC or Zone size	Inter (S,I,R)		Vanc	Amp	Syne	Chlor	Eryth	Rif	Tetra
13.																		
14.																		
15.																		
16.																		
17.																		
18.																		
19.																		
20.																		
21.																		
22.																		
23.																		
24.																		
25.																		

**University of Illinois Medical Center at Chicago**  
**Pathology Laboratories**  
**Clinical Microbiology Laboratory**

	Patient Name	Med. Rec. No.	Acc. No.	Date of culture	Isolate	Linezolid Results					Tech	MIC Results: S, I, or R.						
						Date of Test	AST method (KBS or E-test)	Lot #	MIC or Zone size	Inter (S,I,R)		Vanc	Amp	Syne	Chlor	Eryth	Rif	Tetra
26.																		
27.																		
28.																		
29.																		
30.																		
31.																		
32.																		
33.																		
34.																		
35.																		
36.																		
37.																		
38.																		

*University of Illinois Medical Center at Chicago  
 Pathology Laboratories  
 Clinical Microbiology Laboratory*

	Patient Name	Med. Rec. No.	Acc. No.	Date of culture	Isolate	Linezolid Results					Tech	MIC Results: S, I, or R.						
						Date of Test	AST method (KBS or E-test)	Lot #	MIC or Zone size	Inter (S,I,R)		Vanc	Amp	Syne	Chlor	Eryth	Rif	Tetra
39.																		
40.																		
41.																		
42.																		
43.																		
44.																		
45.																		
46.																		
47.																		
48.																		
49.																		
50.																		
51.																		

**University of Illinois Medical Center at Chicago**  
**Pathology Laboratories**  
**Clinical Microbiology Laboratory**

	Patient Name	Med. Rec. No.	Acc. No.	Date of culture	Isolate	Linezolid Results					Tech	MIC Results: S, I, or R.						
						Date of Test	AST method (KBS or E-test)	Lot #	MIC or Zone size	Inter (S,I,R)		Vanc	Amp	Syne	Chlor	Eryth	Rif	Tetra
52.																		
53.																		
54.																		
55.																		
56.																		
57.																		
58.																		
59.																		
60.																		
61.																		
62.																		
63.																		
64.																		

**University of Illinois Medical Center at Chicago**  
**Pathology Laboratories**  
**Clinical Microbiology Laboratory**

	Patient Name	Med. Rec. No.	Acc. No.	Date of culture	Isolate	Linezolid Results					Tech	MIC Results: S, I, or R.						
						Date of Test	AST method (KBS or E-test)	Lot #	MIC or Zone size	Inter (S,I,R)		Vanc	Amp	Syne	Chlor	Eryth	Rif	Tetra
65.																		
66.																		
67.																		
68.																		
69.																		
70.																		
71.																		
72.																		
73.																		
74.																		
75.																		
76.																		
77.																		

*University of Illinois Medical Center at Chicago  
 Pathology Laboratories  
 Clinical Microbiology Laboratory*

	Patient Name	Med. Rec. No.	Acc. No.	Date of culture	Isolate	Linezolid Results					Tech	MIC Results: S, I, or R.					
						Date of Test	AST method (KBS or E-test)	Lot #	MIC or Zone size	Inter (S,I,R)		Vanc	Amp	Syne	Chlor	Eryth	Rif
78.																	
79.																	
80.																	
81.																	

*University of Illinois Medical Center at Chicago*  
*Pathology Laboratories*  
*Clinical Microbiology Laboratory*

**Appendix B**

CRYO BOX NUMBER _____		
1	28	55
2	29	56
3	30	57
4	31	58
5	32	59
6	33	60
7	34	61
8	35	62
9	36	63
10	37	64
11	38	65
12	39	66
13	40	67
14	41	68
15	42	69
16	43	70
17	44	71
18	45	72
19	46	73
20	47	74
21	48	75
22	49	76
23	50	77
24	51	78
25	52	79
26	53	80
27	54	81



# **CHEERS QAPP 3**

## **Appendix 23: IDPH Procedures for Archiving Cultures for PCR**

## **IDPH Protocol for archiving stool specimens for later extraction of nucleic acids and viral identification by PCR**

As part of the Norovirus identification procedure, stool specimens are prepared for RNA extraction by adding 0.5 mL of buffer to a small amount of stool and 10 glass beads in a 1.5 mL microfuge tube. After vortexing to disrupt the stool matrix, the suspension is clarified by centrifugation. One-third of the supernatant is used to prepare RNA, and the remaining supernatant (over the disrupted stool and glass beads) is frozen at -70° C for long-term storage (archiving).

Note: Bacterial cultures are set up from the raw stool when it is received in the lab, but raw stool is not frozen/archived. Consequently, in the future, only viral identification (including other molecular manipulations – e.g., sequencing or cloning) would be possible from the archived material. We have been able to successfully amplify Norovirus RNA from supernatants that have been frozen for several years.

# **CHEERS QAPP 3**

## **Appendix 24: Unusual Occurrence Log**



**CHEERS: THE CHICAGO HEALTH,  
ENVIRONMENTAL EXPOSURE, AND  
RECREATION STUDY**

**STATISTICAL ANALYSES**

Project Statistician: Li Liu, PhD  
Division of Epidemiology and Biostatistics  
University of Illinois at Chicago  
School of Public Health

## 1. Power/sample size calculation

1.1. The sample size calculations and data analyses are based upon the two primary aims of this research study, namely, 1) to determine rates of acute gastrointestinal and non-gastrointestinal illness attributable to recreation on the CAWs, and 2) to define the relationship between concentrations of microbes and rates of illness among individuals with limited recreational water contact. As noted in the District's Expert Review Report (2006-038), should an epidemiologic study be conducted, it would require "sufficient statistical power to detect risks at levels deemed to be acceptable for regulatory purposes."

1.1.1. For Aim 1, we need to make sure that the number of participants is big enough in the study in order to detect with confidence, differences that may exist between the groups. The subtler the difference between groups (e.g., in rates of AGI), the larger the requisite sample size (e.g., the number of participants). Given that the background rate of AGI may be approximately 75 cases/1,000 people, detecting an excess risk in one group of 10/1,000 would mean differentiating rates of 75/1,000 in the "background rate" group, from a rate of 85/1,000 in an exposed group. Mathematical formulas allow the calculation of the required sample size for the comparison of rates between groups, and a given level of confidence desired in the conclusion that differences in rates are not due to chance alone.(Fleiss 1981) Using this formula, given an anticipated background rate of 75 cases of AGI/1,000 participants in the unexposed recreator group, in order to identify with confidence a rate of 97cases/1,000 in the CAWs group (a 22 cases/1,000 increase in rates), a sample size of 2,644 participants per group is required. Larger samples sizes would allow the detection of more subtle differences. Detecting an increase of 10 cases/1,000 exposures would require recruiting more than 40,000 participants, which would not be feasible.

1.1.2. For Aim 2, the calculation of the required number of study participants would be based on the development of a mathematical relationship

between concentrations of microbes in the water and rates of illness. With data obtained in such a study, it would be possible to model rates of illness as a function of water quality, allowing the prediction of rates of illness for a given concentration of microbes in the water. The sample size required for such a study can be calculated if one specifies 1) an estimated slope of the concentration-disease rate line, 2) an estimated background rate, and 3) the desired level of statistical confidence desired (Tosteson et al. 2003). Therefore, given that a 10-fold increase in microbe concentrations in freshwater increases the risk of AGI by approximately 60% among swimmers,(Wade et al. 2003) we will assume, for the purpose of sample size calculation, that the risk of illness among non-swimming recreators is one-fourth that of swimmers. In order to detect a 15% increase in risk of illness for a 10-fold increase in microbe concentrations, assuming a background rate of 75 cases of AGI/1,000, a sample size of 5,028 participants in the water-recreation groups (CAWs and general use waters) is required.

- 1.2. Given the above calculations for Aims 1 and 2, we will seek complete data on 2,644 subjects in each of the three groups or a final sample size of 7,932. Assuming a projected attrition rate of 15% (those who do not complete follow-up), a total of 9,330 participants will be recruited in order to obtain a final dataset for analysis with records of 7,932 individuals.

## 2. Health outcomes, Non-water related and Water Quality Measures

Potential outcome variables, effect modifiers and non-water related confounders, as well as water exposure and water-quality related predictors are presented in the tables at the end of this section.

Health outcomes of interest include Acute GI illness and Non-GI illness such as ear, eyes, skin, and upper respiratory illness. GI symptoms include abdominal cramps or stomach ache, diarrhea, nausea, and vomiting. Three syndromic definitions (any two or more of the symptoms; Highly Credible Gastrointestinal Illness; or the definition used in the NEEAR study, as outlined in the QAPP 2: Survey Methods) will be explored. Two GI

illness outcome variables will be considered in modeling stage: 0/1 indicator of illness and an ordinal variable of number of symptom items presented. For non-GI illness, a 0/1 indicator for any non-GI illness, indicators for ear, eyes, skin, and respiratory illness, and an ordinal variable of number of illness presented will be used in logistic regression models.

In evaluation of the overall risk, potential non-water related confounders include participant demographics, recent exposures (animal, food, someone ill) prior to recreation, pre-existing health conditions (such as chronic gastrointestinal illness, asthma, diabetes), and post-recreation exposures. In assessing the relationship between water quality and health outcomes, potential behavioral predictors include type and duration of activity, get wet at all, food/water during or after activity, sanitary measures, and other activity-specific exposure measures. Water-quality related predictors include *E. coli*, enterococcus, and coliphage concentrations, concentrations of coliphage serotypes linked to human sources; recent combined sewer overflow events and rainfall conditions.

### 3. Data Analysis

3.1. After data is collected, descriptive statistics will be conducted. This will include:

- 3.1.1. Descriptive statistics of study participant demographics (age, gender, race, distance traveled, and socioeconomic characteristics). Demographic distributions for all participants, as well as distributions by study group, location site, and year of enrollment will be examined.
- 3.1.2. Descriptive statistics of participant pre-existing health conditions and pre- and post-exposures. Overall distributions as well as distributions by study group, location site, and year of enrollment will be examined.
- 3.1.3. Summary statistics of all potential behavioral predictors, including type and duration of activity, water exposure measures, sanitary conditions, and food/water intake during or after activity, etc.



- 3.1.4. Summary statistics of indicator organism concentration (*E. coli*, enterococci, coliphages and coliphage serotypes) in water, by location and year.
  - 3.1.5. A correlation matrix of concentrations of indicators and pathogens, measured in samples collected at the same location, at the same point in time.
  - 3.1.6. Rates of all illness, including acute GI illness and Non-GI illness such as ear, eyes, skin, and upper respiratory illness. For GI illness, distributions of the number of GI symptoms presented (abdominal cramps or stomach ache, diarrhea, nausea, and vomiting) will be examined. For Non-GI illness, number of illness presented will also be examined. All rates and distributions of the ordinal outcomes will be presented by study group, location, and year.
  - 3.1.7. Descriptive statistics of organisms identified in clinical specimens, by study group.
- 3.2. Formal statistical analysis for this data includes:
- 3.2.1. Crude tests of equality of rates among the three study groups for all acute GI and non-GI illnesses. For these overall tests, chi-square test of homogeneity of proportions will be performed for all illness and symptoms of interest. Chi-square test for comparisons of proportions has the advantage of allowing for more than two groups. These tests are the first step in revealing whether the rates of illness are significantly different for the three study groups without considerations of other effect modifiers or confounders.
  - 3.2.2. Evaluation of the overall risk associated with the study groups. At this stage, the water-quality related measures are not included. For each illness of interest, logistic regression models will be used to estimate the study group effect on illness rate while adjusting for non-water related covariates such as participant demographics, pre-existing health conditions, pre- and post-activity exposures.

Interactions between covariates and study groups will also be examined. Model selections will be performed for all logistic models. Once a final model is selected for an outcome of interest, adjusted odds ratios for each group from the logistic regression model can be obtained by holding covariates constant at reasonable values. For ordinal outcomes of number of GI symptoms presented and number of Non-GI illness presented, proportional odds models in logistic regression will be applied, and common odds ratios will be reported. In fitting the logistic models for ordinal outcomes, the proportional odds assumption can be examined by the Score test in SAS.

- 3.2.3. Modeling the relationship between water quality and health outcomes. Since water-quality measures are often approximately log-normally distributed (El-Shaarawi 1989; El-Shaarawi and Viveros 1997; Noble et al. 2003), base 10 log ( $\log_{10}$ ) transformation of the count is likely to be done for all organism densities. Different types of water quality measures will be explored as predictor of the health outcomes. At participant level, since the time of entering and exit of water will be recorded, water qualities measured after (or close to) entering time and before (or close to) the exit time can be averaged to obtain measures that are subject specific. At access site level, average of measures specific to the activity location can be obtained. And overall daily water quality, such as the average of all measures of the day, and one-time down-stream measure, can be used as well. In the modeling stage, water-related covariates including behavioral factors, activity-specific exposure measures, and water quality indicators will be added into the logistic regression models. A model with nested interaction terms between water exposures and water quality measures will be included. These nested interaction models effectively assign zero exposure values by the use of indicators for

water-related activities and water exposures. For instance, in modeling the probability of illness  $p$ , the covariates of interest are:  $X_1 = 1$  if participant engaged in water-related activities, 0 otherwise;  $X_2 = 1$  if participant got wet during the activity; and  $X_3$  is the water organism density measure. The nested interaction model is parameterized as follows:

$$\log\left(\frac{P}{1-p}\right) = \beta_0 + \beta_1 X_1 + \beta_2 X_2 + \beta_3 X_1 X_3 + \beta_4 X_2 X_3 + \beta_5 X_1 X_2 X_3$$

Model selections will be done, and adjusted odds ratios for unit increase in indicator organisms will be reported to reflect the effect of water quality on illness.

#### **4.0 Overview of analyses to be performed using final datasets**

Prior to reaching conclusions from CHEERS regarding rates of illness, risk factors for illness, and causes of illness, numerous data analyses will be performed. These include:

##### 4.1 Water data: quality monitoring

###### 4.1.1 Quality monitoring: indicator microbes

4.1.1.1 *E. coli*: splits, blanks, recoveries (multi-level and single-level spiking)

4.1.1.2 Enterococci: splits, blanks, recoveries (multi-level and single-level spiking)

4.1.1.3 EPA dilution/plate concentration requirements for *E. coli* and Enterococci

4.1.1.4 F+ coliphages: splits, blanks, recoveries (multi-level and single-level spiking)/method 1602 validation for surface waters

4.1.1.5 Somatic coliphages: splits, blanks, recoveries (multi-level and single-level spiking) /method 1602 validation for surface waters

###### 4.1.2 Quality monitoring: pathogens

4.1.2.1 *Giardia*: splits, blanks, recoveries (multi-level and single-level spiking)

4.1.2.2 *Cryptosporidium*: splits, blanks, recoveries (multi-level and single-level spiking)

##### 4.2 Quality monitoring: sampling strategy

###### 4.2.1 Analyses of spatial and temporal predictors of microbe concentration

4.2.1.1 Location (access point)

4.2.1.2 Cross-section

- 4.2.1.3 Upstream/downstream
  - 4.2.1.4 Date
  - 4.2.1.5 Time within day
  - 4.2.2 Holding time
  - 4.2.3 Sample temperature
- 4.3 Descriptive measures of water quality
- 4.3.1 Microbiology
    - 4.3.1.1 Concentrations of indicator microbes by location, overall and by year
      - 4.3.1.1.1 E. coli
      - 4.3.1.1.2 Enterococci
      - 4.3.1.1.3 F+ coliphages
      - 4.3.1.1.4 Somatic coliphages
    - 4.3.1.2 Concentrations of pathogens by location, overall and by year:
      - 4.3.1.2.1 Giardia
      - 4.3.1.2.2 Cryptosporidium
  - 4.3.2 Water chemistry, by location, by year
    - 4.3.2.1 pH
    - 4.3.2.2 temperature
    - 4.3.2.3 dissolved oxygen
    - 4.3.2.4 conductivity
    - 4.3.2.5 turbidity
- 4.4 Environmental observations, by location, by year
- 4.4.1 wave
  - 4.4.2 wake
  - 4.4.3 wind
  - 4.4.4 wildlife

## 4.5 Meteorology

### 4.5.1 By month, by year:

#### 4.5.1.1 air temperature

#### 4.5.1.2 precipitation

### 4.5.2 By time of day, by month: cloud cover

## 4.6 Analyses of water quality

### 4.6.1 correlations among indicators, with factor analysis

#### 4.6.1.1 Overall

#### 4.6.1.2 By location

#### 4.6.1.3 By group of locations

#### 4.6.1.4 GUW

##### 4.6.1.4.1 Overall

##### 4.6.1.4.2 Small lakes + lagoons

##### 4.6.1.4.3 Rivers

##### 4.6.1.4.4 Lake Michigan

#### 4.6.1.5 CAWS

##### 4.6.1.5.1 Overall

##### 4.6.1.5.2 Locations above WRPs vs. below

##### 4.6.1.5.3 Locations below WRPs overall

##### 4.6.1.5.4 Locations below WRPs, North vs. South

### 4.6.2 Correlations among indicators (with factors) and pathogens (*Giardia* and *Cryptosporidium*)

#### 4.6.2.1 Overall

#### 4.6.2.2 By location

#### 4.6.2.3 By group of locations

### 4.6.3 GUW

#### 4.6.3.1.1 Overall

#### 4.6.3.1.2 Small lakes + lagoons

#### 4.6.3.1.3 Rivers

#### 4.6.3.1.4 Lake Michigan

- 4.6.3.2 CAWS
  - 4.6.3.2.1 Overall
  - 4.6.3.2.2 Locations above WRPs vs. below
  - 4.6.3.2.3 Locations below WRPs overall
  - 4.6.3.2.4 Locations below WRPs, North vs. South
- 4.6.4 Correlations among indicators and water chemistry
  - 4.6.4.1 Overall
  - 4.6.4.2 By location
    - 4.6.4.2.1 By group of locations
- 4.6.5 GUW
  - 4.6.5.1.1 Overall
  - 4.6.5.1.2 Small lakes + lagoons
  - 4.6.5.1.3 Rivers
  - 4.6.5.1.4 Lake Michigan
  - 4.6.5.2 CAWS
    - 4.6.5.2.1 Overall
    - 4.6.5.2.2 Locations above WRPs vs. below
    - 4.6.5.2.3 Locations below WRPs overall
    - 4.6.5.2.4 Locations below WRPs, North vs. South
- 4.6.6 Correlations among indicators and environmental observations
  - 4.6.6.1 Overall
  - 4.6.6.2 By location
  - 4.6.6.3 By group of locations
  - 4.6.6.4 GUW
    - 4.6.6.4.1 Overall
    - 4.6.6.4.2 Small lakes + lagoons
    - 4.6.6.4.3 Rivers
    - 4.6.6.4.4 Lake Michigan

#### 4.6.6.5 CAWS

4.6.6.5.1 Overall

4.6.6.5.2 Locations above WRPs vs. below

4.6.6.5.3 Locations below WRPs overall

4.6.6.5.4 Locations below WRPs, North vs. South

#### 4.6.7 Effect of rainfall, overall and by location

##### 4.6.7.1 Rainfall ( $\geq 0.1$ inch, present vs absent) for indicators

4.6.7.1.1 on day of sampling

4.6.7.1.2 24 hours prior

4.6.7.1.3 48 hours prior

4.6.7.1.4 72 hours prior

##### 4.6.7.2 Rainfall ( $\geq 0.1$ inch, present vs absent) for pathogens

4.6.7.2.1 on day of sampling

4.6.7.2.2 24 hours prior

4.6.7.2.3 48 hours prior

4.6.7.2.4 72 hours prior

#### 4.6.8 Effect of rainfall, overall and by location

##### 4.6.8.1 Rainfall ( $\geq 0.5$ inch, present vs absent) for indicators

4.6.8.1.1 on day of sampling

4.6.8.1.2 24 hours prior

4.6.8.1.3 48 hours prior

4.6.8.1.4 72 hours prior

##### 4.6.8.2 Rainfall ( $\geq 0.5$ inch, present vs absent) for pathogens

4.6.8.2.1 on day of sampling

4.6.8.2.2 24 hours prior

4.6.8.2.3 48 hours prior

4.6.8.2.4 72 hours prior



4.6.8.3 CAWS locations only: effect of CSOs on day of sampling,  
24 hours prior, 48 hours prior, 72 hours prior on:

4.6.8.3.1 Indicators

4.6.8.3.2 Pathogens

#### 4.7 Effect of WRP

4.7.1 Concentrations above vs below WRP on same day: both plants,  
North Side, Calumet:

4.7.1.1 Indicators: *E. coli*, enterococci, F+ coliphage, somatic  
coliphage total and for each serotype; factors

4.7.1.2 Pathogens: *Giardia*, *Cryptosporidium*

4.7.1.3 Water chemistry parameters: pH, temperature, DO,  
conductivity, turbidity

#### 4.8 Participants

4.8.1 Total participant recruitment, by date by location by group

4.8.2 Summary of recruitment by location by group by study year

4.8.3 Participants recruitment: without telephone follow-up, by reason  
(no interview A, no interview B, disqualified by swimming)

4.8.4 Loss to telephone follow-up: overall, by group

4.8.5 Demographic, location, activity differences for those with vs. those  
without telephone follow-up

4.8.6 Demographics of study participants: participants in phone follow-  
up total, and by group: age (mean, median, SD; <5, 5-<10, 10-<20;  
20-<40; 40-<65; >=65), gender, race, ethnicity

4.8.7 Recreational activity, by group, by year

#### 4.9 Non-water-related risk factors for illness (potential confounders)

4.9.1 Underlying GI illness: total and by group

4.9.2 Underlying respiratory illness: total and by group

4.9.3 Contact with someone who is sick

4.9.4 Contact with animals

4.9.5 Recent ingestion of raw fish, undercooked meat, hamburger, salad

#### 4.10 Water exposure

4.10.1 Recreational activity by location, by group

4.10.2 Duration of recreational activity by activity by location

4.10.3 Recreational activity by age, gender, by group

4.10.4 Did you get wet at all? overall, by group

4.10.5 Did you get wet all? by activity by group

4.10.6 How wet did your feet/legs get: overall, by group

4.10.7 How wet did your feet/legs get by activity by group

4.10.8 How wet did your hands/arms get: overall, by group

4.10.9 How wet did your hands/arms get: by activity by group

4.10.10 How wet did your torso get: overall, by group

4.10.11 How wet did your torso get: by activity by group

4.10.12 How wet did your face/head get: overall, by group

4.10.13 How wet did your face/head get: by activity by group

4.10.14 How much water did you swallow: overall, by group

4.10.15 How much water did you swallow: by activity by group

4.10.16 Eating, drinking and hand washing during/after recreation

4.10.17 Last water contact prior to enrollment

4.10.18 Water contact since enrollment

4.10.19 Boaters:

4.10.19.1 Did you capsize?

4.10.19.2 Get wet at launch?

4.10.19.3 Launch from pier/dock/shore?

4.10.20 Fishers:

4.10.20.1 Catch fish?

4.10.20.2 Bait use?

4.10.20.3 From shore or boat?

4.10.20.4 From shore: use of hip boots/waders?

#### 4.11 Recreation, risk perception

4.11.1 Frequency of water recreation at CAWS, other sites

4.11.2 Distance traveled

4.11.3 Leichert scale risk perception

#### 4.12 Health measures

4.12.1 Frequency of symptoms at baseline: GI, respiratory, skin, eye, and AGI symptom complex definitions

4.12.2 Rates of onset of symptoms following recreation: Kaplan-Meier curves and survival rates: overall and by group:

4.12.2.1 for each symptom (GI, respiratory, skin, eye)

4.12.2.2 for symptom complexes (specific definitions of AGI)

#### 4.13 Clinical Microbiology

4.13.1 Frequency of specimen collection vs. frequency of symptoms

4.13.2 Results of stool cultures

4.13.2.1 overall

4.13.2.2 by group

#### 4.14 Predictors of health events (individual symptoms and symptom complexes)

4.14.1 Demographic variables

4.14.1.1 Age

4.14.1.2 Gender

4.14.1.3 Race/ethnicity

4.14.2 Temporal factors

4.14.2.1 Study year

4.14.2.2 Season

4.14.3 Non-water related risk factors

4.14.3.1 Dietary factors

4.14.3.2 Ill contacts

4.14.3.3 Animal contact

#### 4.14.4 General water exposure factors

- 4.14.4.1 Study group
- 4.14.4.2 Recreational activity
- 4.14.4.3 Duration of recreational activity
- 4.14.4.4 Self-reported water exposure variables during recreation
- 4.14.4.5 Water recreation prior to enrollment
- 4.14.4.6 Water recreation subsequent to enrollment
- 4.14.4.7 Eat/drink during recreation

#### 4.14.5 Specific exposure factors (CAWS and G UW groups only)

- 4.14.5.1 Did you get wet at all?
- 4.14.5.2 How wet did your feet/legs get?
- 4.14.5.3 How wet did your hands/arms get?
- 4.14.5.4 How wet did your torso get?
- 4.14.5.5 How wet did your face/head get?
- 4.14.5.6 How much water did you swallow?
- 4.14.5.7 Boaters: Capsize? Wet at launch? Launch from pier/dock/shore?
- 4.14.5.8 Fishers: Catch fish? Type of bait? Fish from shore or boat? Use hip boot/waders?

#### 4.14.6 Microbial measures of water quality

- 4.14.6.1 Indicator concentrations, principal component factors at launch:
  - 4.14.6.1.1 At time point closest to launch/start
  - 4.14.6.1.2 At time point closest to return/end
  - 4.14.6.1.3 Average concentration during period of water recreation
- 4.14.6.2 Pathogen concentrations at launch:
  - 4.14.6.2.1 At time point closest to launch/start
  - 4.14.6.2.2 At time point closest to return/end

- 4.14.6.2.3 Average concentration during period of water recreation
- 4.14.6.3 CAWS locations: Indicator concentrations, principal component factors at sites above vs. below WRP
  - 4.14.6.3.1 At time point closest to launch/start
  - 4.14.6.3.2 At time point closest to return/end
  - 4.14.6.3.3 Average concentration during period of water recreation
- 4.14.6.4 CAWS locations: pathogen concentrations, principal component factors at sites above vs. below WRP
  - 4.14.6.4.1 At time point closest to launch/start
  - 4.14.6.4.2 At time point closest to return/end
  - 4.14.6.4.3 Average concentration during period of water recreation
- 4.14.6.5 CAWS locations: indicator and pathogen concentrations at non-WRP locations upstream of recreation
- 4.14.7 Non-microbial measures of water quality
  - 4.14.7.1 Water chemistry
  - 4.14.7.2 Environmental observations
  - 4.14.7.3 Rain and CSO
- 4.14.8 Exploration of propensity scores
- 4.14.9 Modeled integrated microbial exposure
- 4.14.10 Spatial-temporal model of integrated exposure
- 4.14.11 Final model selection using predictors identified in steps 4.14.1-4.14.10.

## References

Fleiss J. 1981. Statistical Methods for Rates and Proportions. 2 ed. NY: John Wiley & Sons. Chapter 3.

Tosteson TD, Buzas JS, Demidenko E, Karagas M. 2003. Power and sample size calculations for generalized regression models with covariate measurement error. Stat Med 22(7): 1069-1082.

[http://www.ncbi.nlm.nih.gov/entrez/query.fcgi?cmd=Retrieve&db=PubMed&dopt=Citation&list\\_uids=12652554](http://www.ncbi.nlm.nih.gov/entrez/query.fcgi?cmd=Retrieve&db=PubMed&dopt=Citation&list_uids=12652554)

Wade TJ, Pai N, Eisenberg JN, Colford JM, Jr. 2003. Do U.S. Environmental Protection Agency water quality guidelines for recreational waters prevent gastrointestinal illness? A systematic review and meta-analysis. Environ Health Perspect 111(8): 1102-1109. [http://www.ncbi.nlm.nih.gov/entrez/query.fcgi?cmd=Retrieve&db=PubMed&dopt=Citation&list\\_uids=12826481](http://www.ncbi.nlm.nih.gov/entrez/query.fcgi?cmd=Retrieve&db=PubMed&dopt=Citation&list_uids=12826481).

El-Shaarawi A. 1989. Inferences about the mean from censored water data. Water Resources Res 24(4): 685-690

El-Shaarawi A, Viveros R. 1997. Inferences about the mean in log regression with environmental applications. Envirometrics 8: 569-582

Noble RT, Weisberg SB, Leecaster MK, McGee CD, Ritter K, Walker KO, et al. 2003. Comparison of beach bacterial water quality indicator measurement methods. Environ Monit Assess 81(1-3): 301-312.

[http://www.ncbi.nlm.nih.gov/entrez/query.fcgi?cmd=Retrieve&db=PubMed&dopt=Citation&list\\_uids=12620023](http://www.ncbi.nlm.nih.gov/entrez/query.fcgi?cmd=Retrieve&db=PubMed&dopt=Citation&list_uids=12620023)